

### Table of Contents

<b>Chapter 1. Summary</b>	<b>2</b>	<b>5.2 Key Performance Waveforms</b>	<b>12</b>
<b>1.1 General Description</b>	<b>2</b>	5.2.1 45W PD3.0 System Start-up Time & Hold-up Time	12
<b>1.2 Key Features</b>	<b>2</b>	5.2.2 Q1 /Q2 Main Switching Voltage MOSFET Stress on at	13
1.2.1 System Key Features	2	20V/ 2.25A Loading @264Vac	13
1.2.2 AP3108L Key Features	2	5.2.3 System Output Ripple & Noise with @ PCB End	13
1.2.3 APR346 Key Features	2	5.2.4 Dynamic load ----0A-3A 10mS 125mA/uS( PCB End)	17
1.2.4 CY2311_16L Key Features	2	5.2.5 Output Voltage Transition Time	19
<b>1.3 Applications</b>	<b>2</b>	5.2.6 Output Voltage Transition Time from High to Low	21
<b>1.4 Main Power Specifications (CV &amp; CC Mode)</b>	<b>2</b>	5.2.7 Thermal Testing	22
<b>1.5 Evaluation Board Picture</b>	<b>2</b>	<b>5.3 EMI (CE) Testing results (Two cases Earth Ground</b>	<b>23</b>
<b>Chapter 2. Power Supply Specification</b>	<b>3</b>	<b>connected or Not)</b>	<b>23</b>
<b>2.1 Specification and Test Results</b>	<b>3</b>	5.3.1 Test Condition 115Vac 20V/2.25A (Not connecting	23
<b>2.2 Compliance</b>	<b>3</b>	to Earth Ground) (L) & (N)	24
<b>Chapter 3. Schematic</b>	<b>4</b>	5.3.2 Test Condition 230Vac 20V/2.25A (Connect to Earth	24
<b>3.1 EV1 Board Schematic</b>	<b>4</b>	Ground) (L) & (N)	25
<b>3.2 Bill of Material (BOM)</b>	<b>4</b>	5.3.3 Test Condition 115Vac 20V/2.25A (Not connecting	25
<b>3.3 Transformer Design Specification</b>	<b>6</b>	to Earth Ground) (L) & (N)	26
<b>3.4 Schematics Description</b>	<b>7</b>	5.3.4 Test Condition 230Vac 20V/2.25A (Connect to Earth	26
3.4.1 AC Input Circuit & Differential Filter	7	Ground) (L) & (N)	26
3.4.2 AP3108L PWM Controller	7		
3.4.3 APR346 Synchronous Rectification (SR) MOSFET	7		
Driver	7		
3.4.4 CY2311_16L PD3.0+ Decoder & Protection on /off P	7		
MOSFET and Interface to Power Devices	7		
<b>Chapter 4. The Evaluation Board (EVB) Connections</b>	<b>8</b>		
<b>4.1 EVB PCB Layout</b>	<b>8</b>		
<b>4.2 Quick Start Guide Before Connection</b>	<b>8</b>		
<b>4.3 System Setup</b>	<b>9</b>		
4.3.1 Connection with E-Load	9		
4.3.2 Canyon – Quick Charge 4/4+ Test Kit	10		
4.3.3 Input & Output Wires Connection	10		
<b>Chapter 5. Testing the Evaluation Board</b>	<b>11</b>		
<b>5.1 Input &amp; Output Characteristics</b>	<b>11</b>		
5.1.1 Input Standby Power	11		
5.1.2 Input Power Efficiency at Different AC Line Input	11		
Voltage	11		
5.1.3 Average Efficiency at Different Loading ( @ PCB end)	12		



## Chapter 1. Summary

### 1.1 General Description

The 45W USB PD 3.0 Adaptor Evaluation Board EV1 is composed of three main parts, AP3108L offers the DCM/CCM PWM switching, APR346 is a Synchronous Rectification Controller, and the CY2311\_16L is USB 3.0 protocol decoder. Based on monitoring CC1 & CC2 signals, CY2311\_16L interprets desired voltage and current setting, and then feedback information to primary side AP3108L controller for providing well regulated voltage and current as well as related power protections.

### 1.2 Key Features

#### 1.2.1 System Key Features

- SSR Topology Implementation with an Opto-coupler for Accurate Step Voltage Controlling
- USB PD 3.0 Compliance
- Meet DOE 6 and CoC Tier 2 Efficiency Requirements
- <30mW No-Load Standby Power

#### 1.2.2 AP3108L Key Features

- Current Mode PWM Controller
- Frequency Shift function changes frequency per line loading
- Frequency fold back for high average efficiency
- Integration of High-Voltage Start-Up Circuit to enable low standby power
- Integration of 100V LDO, X-Cap discharge for minimal system BOM components
- Constant load output current during output short circuit
- Rich Protection Functions: , Precise Secondary Side OVP, UVP, OLP, BNO, FOCP, SSCP, External Programmable OTP

#### 1.2.3 APR346 Key Features

- Synchronous Rectification operating at DCM, CCM and QR mode for Flyback topology
- Eliminate Resonant Ringing Interference
- Fewest External Components used

#### 1.2.4 CY2311\_16L Key Features

- Type-C USB PD DFP (Downstream Facing Port)
- USB PD2.0, PD 3.0 Protocol Decoding
- 10-Bit ADCs for voltage and current monitoring
- Built in Shunt Regulator for Constant Voltage and Constant Current
- Programmable OVP/UVP/OCP/OTP
- Internal Discharge MOS
- Internal Vbus Load Switch Driver
- 3V- 30V Operation Voltage without External Regulator
- Package 16-Pin TSSOP
- USB PD IC Compliance Certified – TID #1060013, 12/18/2017 ([http://canyon-semi.com.tw/images/USB-IF\\_compliance\\_certification1211.pdf](http://canyon-semi.com.tw/images/USB-IF_compliance_certification1211.pdf))

### 1.3 Applications

- USB PD 3.0 Wall Adaptor
- USB PD 3.0 Car Charger

### 1.4 Main Power Specifications (CV & CC Mode)

Parameter	Value
Input Voltage	90Vac to 264Vac
Input standby power	< 30mW
Main Output Vo / Io	5V/3A, 9V/3A, 12V/3A, 15V/3A, 20V/2.25A
Efficiency	89%
Total Output Power	45W
Protections	OVP, UVP, OLP, BNO, FOCP, SSCP, OTP
XYZ Dimension	67 x 41 x 25mm
ROHS Compliance	Yes

### 1.5 Evaluation Board Picture



Figure 1: Top View



Figure 2: Bottom View

## Chapter 2. Power Supply Specification

### 2.1 Specification and Test Results

Parameter	Test conditions	Min	Nom	Max	Eff / DoE VI	Eff / Tier2	Test Summary
V <sub>acin</sub> Input Voltage		90 V <sub>rms</sub>	115/230	264 V <sub>rms</sub>			
F <sub>line</sub> Frequency		47 Hz	50/60	64 Hz			
I <sub>in</sub> Input Current				1.3 A <sub>rms</sub>			Pass
No load Pin	At 230Vac <sub>in</sub> /50Hz, @ 5V, Pin < 75mW			30mW			Pass, the test result is 24mW
5V/3A @115Vac/230Vac Average efficiency	Board end		5V/3A		81.39%	81.84%	Pass, average efficiency is 86.93%
5V/3A @115Vac/230Vac 10% efficiency	Board end		5V/0.3A			72.48%	Pass, efficiency is 82.04%
9V/3A @115Vac/230Vac Average efficiency	Board end		9V/3A		86.60%	87.30%	Pass, average efficiency is 89.37%
9V/3A @115Vac/230Vac 10% efficiency	Board end		9V/0.3A			76.62%	Pass, efficiency is 80.86%
12V/3A @115Vac/230Vac Average efficiency	Board end		12V/3A		87.4%	88.3%	Pass, average efficiency is 89.91%
12V/3A @115Vac/230Vac 10% efficiency	Board end		12V/0.3A			77.4%	Pass, efficiency is 82.72%
15V/3A @115Vac/230Vac 10% efficiency	Board end		15V/3A		87.7%	88.8%	Pass, average efficiency is 90.03%
15V/3A @115Vac/230Vac 10% efficiency	Board end		15V/0.3A			78.85%	Pass, efficiency is 83.78%
20V/2.25A @115Vac/230Vac 10% efficiency	Board end		20V/2.25A		87.7%	88.8%	Pass, average efficiency is 89.18%
20V/2.25A @115Vac/230Vac 10% efficiency	Board end		20V/0.225A			78.85%	Pass, efficiency is 80.48%

### 2.2 Compliance

Parameter	Test conditions	Low to High	High to Low	standard	Test Summary
Standby Power (mW)	5V Output / @230Vac	-	24mW	30mW	Pass
Output Voltage Transition time	5V/3A to 9V/3A	49ms	50ms	275mS <	Pass
Output Voltage Transition time	9V/3A to 12V/3A	41ms	39ms	275mS <	Pass
Output Voltage Transition time	12V/3A to 15V/3A	41ms	39ms	275mS <	Pass
Output Voltage Transition time	15V/3A to 20V/2.25A	65ms	76ms	275mS <	Pass
Output Voltage Transition time	5V/3A to 20V/2.25A	211ms	249ms	275mS <	Pass
Output Connector	USB Type C	-	-	-	
Temperature	90Vac, 15V / 3A	-	-	-	Pass
Dimensions (W / D/ H)	L67mm x 41mm x 25mm	-	-	-	
Safety	IEC/EN/UL 60950 Standard	-	-	-	
EMI Conduction	FCC/EN55022 Class B	-	-	-	Pass

### Chapter 3. Schematic

#### 3.1 EV1 Board Schematic

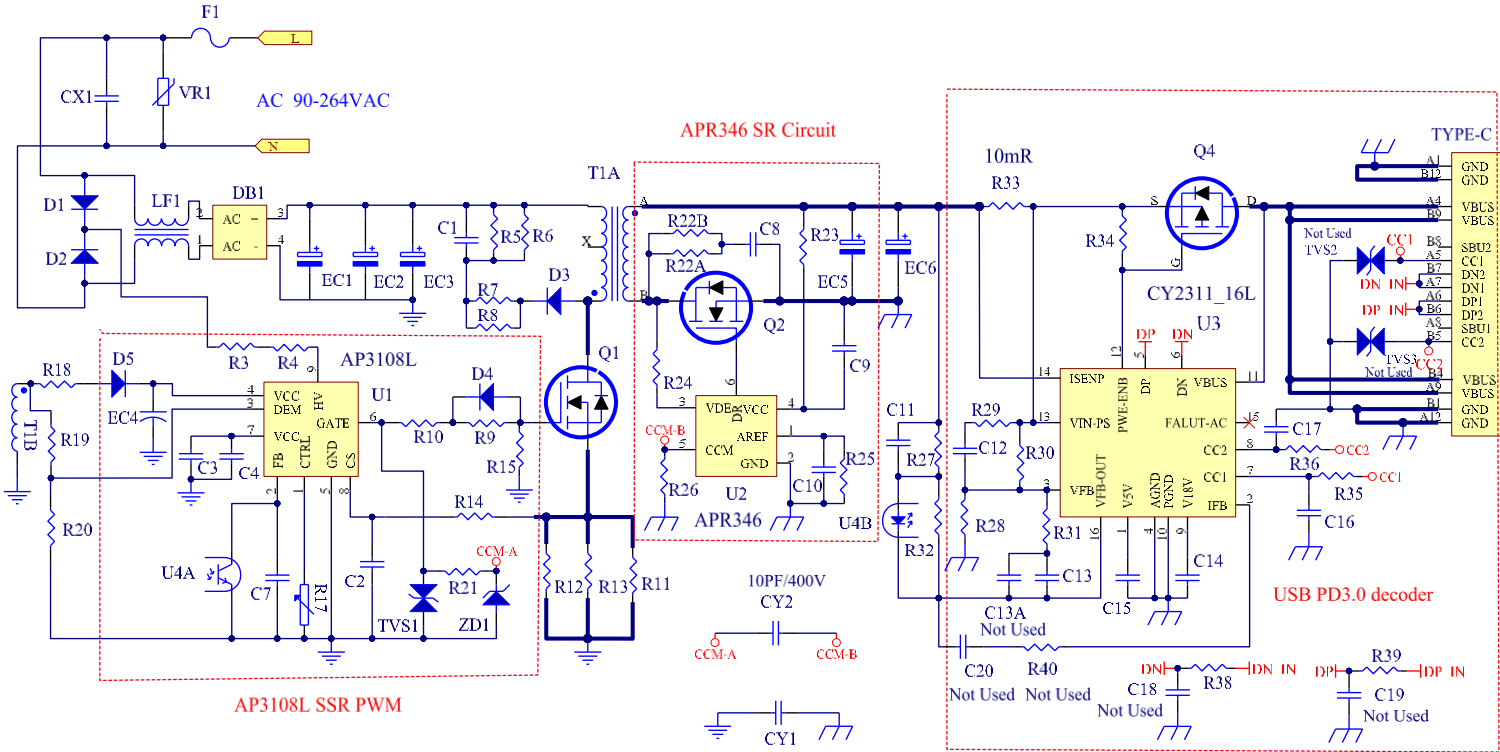

Figure 3: Evaluation Board Schematic

#### 3.2 Bill of Material (BOM)

Designator	Description	Manufactory	Footprint	Quantity
C1	1nF/1KV		C1206	1
C2	220pF/25V		C0603	1
C3, C4	4.7uF/50V		C0805	2
C7	1.2nF/50V		C0603	1
C8	2.2nF/200V		C0805	1
C9	100nF/50V		C0603	1
C10	15nF/25V		C0603	1
C11, C12	1nF/50V		C0603	2
C13	68nF/50V		C0603	1
C14	100nF/25V		C0603	1
C15	4.7uF/7.5V		C0805	1
C16, C17	220pF/25V		C0603	2
C13A	Not Used		C0603	
C20	Not Used		C0603	
C18,C19	Not Used		C0603	

CX1	330nF/275VAC, X-CAP			1
CY1	1nF/400V, Y-CAP		CY-10.0	1
CY2	10PF/400V, Y-CAP		CY-10.0	1
EC1	22UF/400V,E-CAP			1
EC2, EC3	27UF/400V,E-CAP			2
EC4	22uF/100V,E-CAP			1
EC5	680UF/25V,Solid Cap			1
EC6	680UF/25V, E-Cap			1
T1	T-RM10, Lp=760uH		RM10	1
VR1	Varistor, '561			1
F1	T3.15A/250V			1
J1	USB TYPE-C Connector		C-TYPE-C	1
LF1	Common Chock, Lp > 20mH			1
R3, R4	10K,1206		R1206	2
R5, R6	390K,1206		R1206	2
R7, R8	33R,1206		R1206	2
R9	82R		R0603	1
R10	10R		R0603	1
R11, R12, R13	1.0R		R1206	3
R14, R29	1K		R0603	2
R15	22K		R0603	1
R17	100K NTC		R0603	1
R18	2.2R		R0805	1
R19	270K		R0603	1
R20	20K		R0603	1
R21	2K		R1206	1
R22A, R22B	47R		R0805	2
R23, R24, R35, R36,R38,R39	20R		R0603	6
R25, R30	91K		R0603	2
R26	3K		R0603	1
R27	3K		R1206	1
R28	10K		R0603	1
R31, R32	4.7K		R0603	2
R33	Current sense resistor, 10mR		R1206	1
R34	47K		R0603	1
R40	Not Used		R0603	
<b>D1, D2, D5</b>	<b>S1MWF</b>	<b>DIODES</b>	<b>SOD-123</b>	<b>3</b>
<b>D3</b>	<b>S3MB</b>	<b>DIODES</b>	<b>SMB</b>	<b>1</b>
<b>D4</b>	<b>1N4148WS</b>	<b>DIODES</b>	<b>SOD-323</b>	<b>1</b>
<b>DB1</b>	<b>TT410</b>	<b>DIODES</b>	<b>MSBL</b>	<b>1</b>
<b>TVS1</b>	<b>DESD1LIN2WSQ</b>	<b>DIODES</b>	<b>SOD-323</b>	<b>1</b>

TVS2, TVS3	Optional		SOD-323	
U1	AP3108L	DIODES	SSOP-9	1
U2	APR346	DIODES	SOT23-6	1
U3	CY2311_16L	Canyon Semi	SSOP-16	1
ZD1	MMSZ5248B	DIODES	SOD-123	1
Q1	DMJ65H600SCTI	DIODES	TO-220	1
Q2	DMT10H010LPS-13	DIODES	POWERDI5060-8	1
Q4	DMP3007SCG	DIODES	DFN3*3	1
U4	Opto coupler, TCLT1006			1

### 3.3 Transformer Design Specification

RM10 (Ae=98mm <sup>2</sup> )						
NO	NAME	TERMINAL NO.		WINDING		
		START	FINISH	WIRE	TURNS	Layers
1	Np1	1 (Add Tube)	X	Φ 0.37*2	35	3
2	Na	10 (Add Tube)	3 (GND)	Φ 0.25*2	17	1
3	Shield1	3	NC	Φ 0.14*1	7	1
4	Ns1	A	B	Φ 0.8TIW *1 (Triple Insulated Wire)	7	1
5	Shield2	3	NC	Φ 0.14*1	30	1
6	Np2	X	12	Φ 0.37*2	11	1

Primary Inductance	Pin 1-12, all other windings open, measured at 20kHz, 0.4VRMS	760uH±5%
Primary Leakage Inductance	Pin 1-12, all other windings shorted, measured at 20kHz, 0.4VRMS	20 uH (Max.)
Note	1, Core connect to Pin3 2, Core: PC40	

### 3.4 Schematics Description

#### 3.4.1 AC Input Circuit & Differential Filter

There are three components in the section. The Fuse F1 protects against over-current conditions which occur when some main components failed. The LF1 & CX1 are common mode chock filter for the common mode noise suppression filtering because of the each coil with large impedance. The DB1 is rectifier, and basically converts alternating current & voltage into direct current & voltage.

#### 3.4.2 AP3108L PWM Controller

The AP3108L PWM controller U1 and Opto-Coupler U4 and Q1 are the power converting core components. Connected to filtered output after bridge circuit, R3 & R4 resistor path will provide start-up voltage and current during starting up through HV (Pin 9). Subsequent VCC power will be provided by voltage feedback from the auxiliary winding through R18-D5. This design is to accommodate with the required wide voltage range to support various protocols (including USB PD Programmable Power Supply PPS), from 5V to 20V.

Based on feedback of secondary side (Pin CATH of CY2311\_16L Decoder) to primary side (FB pin of AP3108L) through Opto-coupler U4, AP3108L will switch ON and Off Q1 to regulate desired voltage and current on the secondary side.

#### 3.4.3 APR346 Synchronous Rectification (SR) MOSFET Driver

The APR346 operates in CCM & DCM mode in this design under different load and drives the Q2 MOSFET based on the secondary side transformer on's duty cycle from its VET pin, but the turning off principle is different for DCM and CCM. At CCM mode: APR346 will turn off Q2 MOSFET when CCM pin voltage rises over threshold voltage VTH\_CCM. And CCM pin voltage was coupled by through Y-Cap from primary side turning on signal. Turning off principle for DCM: APR346 would turn off Q2 MOSFET when Drain-Source voltage rises over the turning off threshold voltage VTTHOFF.

As the power loss with the APR346-controlled MOSFET Q2 is less than Schottky Diodes, the total efficiency can be improved.

#### 3.4.4 CY2311\_16L PD3.0+ Decoder & Protection on /off P MOSFET and Interface to Power Devices

The few sets of important pins provide critical protocol decoding and regulation functions in CY2311\_16L:

- 1) **CC1 & CC2 (Pin 7, 8):** CC1 & CC2 (Configuration Channel 1 & 2) are defined by USB PD spec to provide the channel communication link between power source and sink devices.
- 2) **Constant Voltage (CV):** The CV is implemented by sensing VCC (pin 13) via resistor divider and comparing with internal reference voltage to generate a CV compensation signal on the CATH pin (pin 16). There is a loop compensation circuit C13 & R31 between Pin3 & Pin16, the fast voltage response can be obtained by adjusting their value. The output voltages can be adjusted by firmware programming.
- 3) **Over Current protection (OCP):** The OCP is implemented by sensing by current sense resistor (R33, 10mΩ) and current sense amplifier, then comparing with internal programmable reference voltage to generate a signal on CATH pin (pin 16).
- 4) **CATH (Pin 16):** It is the key interface link from secondary decoder (CY2311\_16L) to primary regulation circuit (AP3108L). It is connected to Opto-coupler U4A cath for feedback information based all sensed CC1 & CC2 voltage status for getting desired Vbus voltage & current.
- 5) **GATE Driver (Pin 12) to PMOSFET Gate:** The pin is used to turn on/off Vbus load switch (Q4) to enable/disable voltage output to the Vbus. An extra PMOSFET (Q4) is required to prevent reverse current from the attached battery source.

## Chapter 4. The Evaluation Board (EVB) Connections

### 4.1 EVB PCB Layout

The thickness for both sides of PCB board trace cooper is 1 Oz.

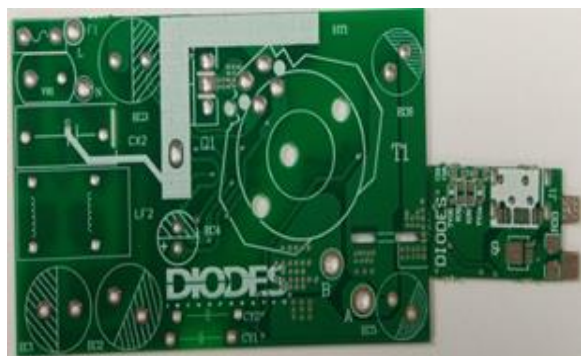

Figure 4: PCB Board Layout Top View

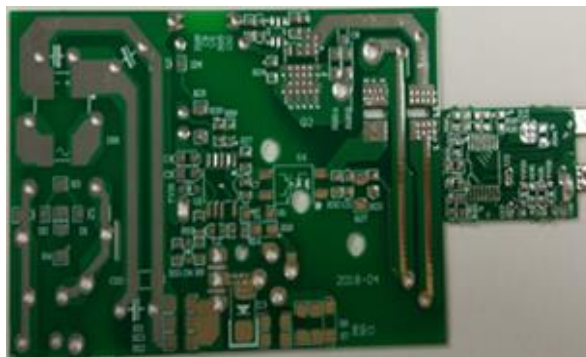

Figure 5: PCB Board Layout Bottom View

### 4.2 Quick Start Guide Before Connection

1) Before starting the 45W PD3.0 EVB test, the end user needs to prepare the following tool, software and manuals. For details, please contact Chongdiantou Website ([www.chongdiantou.com](http://www.chongdiantou.com)) for further information.

- Test Kit: POWER-Z KM001 ( Chongdiantou Website’s PD3.0 Test Kit)

POWER-Z KM001 Test Kit

Standard-A to Micro-B Cable

Type-C Cable



Figure 6: Items: Test Kit / Test Cables

- 2) Prepare a certified three-foot Type-C cable and a Standard-A to Micro-B Cable.
- 3) Connect the input AC L & N wires to AC power supply output “L and N “wires.
- 4) Ensure that the AC source is switched OFF or disconnected before the connection steps.





Figure 7: The Sample Board Input & Output Location

- 5) A type-C cable for the connection between EVB's and KM001's Type-C receptacles.
- 6) Use 2 banana jack cables, one part of the cables are connected to E-load + & - terminals while the other part of the cables are connected to EVB's VBUS & GND pads.
- 7) A Standard-A to Micro-B cable to be connected to the KM001's Micro-B receptacle & PC Standard-A receptacle respectively.

## 4.3 System Setup

### 4.3.1 Connection with E-Load

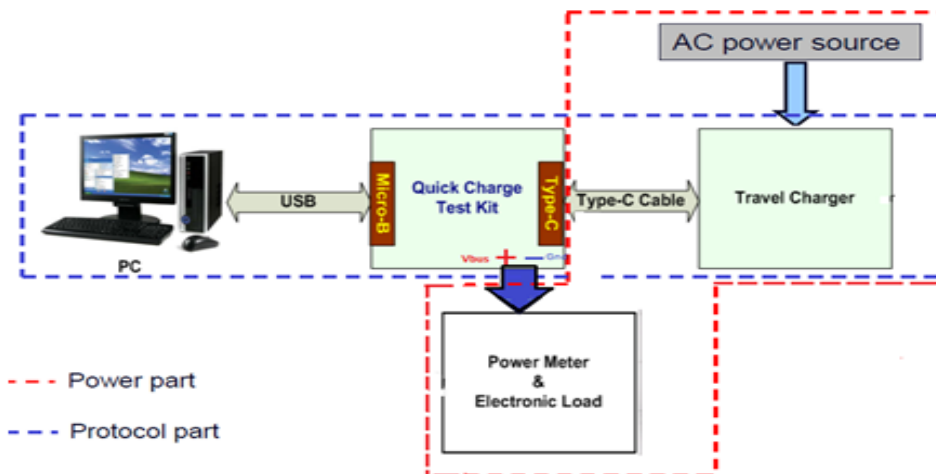
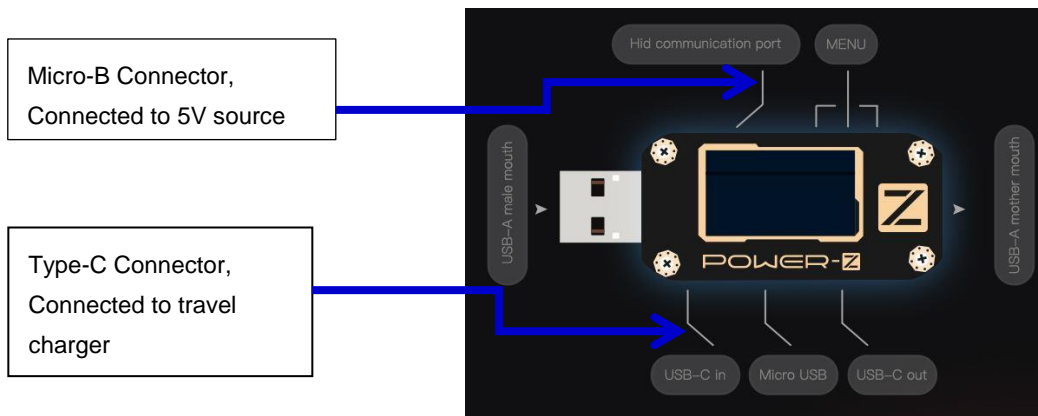

Figure 8: Diagram of Connections in the Sample Board

**4.3.2 Canyon – Quick Charge 4/4+ Test Kit**

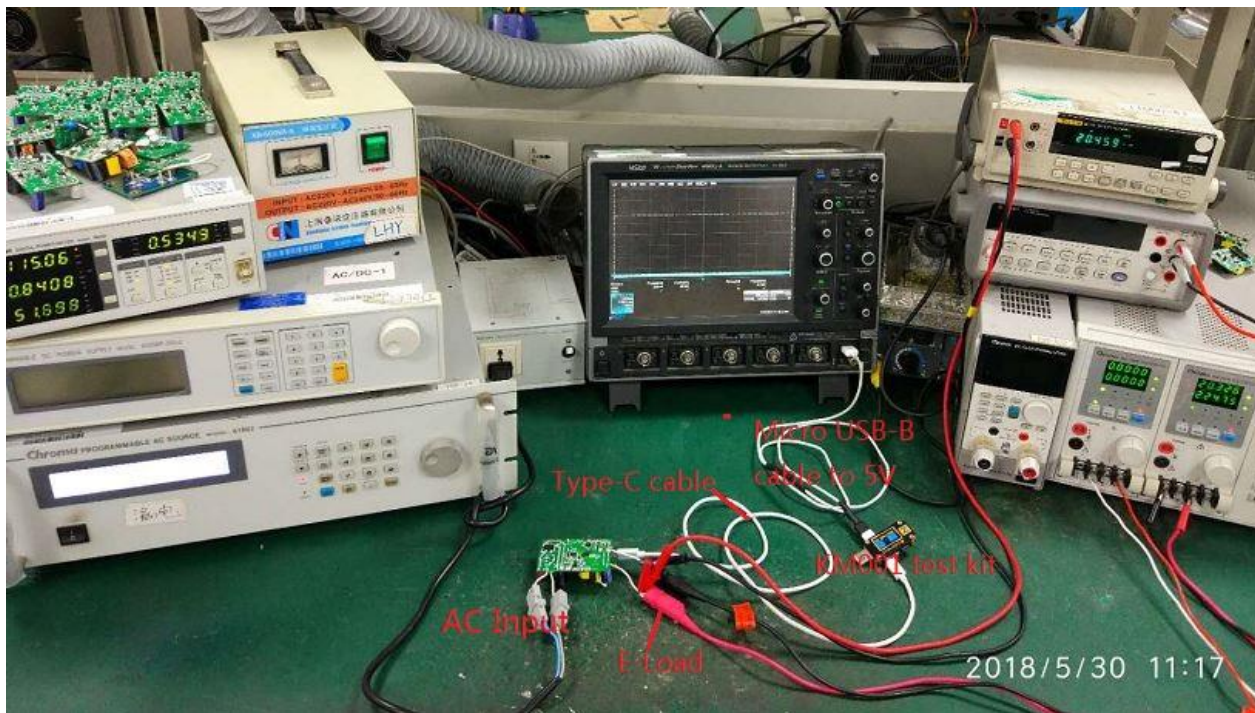

**Figure 9: The Test Kit Input & Output and E-load Connections**

For details, please look for chongdiantou website for POWER-Z KM001 User Guide.

<http://www.chongdiantou.com/wp/archives/13697.html>

**4.3.3 Input & Output Wires Connection**



**Figure 10: Wire Connection of 45W PD3.0 EVB to Test Kit and PC Computer**

## Chapter 5. Testing the Evaluation Board

### 5.1 Input & Output Characteristics

#### 5.1.1 Input Standby Power

Output Voltage	Input Voltage	Standby Power (mW)
@ 5V	115Vac 60Hz	18mW
	230Vac 50Hz	24mW

**Note:**

**Standard Power test condition: The output terminal of power board don't connected any load**

#### 5.1.2 Input Power Efficiency at Different AC Line Input Voltage

Vin (Vac)	Freq (HZ)	Vin (V)	Iin (A)	PF	Pin (W)	Vout (V)	Iout (A)	Pout (W)	Pd (W)	Eff (%)
90	47	89.99	0.988	0.593	52.23	20.465	2.249	46.03	6.204	88.12
115	60	115.1	0.828	0.529	51.03	20.468	2.249	46.03	4.997	90.21
230	50	230.34	0.562	0.389	50.35	20.47	2.249	46.04	4.313	91.43
264	63	264.22	0.492	0.388	50.46	20.466	2.249	46.03	4.432	91.22
90	47	89.99	1.002	0.584	52.53	15.335	2.997	45.96	6.571	87.49
115	60	115.1	0.853	0.521	51.13	15.336	2.997	45.96	5.168	89.89
230	50	230.35	0.563	0.387	50.35	15.34	2.997	45.97	4.376	91.31
264	63	264.33	0.487	0.388	49.98	15.34	2.997	45.97	4.006	91.98
90	47	90.02	0.815	0.573	42.03	12.256	2.997	36.73	5.299	87.39
115	60	115.12	0.715	0.501	41.2	12.258	2.997	36.74	4.463	89.17
230	50	230.35	0.465	0.373	39.98	12.256	2.997	36.73	3.249	91.87
264	63	264.32	0.4	0.381	40.31	12.256	2.997	36.73	3.579	91.12
90	47	90.04	0.641	0.545	31.5	9.172	2.997	27.49	4.012	87.27
115	60	115.14	0.588	0.461	31.26	9.172	2.997	27.49	3.772	87.94
230	50	230.37	0.354	0.37	30.24	9.172	2.997	27.49	2.752	90.90
264	63	264.33	0.305	0.375	30.23	9.172	2.997	27.49	2.742	90.93
90	47	90.08	0.403	0.495	17.96	5.07	2.997	15.19	2.765	84.60
115	60	115.17	0.361	0.429	17.86	5.071	2.997	15.20	2.662	85.09
230	50	230.4	0.205	0.361	17.06	5.07	2.997	15.19	1.865	89.07
264	63	264.33	0.181	0.358	17.10	5.07	2.997	15.19	1.905	88.86

### 5.1.3 Average Efficiency at Different Loading ( @ PCB end)

Vin	Vo	25% Load	50% Load	75% Load	100% Load	Average Efficiency	Energy Star Level VI	COC_Tier2	10% Load Efficiency
115V/60Hz	5V-3A	88.77%	89.44%	89.08%	88.2%	<b>88.87%</b>	>81.39%	>81.84%	82.54%
	9V -3A	90.22%	90.94%	90.68%	90.49%	<b>90.50%</b>	>86.62%	>87.30%	83.41%
	12V3A	90.48%	90.96%	90.79%	89.11%	<b>90.34%</b>	>87.40%	>88.30%	86.58%
	15V-3A	90.4%	90.96%	90.68%	89.87%	<b>90.48%</b>	>87.73%	>88.85%	86.41%
	20V-2.25A	88.8%	89.93%	89.99%	89.93%	<b>89.66%</b>	>87.73%	>88.85%	82.67%
230V/50Hz	5V-3A	85.03%	87.29%	88.08%	87.89%	<b>87.07%</b>	>81.39%	>81.84%	80.33%
	9V -3A	88.13%	90.38%	90.79%	90.72%	<b>90.01%</b>	>86.62%	>87.30%	80.04%
	12V3A	89.16%	90.95%	91.25%	91.02%	<b>90.59%</b>	>87.40%	>88.30%	84.38%
	15V-3A	89.47%	91.38%	91.36%	91.13%	<b>90.83%</b>	>87.73%	>88.85%	83.31%
	20V-2.25A	87.98%	90.79%	91.12%	91.09%	<b>90.25%</b>	>87.73%	>88.85%	79.95%

## 5.2 Key Performance Waveforms

### 5.2.1 45W PD3.0 System Start-up Time & Hold-up Time

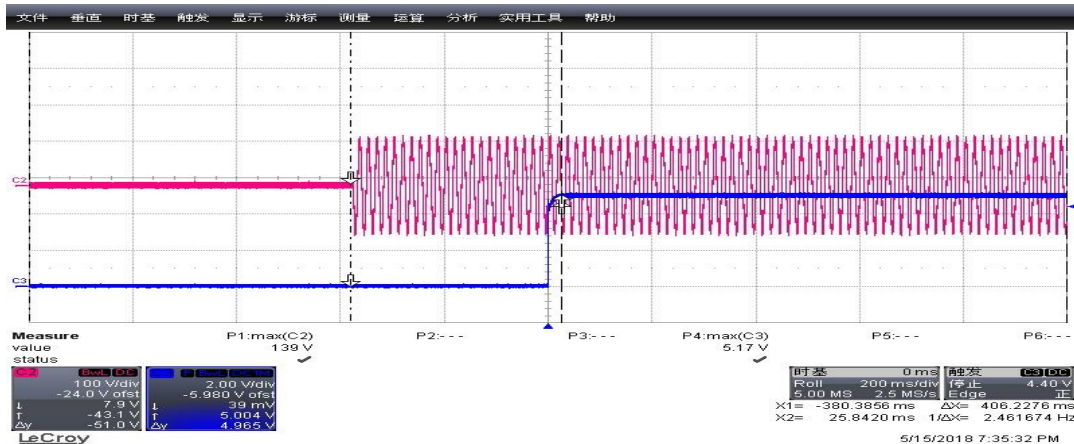

Figure 11: 45W PD 3.0 turn on time 0.406s 5V/3A at 90Vac

### 5.2.2 Q1 /Q2 Main Switching Voltage MOSFET Stress on at 20V/ 2.25A Loading @264Vac

**Primary side MOSFET - Q1**



**Figure 12: Q1 Vds Voltage stress**

**Secondary side SR MOSFET- Q2**

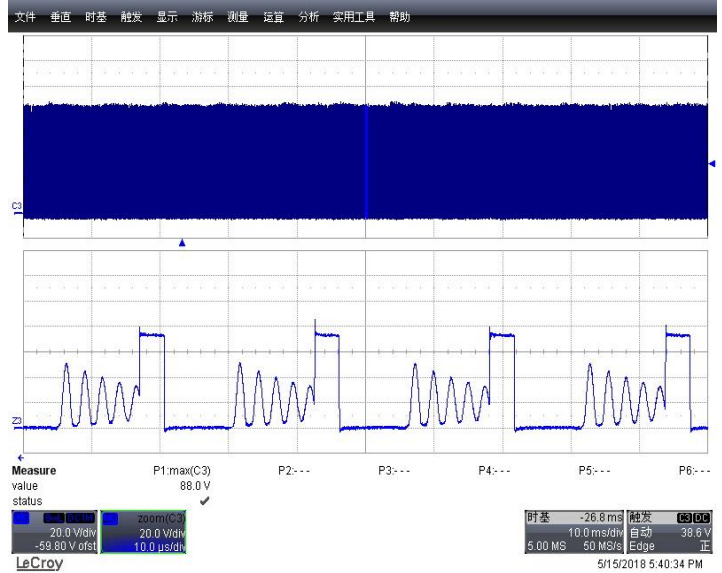

**Figure13: Q2 of Vds Voltage stress**

Vout	Vds(V)	Vds_Max_Spec	Ratio of voltage stress	Vout	VR (v)	VRM_Max_Spec	Ratio of voltage stress
20V	613V	650V	94%	20V	88V	100V	88%

### 5.2.3 System Output Ripple & Noise with @ PCB End

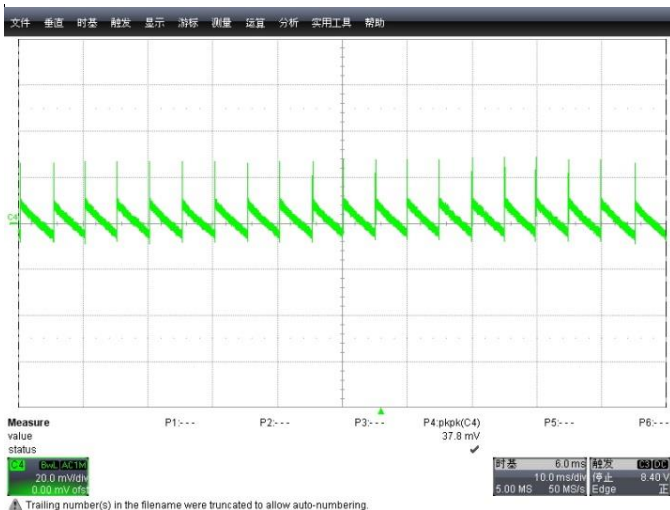

**Figure 14: The Ripple at 90Vac/60Hz  $\Delta V=27.8mV$  5V/0A**

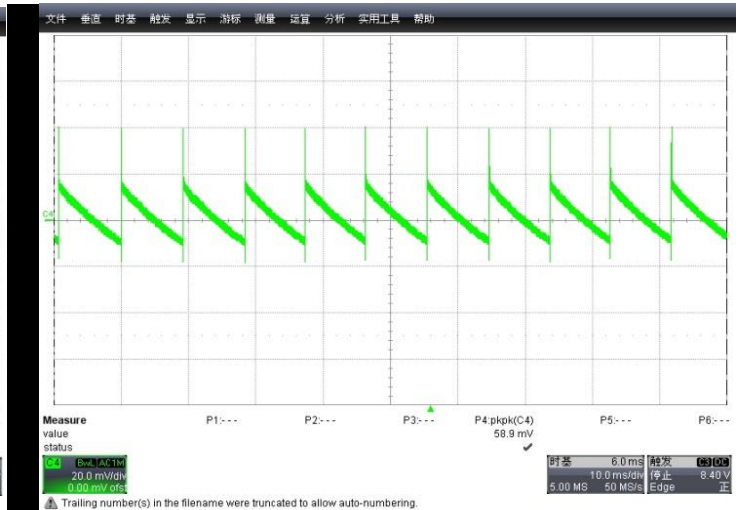

**Figure 15: The Ripple at 264Vac/50Hz  $\Delta V=58.8mV$  5V/0A**



Figure 16: 90Vac/60Hz 5V/3A  $\Delta V=96\text{mV}$

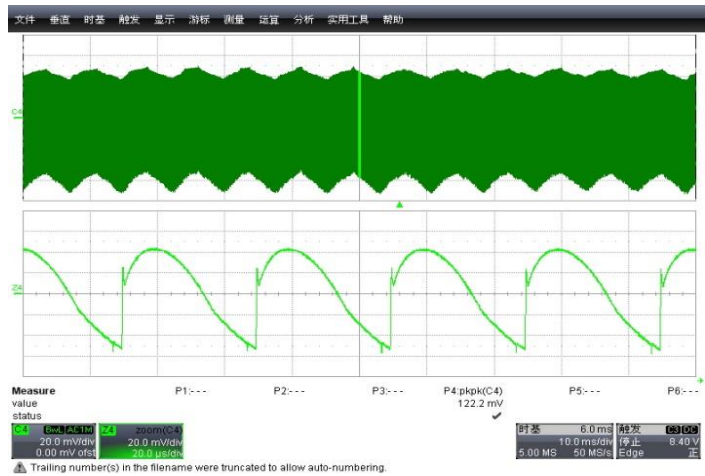

Figure 17: 264Vac/50Hz 5V/3A  $\Delta V=122\text{mV}$

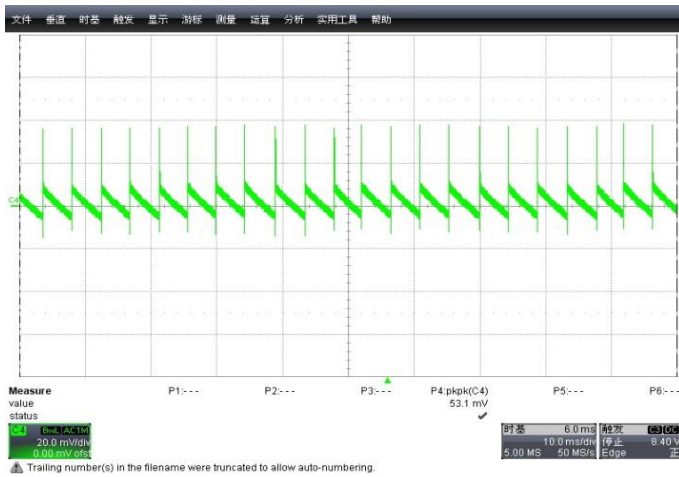

Figure 18: 90Vac/60Hz 9V/0A  $\Delta V=51.1\text{mV}$

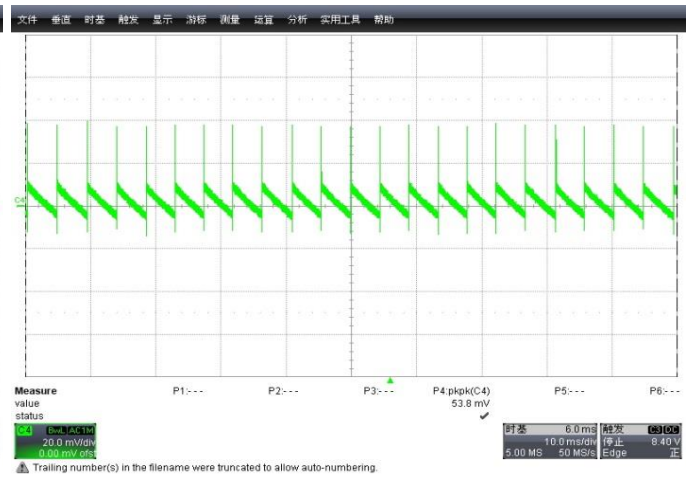

Figure 19: 264Vac/50Hz 9V/0A  $\Delta V=54\text{mV}$

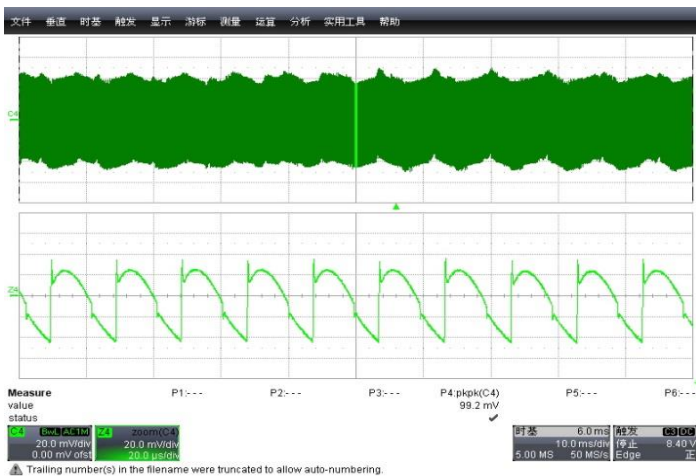

Figure 20: 90Vac/60Hz 9V/3A  $\Delta V=98\text{mV}$

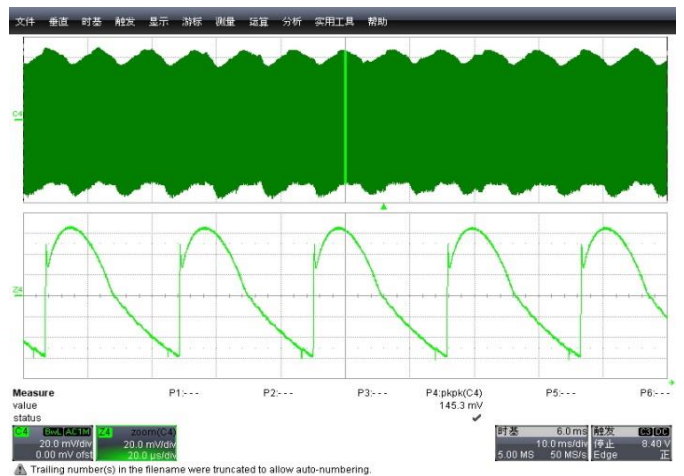

Figure 21: 264Vac / 60Hz 9V/3A  $\Delta V=145\text{mV}$

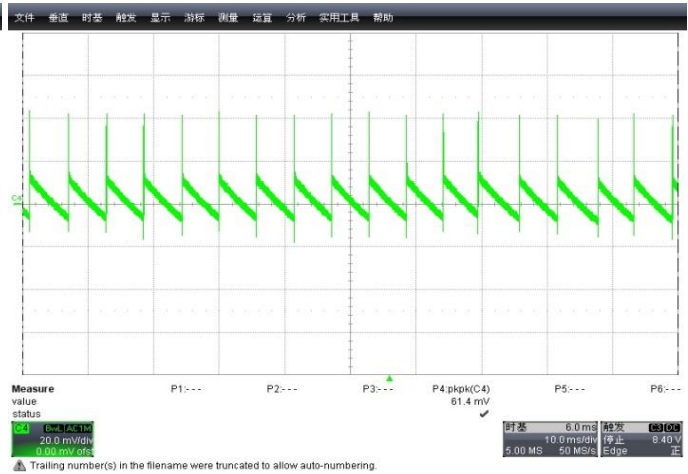
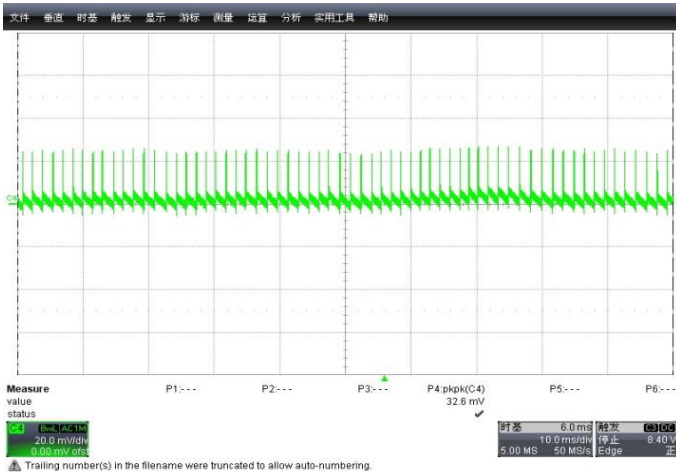

Figure 22: 90Vac/60Hz 12V/0A  $\Delta V=33\text{mV}$

Figure 23: 264Vac / 60Hz 12V/0A  $\Delta V=61\text{mV}$

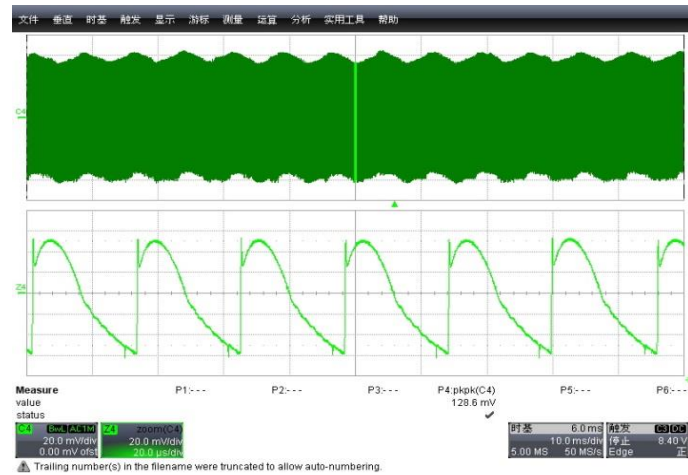
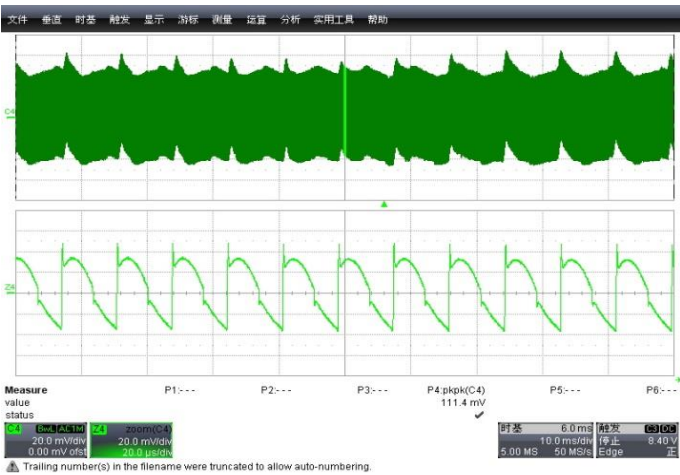

Figure 24: 90Vac/60Hz 12V/3A  $\Delta V=111\text{mV}$

Figure 25: 264Vac / 60Hz 12V/3A  $\Delta V=128\text{mV}$

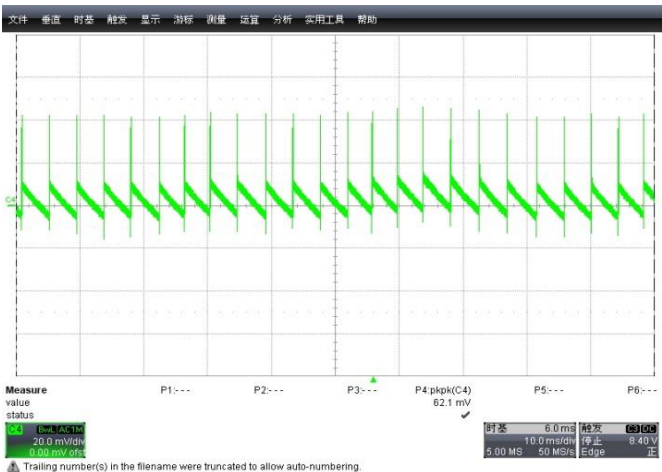
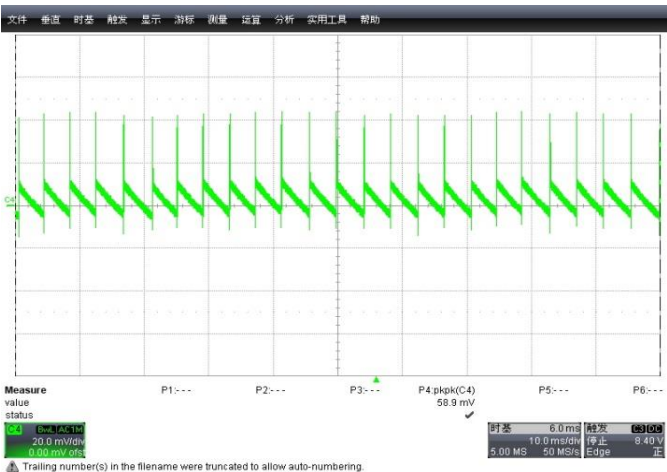
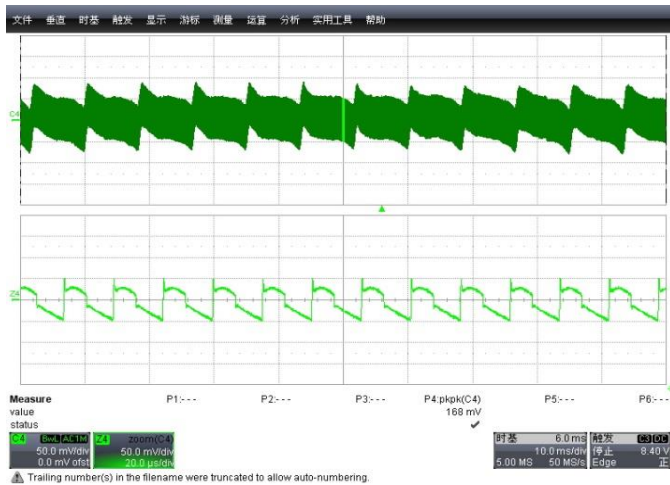
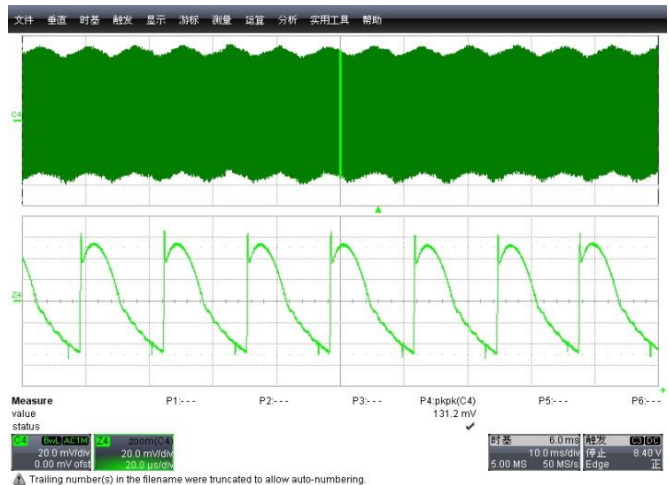

Figure 24: 90Vac/60Hz 15V/0A  $\Delta V=59\text{mV}$

Figure 25: 264Vac / 60Hz 15V/0A  $\Delta V=62\text{mV}$



**Figure 26: 90Vac/60Hz 15V/3A  $\Delta V=164\text{mV}$**



**Figure 27: 264Vac / 60Hz 15V/3A  $\Delta V=131\text{mV}$**

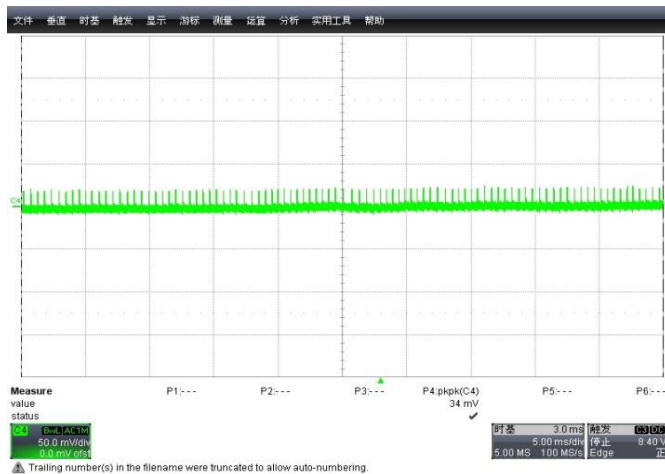

**Figure 28: 90Vac/60Hz 20V/0A  $\Delta V=34\text{mV}$**

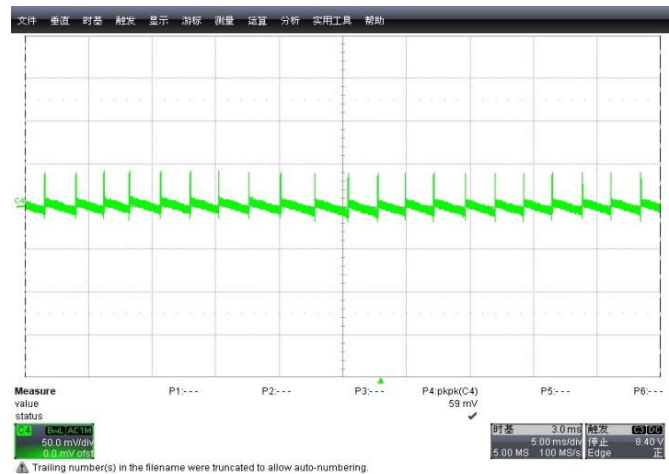

**Figure 29: 264Vac / 60Hz 20V/0A  $\Delta V=58\text{mV}$**

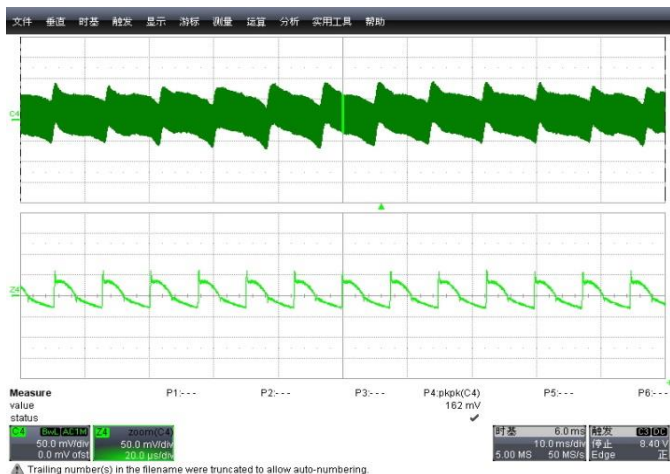

**Figure 30: 90Vac/60Hz 20V/2.25A  $\Delta V=162\text{mV}$**



**Figure 31: 264Vac / 60Hz 20V/2.25A  $\Delta V=141\text{mV}$**



### 5.2.4 Dynamic load ---0A-3A 10mS 125mA/uS( PCB End)

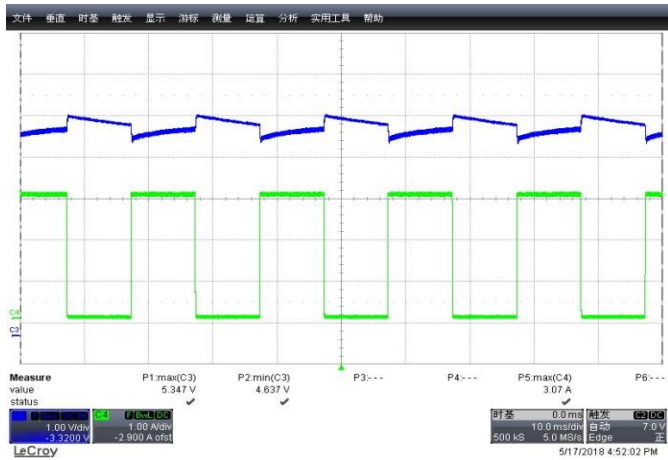

Figure 32: 5V 0 ~ 3A

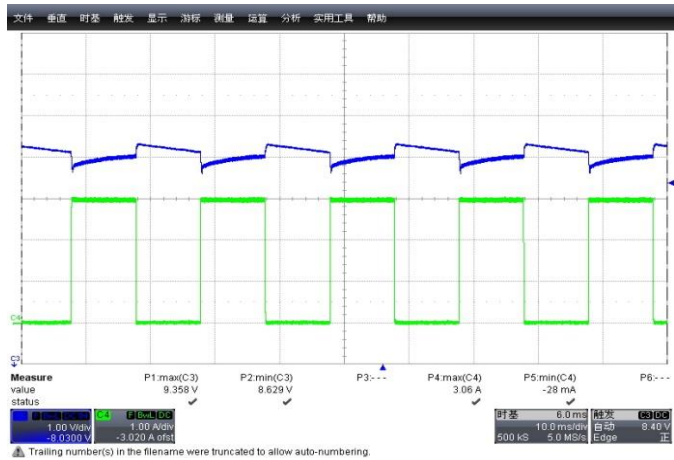

Figure 33: 9V 0 ~ 3A

Vin=90V	Vo_Undershoot(V)	Vo_Overshoot(V)
5V	4.637	5.347
9V	8.629	9.358

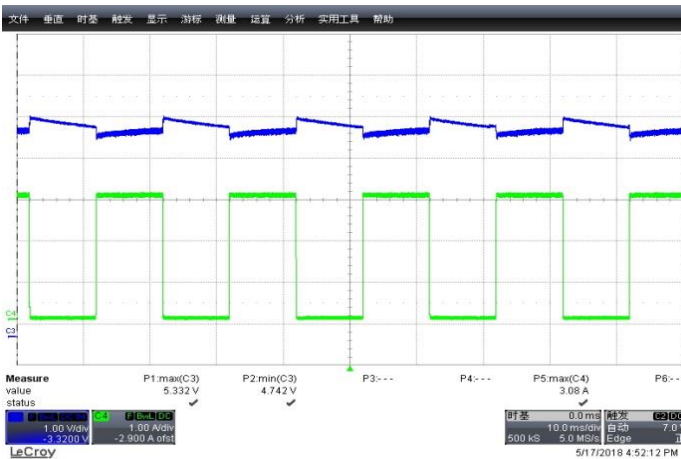
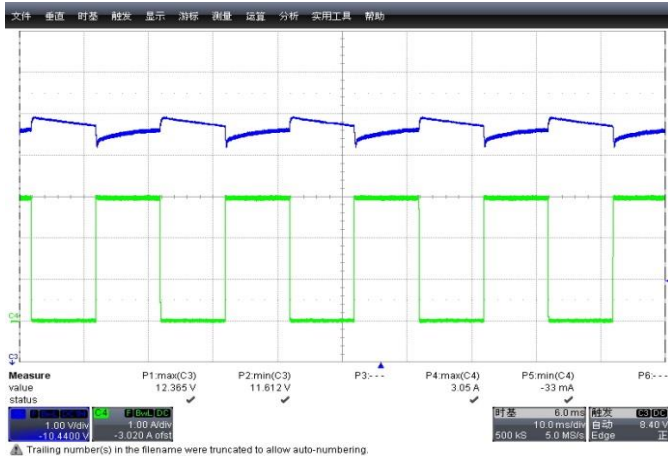

Figure 34: 5V 0 ~ 3A

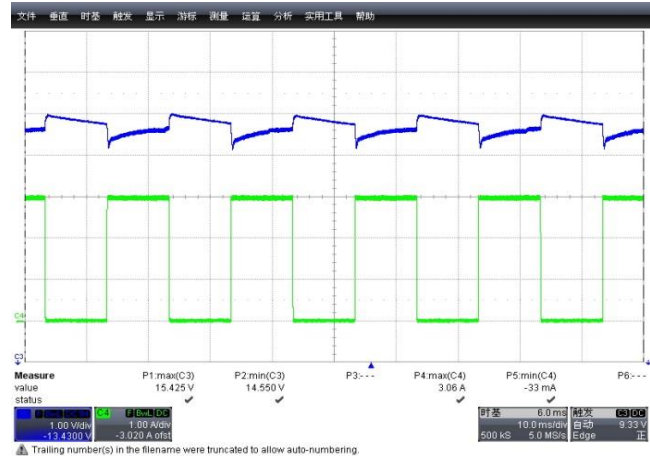

Figure 35: 9V 0 ~ 3A

Vin=264V	Vo_Undershoot(V)	Vo_Overshoot(V)
5V	4.729	5.521
9V	8.856	9.64

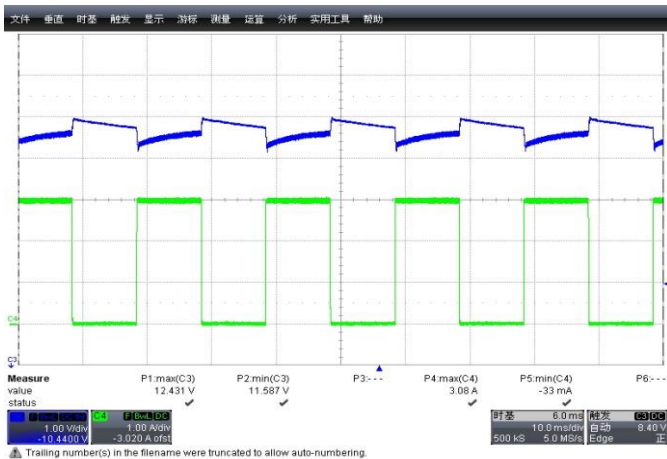

**Figure 36: 12V 0 ~ 3A**

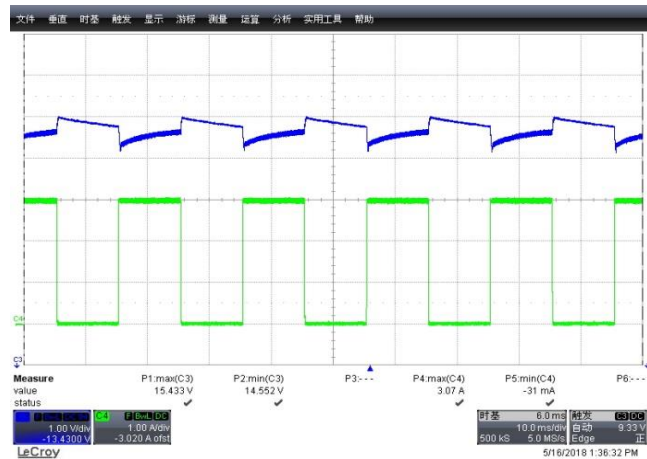

**Figure 37: 15V 0 ~ 3A**

Vin=90V	Vo_ Undershoot(V)	Vo_ Overshoot(V)
12V	11.612	12.365
15V	14.55	15.425



**Figure 38: 12V 0 ~ 3A**



**Figure 39: 15V 0 ~ 3A**

Vin=264V	Vo_ Undershoot(V)	Vo_ Overshoot(V)
12V	11.587	12.431
15V	14.552	15.433

**Figure 40: 20V 0 ~ 3A @ 90Vac**

**Figure 41: 20V 0 ~ 3A @264Vac**

Vin=90V	Vo_ Undershoot(V)	Vo_ Overshoot(V)
20V	19.627	20.412

Vin=264V	Vo_ Undershoot(V)	Vo_ Overshoot(V)
20V	19.656	20.428

### 5.2.5 Output Voltage Transition Time

#### From Step up & Step down

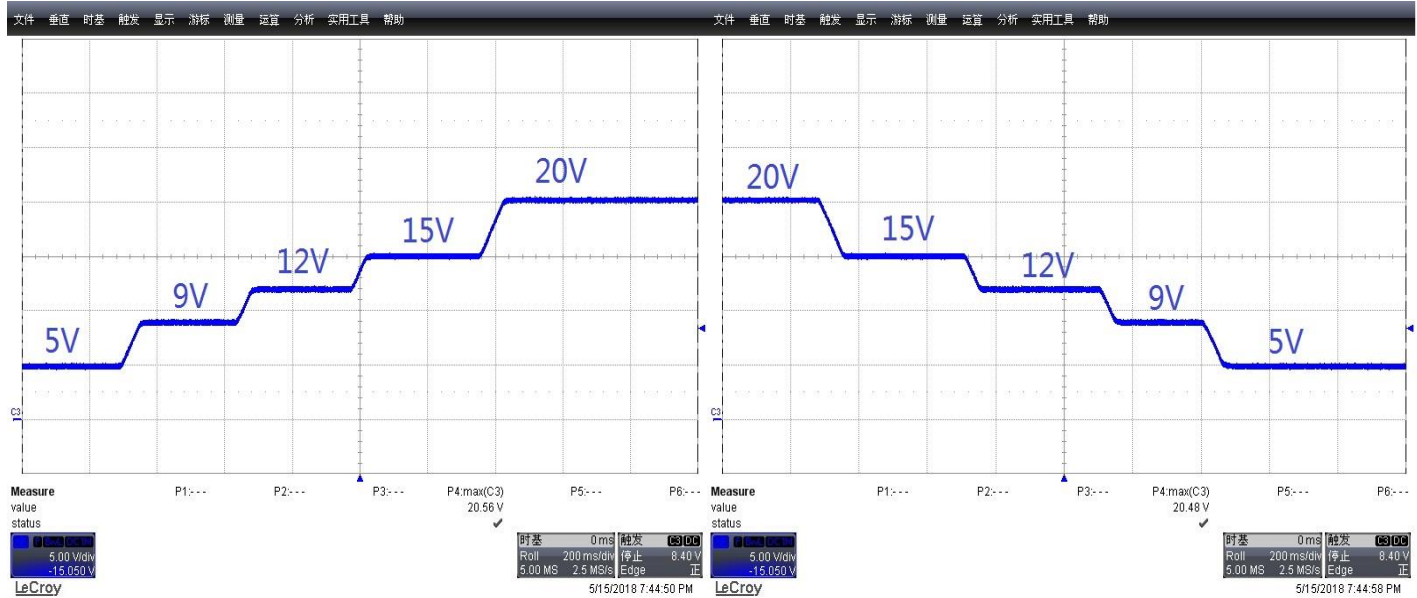

Figure 42: 5V-9V-12V-15V-20V Transition Step Up Time

Figure 43: 5V-9V-12V-15V-20V Transition Steo down Time

#### Transition time from Low to high

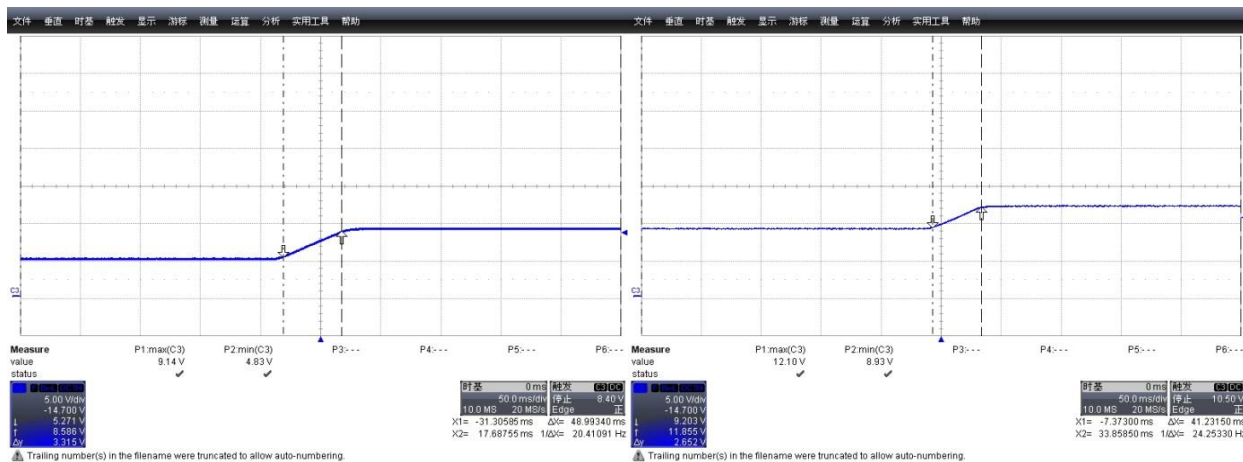
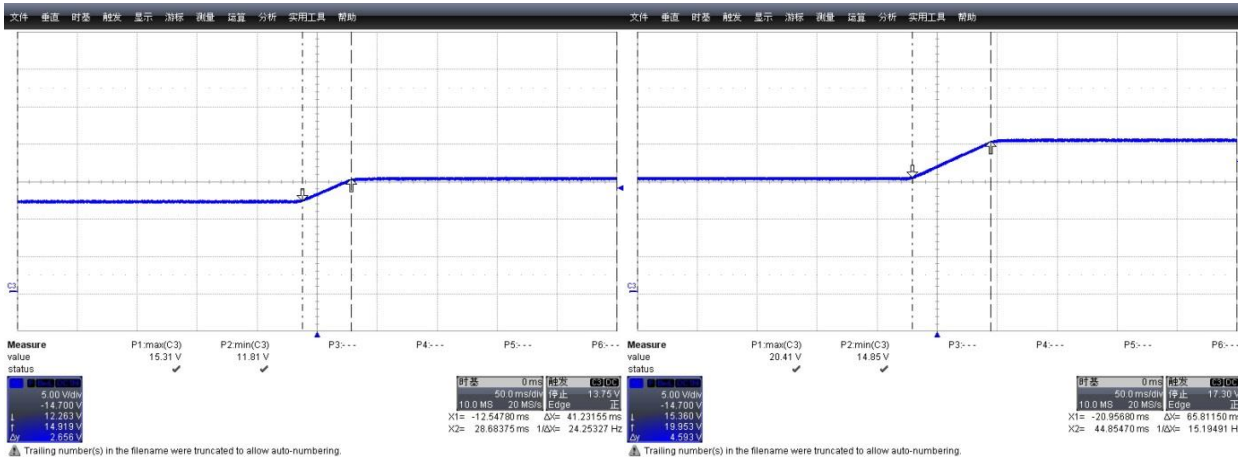

Figure 44: 5V→9V Transition upl Time: 46ms

Figure 45: 9V→12V Fall Time: 41ms



**Figure 46: 12V→15V Fall Time: 41ms**

**Figure 47: 15V→20V Fall Time: 65ms**

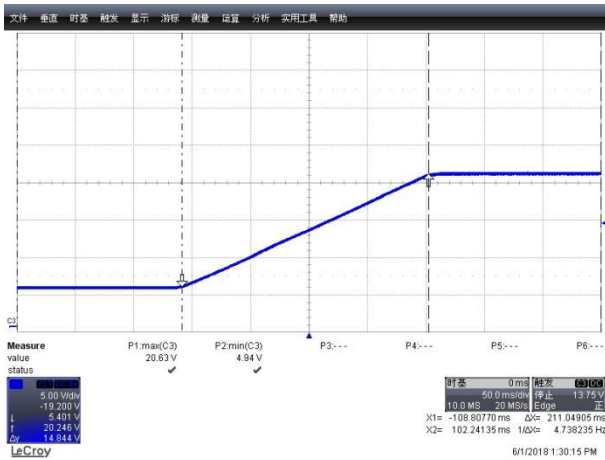

**Figure 48: 5V→20V Fall Time: 211ms**

**5.2.6 Output Voltage Transition Time from High to Low**

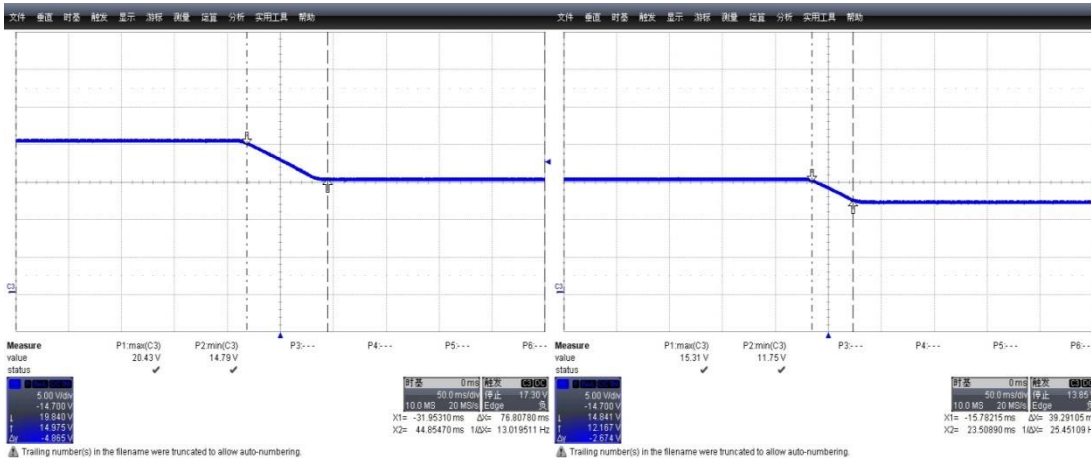

**Figure 49: 20V→15V Fall Time: 76ms**

**Figure 50: 15V→12V Fall Time: 39ms**

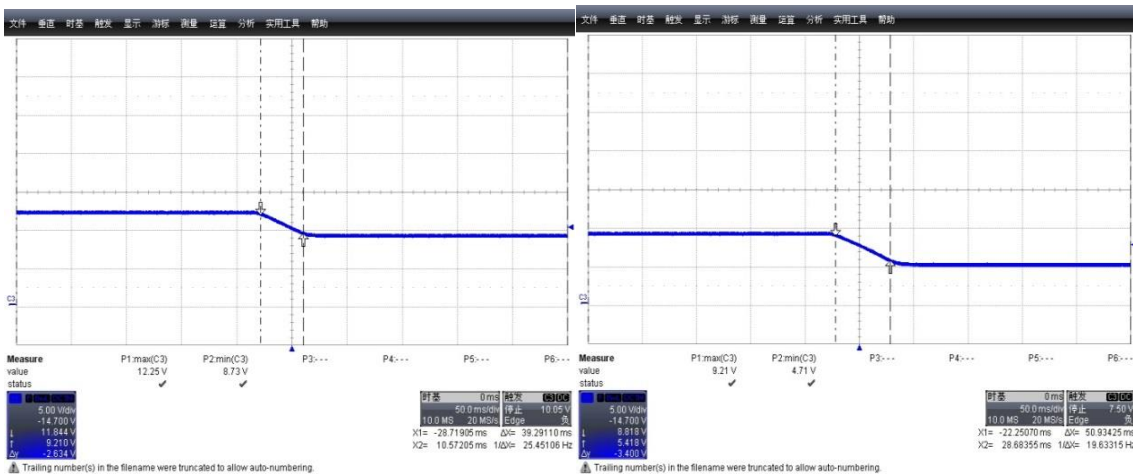

**Figure 51: 12V→9.0V Fall Time: 39ms**

**Figure 52: 9V→5V Fall Time: 50ms**

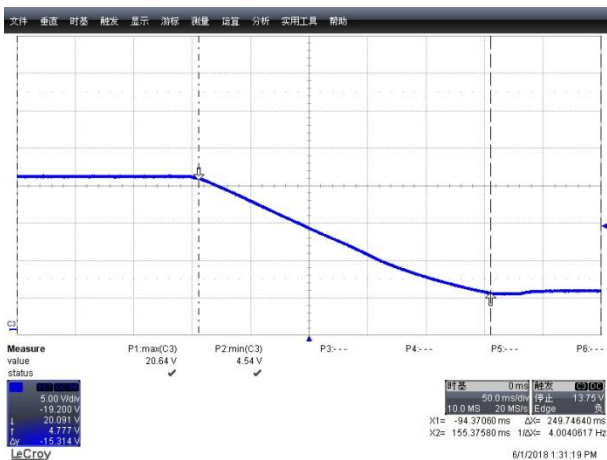

**Figure 53: 20V→5.0V Fall Time: 249ms**

### 5.2.7 Thermal Testing

Test condition AC input=90Vac Load 20V-2.25A Open Frame

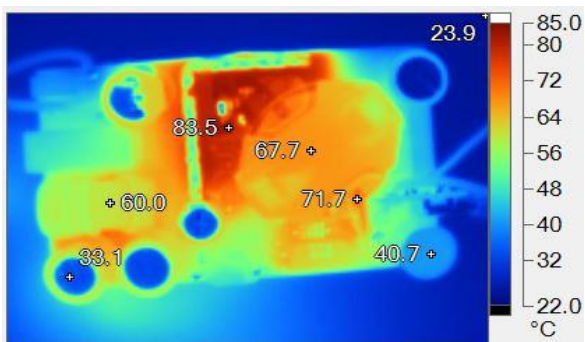

Figure 54: Components Side

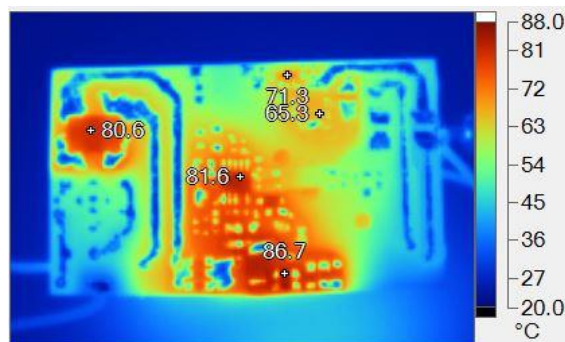

Figure 55: surface mount side

Test Items	Temperature	Unit
Ambient Temp	23.9	°C
AP3108L	81.6	°C
Q1	83.5	°C
APR346	71.3	°C
T1	71.7	°C
Q2	65.3	°C
BD1	80.5	°C

Test Condition: Vin=264Vac Vo=20V Io=2.25A Open Frame

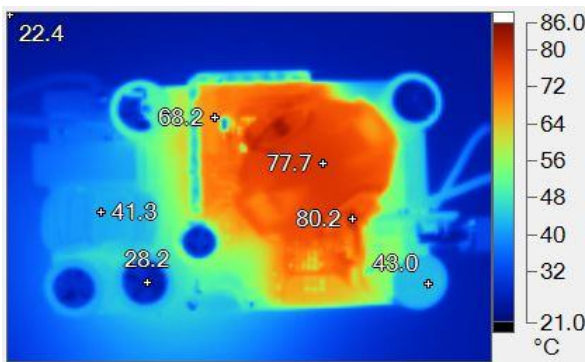

Figure 56: Components Side

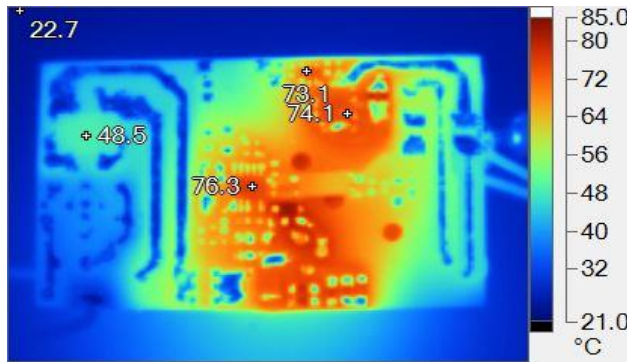

Figure 57: Surface mount side

Test Items	Temperature	Unit
Ambient Temp	22.4	°C
AP3108L	76.3	°C
Q1	68.2	°C
APR346	73.1	°C
T1	80.2	°C
Q2	74.1	°C
BD1	48.5	°C

### 5.3 EMI (CE) Testing results (Two cases Earth Ground connected or Not)

#### 5.3.1 Test Condition 115Vac 20V/2.25A (Not connecting to Earth Ground) (L) & (N)

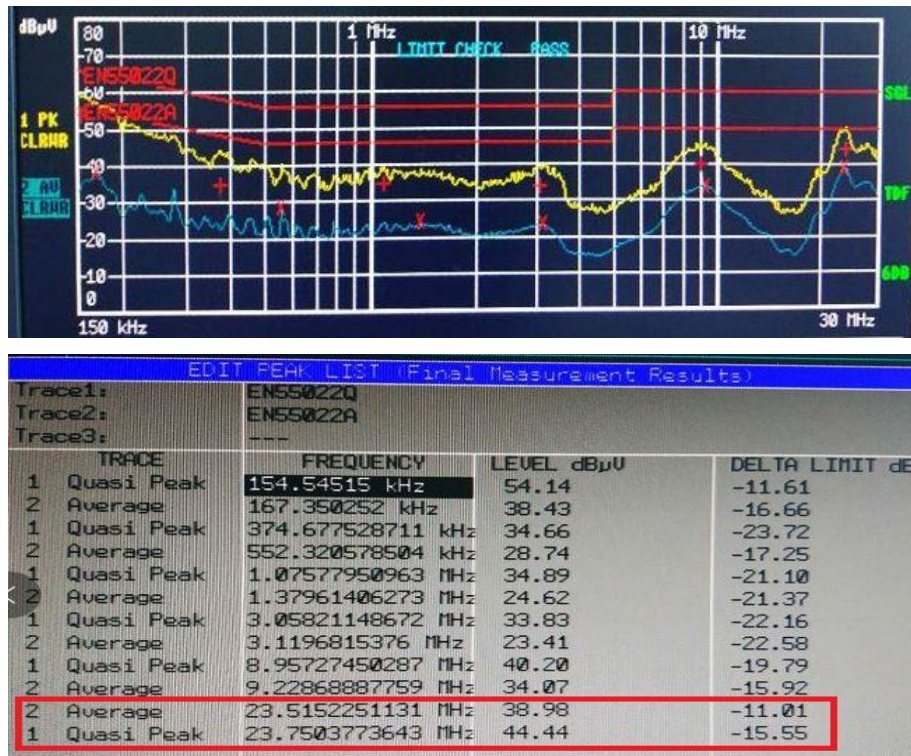

Figure 58: 115Vac/60Hz 20V/2.25A (L)

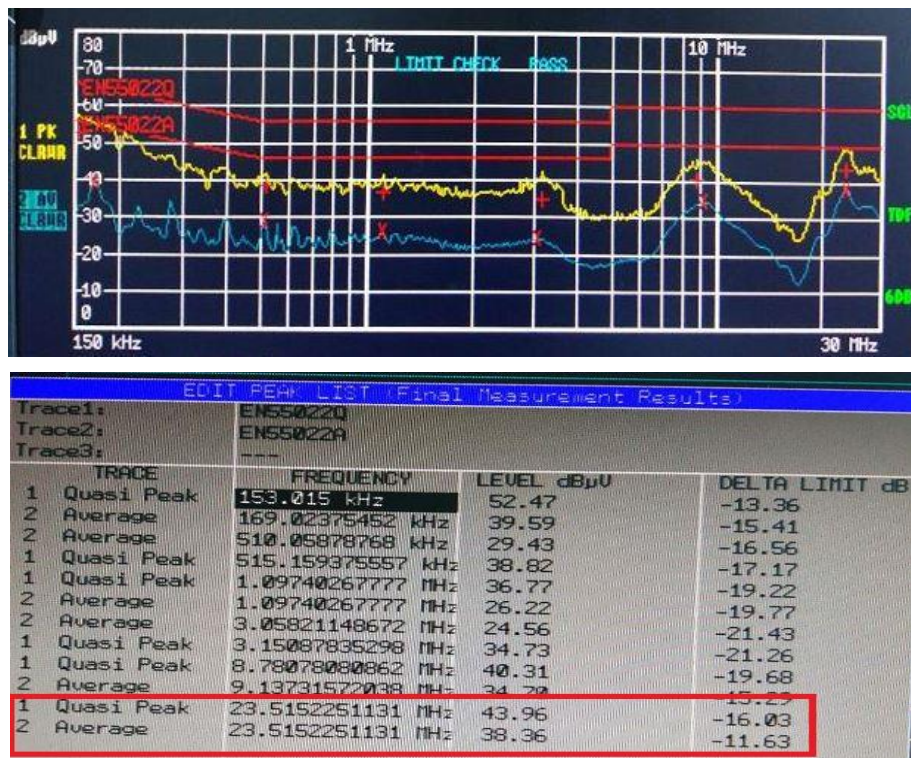

Figure 59: 115Vac/60Hz 20V/2.25A (N)

5.3.2 Test Condition 230Vac 20V/2.25A (Connect to Earth Ground) (L) & (N)

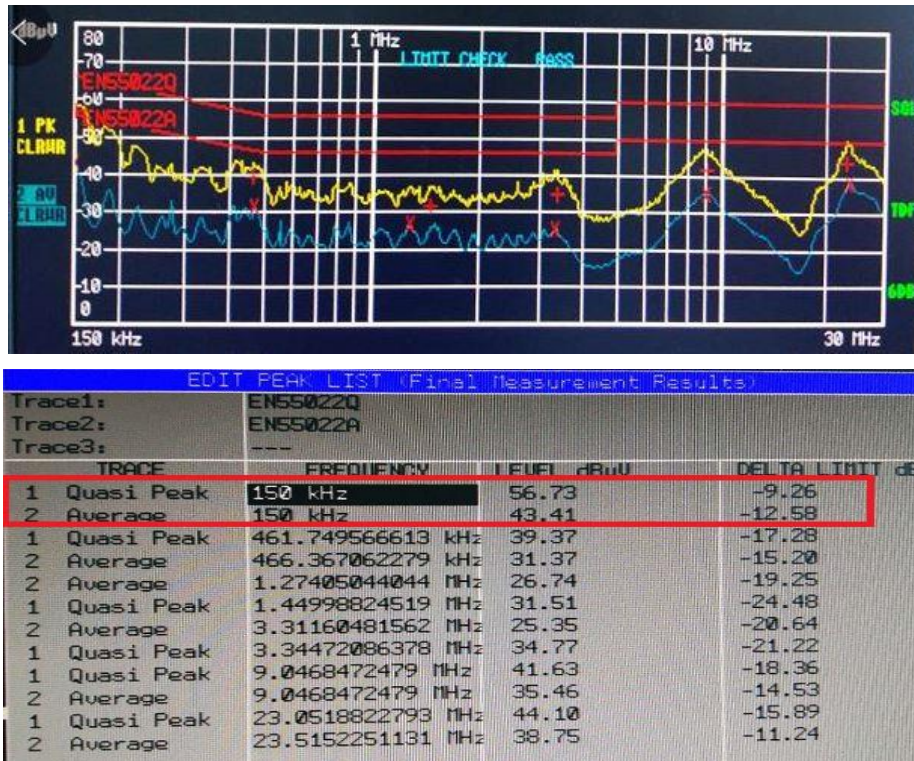

Figure 60: 230Vac/50Hz 20V/2.25A (L)



Figure 61: 230Vac/50Hz 20V/2.25A (N)



### 5.3.3 Test Condition 115Vac 20V/2.25A (Not connecting to Earth Ground) (L) & (N)

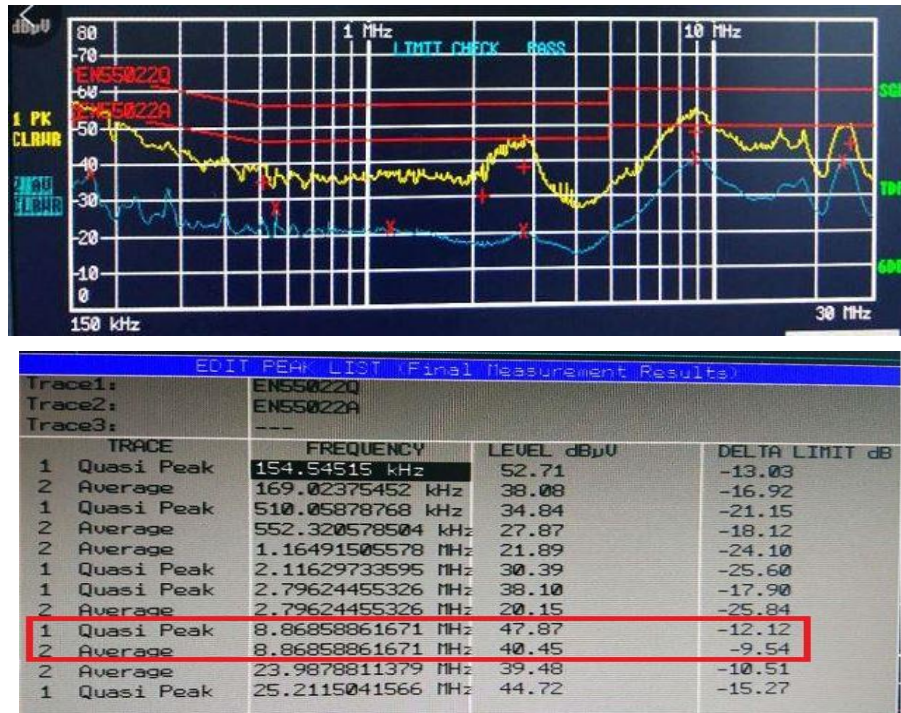

Figure 62: 115Vac/60Hz 20V/2.25A (L)

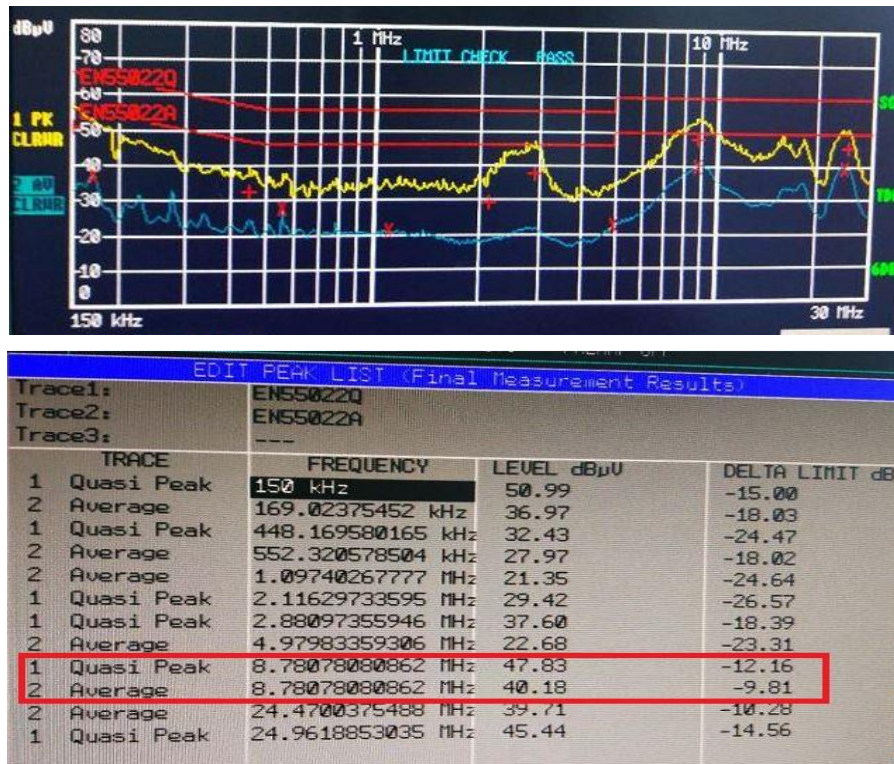

Figure 63: 115Vac/60Hz 20V/2.25A (N)

5.3.4 Test Condition 230Vac 20V/2.25A (Connect to Earth Ground) (L) & (N)

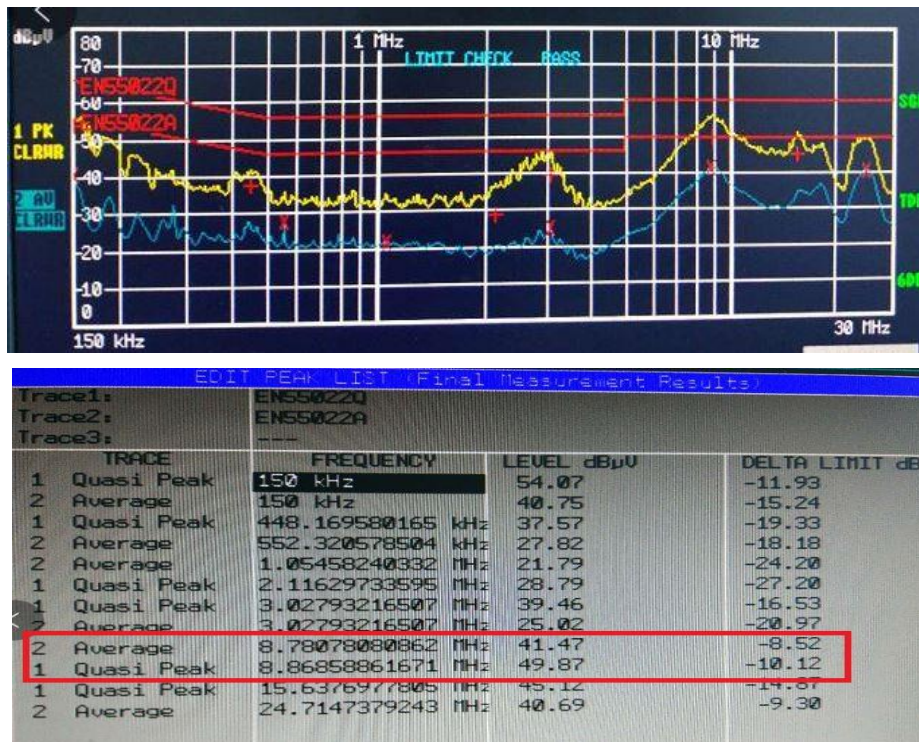

Figure 64: 230Vac/50Hz 20V/2.25A (L)

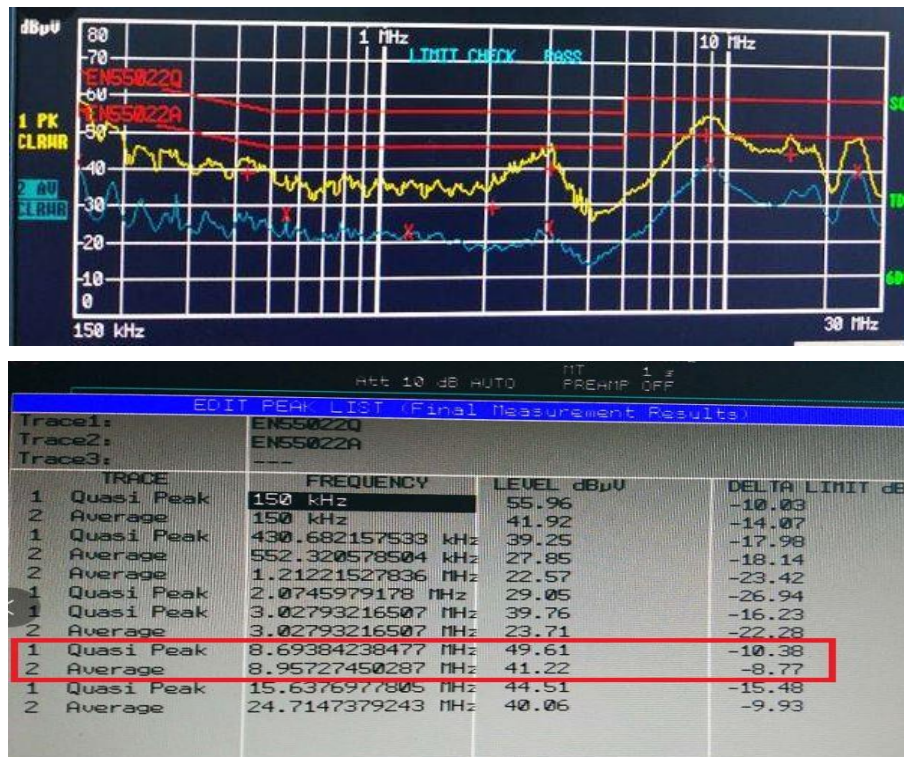

Figure 65: 230Vac/50Hz 20V/2.25A (N)

### IMPORTANT NOTICE

DIODES INCORPORATED MAKES NO WARRANTY OF ANY KIND, EXPRESS OR IMPLIED, WITH REGARDS TO THIS DOCUMENT, INCLUDING, BUT NOT LIMITED TO, THE IMPLIED WARRANTIES OF MERCHANTABILITY AND FITNESS FOR A PARTICULAR PURPOSE (AND THEIR EQUIVALENTS UNDER THE LAWS OF ANY JURISDICTION).

Diodes Incorporated and its subsidiaries reserve the right to make modifications, enhancements, improvements, corrections or other changes without further notice to this document and any product described herein. Diodes Incorporated does not assume any liability arising out of the application or use of this document or any product described herein; neither does Diodes Incorporated convey any license under its patent or trademark rights, nor the rights of others. Any Customer or user of this document or products described herein in such applications shall assume all risks of such use and will agree to hold Diodes Incorporated and all the companies whose products are represented on Diodes Incorporated website, harmless against all damages.

Diodes Incorporated does not warrant or accept any liability whatsoever in respect of any products purchased through unauthorized sales channel. Should Customers purchase or use Diodes Incorporated products for any unintended or unauthorized application, Customers shall indemnify and hold Diodes Incorporated and its representatives harmless against all claims, damages, expenses, and attorney fees arising out of, directly or indirectly, any claim of personal injury or death associated with such unintended or unauthorized application.

Products described herein may be covered by one or more United States, international or foreign patents pending. Product names and markings noted herein may also be covered by one or more United States, international or foreign trademarks.

This document is written in English but may be translated into multiple languages for reference. Only the English version of this document is the final and determinative format released by Diodes Incorporated.

### LIFE SUPPORT

Diodes Incorporated products are specifically not authorized for use as critical components in life support devices or systems without the express written approval of the Chief Executive Officer of Diodes Incorporated. As used herein:

A. Life support devices or systems are devices or systems which:

1. are intended to implant into the body, or
2. support or sustain life and whose failure to perform when properly used in accordance with instructions for use provided in the labeling can be reasonably expected to result in significant injury to the user.

B. A critical component is any component in a life support device or system whose failure to perform can be reasonably expected to cause the failure of the life support device or to affect its safety or effectiveness.

Customers represent that they have all necessary expertise in the safety and regulatory ramifications of their life support devices or systems, and acknowledge and agree that they are solely responsible for all legal, regulatory and safety-related requirements concerning their products and any use of Diodes Incorporated products in such safety-critical, life support devices or systems, notwithstanding any devices- or systems-related information or support that may be provided by Diodes Incorporated. Further, Customers must fully indemnify Diodes Incorporated and its representatives against any damages arising out of the use of Diodes Incorporated products in such safety-critical, life support devices or systems.

Copyright © 2017, Diodes Incorporated

[www.diodes.com](http://www.diodes.com)