

Application Note

AP7353 Application Information and Demo Board User Guide

Description

The AP7353 is a low dropout regulator with high output voltage accuracy, low R_{DS(on)}, high PSRR, low output noise and low quiescent current. This regulator is based on a CMOS process.

The AP7353 includes a voltage reference, error amplifier, current limit circuit and an enable input to turn it on and off. With the integrated resistor network, fixed output voltage versions can be delivered.

With its high PSRR, good line regulation and fast load transient response, the AP7353 is well suited for handheld/wearable communication equipment which require stable voltage sources.

The AP7353 is packaged in X1-WLB0707-4 (Type A1) and X2-DFN1010-4 (Type B) which allows for smallest footprint and dense PCB layout.

Features

- Low V_{IN} and Wide V_{IN} Range: 2.0V to 5.5V
- Guarantee Output Current, 250mA
- V_{OUT} Accuracy $\pm 1\%$
- Ripple Rejection 90dB at 1kHz, $I_{OUT} = 10mA$
- Ripple Rejection 70dB at 10kHz, $I_{OUT} = 250mA$
- Low Output Noise, 10 μ Vrms from 10Hz to 100kHz at 10mA
- Quiescent Current as Low as 18 μ A (Typ.)
- V_{OUT} Fixed 1.8V to 4.5V

- **Totally Lead-Free & Fully RoHS Compliant (Notes 1 & 2)**
- **Halogen and Antimony Free, Green Device (Note 3)**

Applications

- Smart Phone/PAD
- RF Supply
- Cameras
- Portable Video
- Portable Media Player
- Wireless Adapter
- Wireless Communication

Notes: 1. No purposely added lead. Fully EU Directive 2002/95/EC (RoHS) & 2011/65/EU (RoHS 2) compliant.
2. See http://www.diodes.com/quality/lead_free.html for more information about Diodes Incorporated's definitions of Halogen- and Antimony-free, "Green" and Lead-free.
3. Halogen- and Antimony-free "Green" products are defined as those which contain <900ppm bromine, <900ppm chlorine (<1500ppm total Br + Cl) and <1000ppm antimony compounds

Application Note

AP7353 Application Information and Demo Board User Guide

Typical Applications Circuit

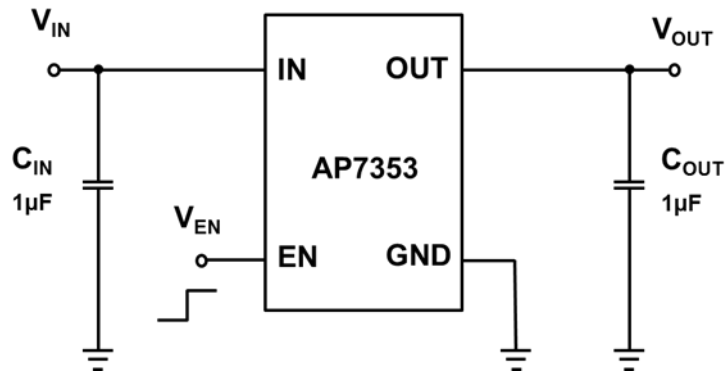

Figure1. AP7353-EVM

Absolute Maximum Ratings

Symbol	Parameter	Ratings	Unit
ESD HBM	Human Body Mode ESD Protection	>2	kV
ESD CDM	Charge Device Model	±500	V
V_{IN}	Input Voltage	6.0	V
V_{EN}	Input Voltage EN	6.0	V
V_{OUT}	Output Voltage	-0.3 to 6.0	V
I_{OUT}	Output Current	250	mA
P_D	Power Dissipation (Note 5)	800	mW
T_A	Operating Ambient Temperature	-40 to +85	°C
T_J	Operating Junction Temperature	+125	°C
T_{STG}	Storage Temperature	-55 to +150	°C

This application note contains new product information. Diodes, Inc. reserves the right to modify the product specification without notice. No liability is assumed as a result of the use of this product. No rights under any patent accompany the sale of the product.

Application Note

AP7353 Application Information and Demo Board User Guide

Recommended Operating Conditions

Symbol	Parameter	Min	Max	Unit
V_{IN}	Input Voltage	2.0	5.5	V
I_{OUT}	Output Current	0	250	mA
T_A	Operating Ambient Temperature	-40	+85	°C

Evaluation Board

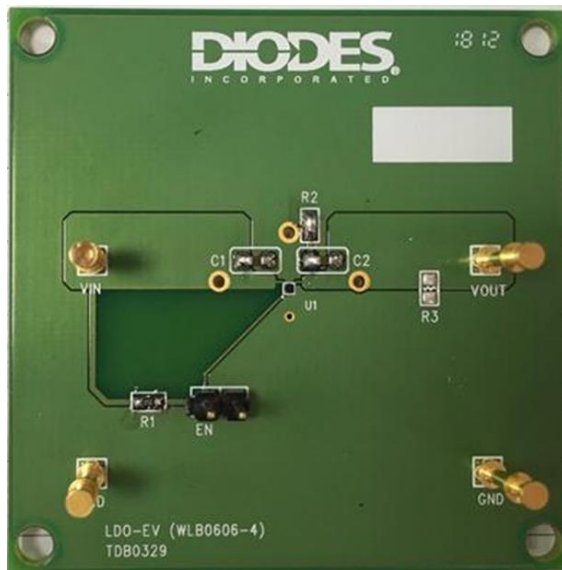

This application note contains new product information. Diodes, Inc. reserves the right to modify the product specification without notice. No liability is assumed as a result of the use of this product. No rights under any patent accompany the sale of the product.

Application Note

AP7353 Application Information and Demo Board User Guide

Quick Start Guide

The AP7353-EVM has a simple layout. To evaluate the performance of the AP7353, follow the procedure below:

1. Connect a power supply to the input terminals VIN and GND. Set VIN to VOUT+1V.
2. Connect the positive terminal of the electronic load to VOUT and negative terminal to GND.
3. For WLB package, connect EN pin to VIN through 10KΩ resistor to enable IC. Place a jumper to disable IC.
4. The evaluation board power up with output voltage.
5. Check for the proper output voltage ($\pm 1\%$) at the output terminals VOUT and GND. Measurement can also be done with a multimeter with the positive and negative leads between VOUT and GND.
6. Set the load to 250mA through the electronic load. Check for the stable operation of the VOUT signal on the oscilloscope.

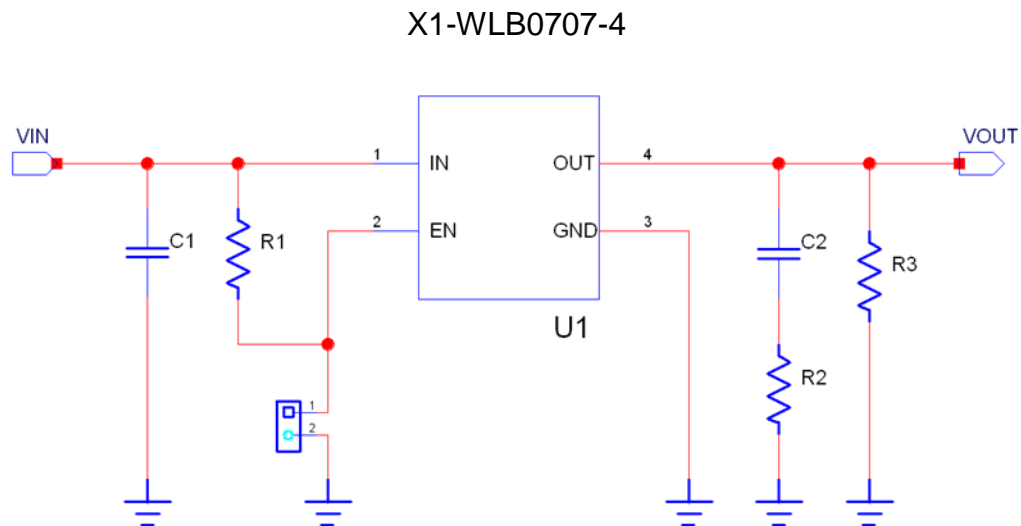
Evaluation Board Schematic

Application Note

AP7353 Application Information and Demo Board User Guide

PCB Layout

For WLB0707-4 Package

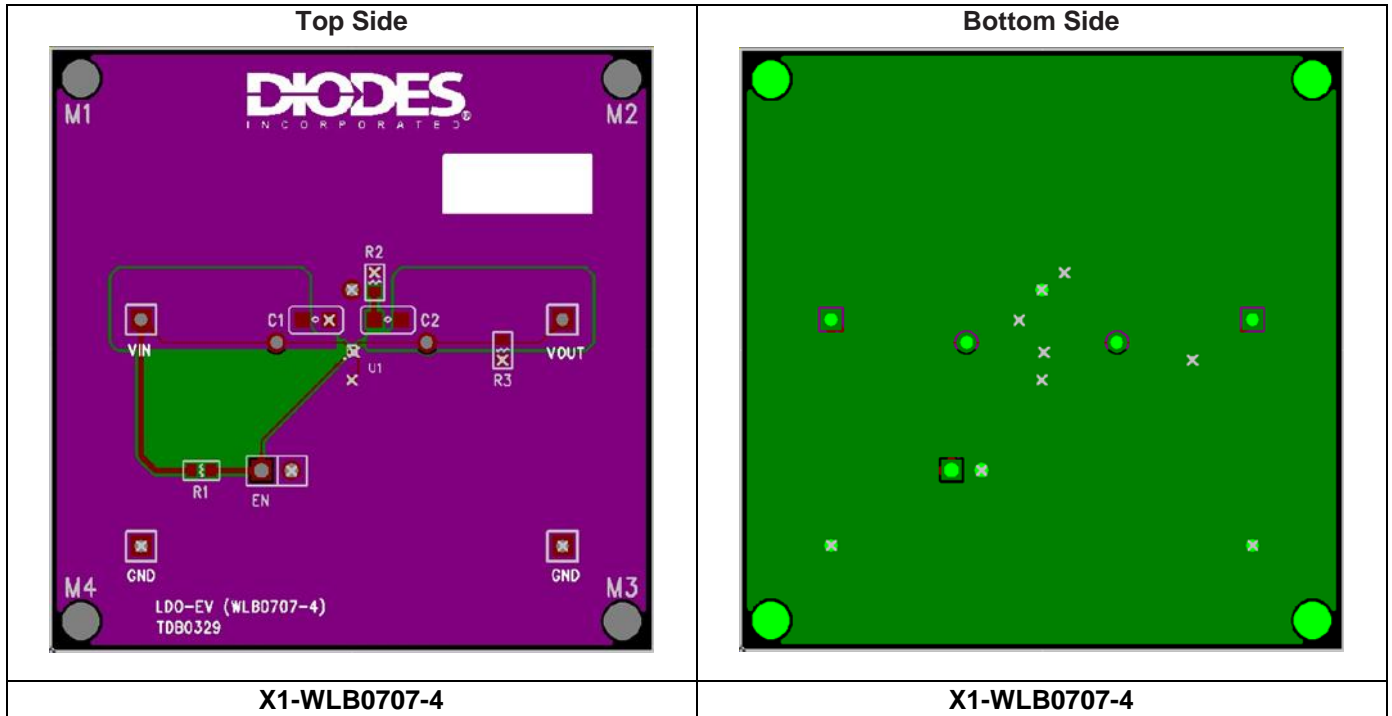

Bill of Materials

X1-WLB0707-4

Component Location	Quantity	Specification	Source	Part No.	Size
R1	1	10KΩ	YAGEO		0402
R2	0	short			
R3	0	open			
C1	1	Cap MLCC 1μF/10V/X7R	TAIYO YUDEN	LMK107B7105KA	C0603
C2	1	Cap MLCC 1μF/10V/X7R	TAIYO YUDEN	LMK107B7105KA	C0603
J1	1	0.1"*2 Header 1 and Jumper	-	-	5mm X 2.5mm
VIN,VOUT,GND	4	Header_1	-	-	2.2mm X 1.35mm
U1	1	AP7353, 250mA, LDO	Diodes Inc.	AP7353	WLB0707-4
PCB	1	LDO-EV (WLB0707-4)	Diodes Inc.	TDB0329	2000milX 2000mil

This application note contains new product information. Diodes, Inc. reserves the right to modify the product specification without notice. No liability is assumed as a result of the use of this product. No rights under any patent accompany the sale of the product.

Application Note AP7353 Application Information and Demo Board User Guide

Vendors of peripheral components

Suggested Capacitors :

Vendor	Capacitance	Type	Series
TAIYO YUDEN	Cap MLCC 1 μ F/10V/X7R	SMD	LMK107B7105KA

Suggested Resistor :

Vendor	Type	Series
YAGEO	SMD	RC0402FR-SK

Application Note

AP7353 Application Information and Demo Board User Guide

IMPORTANT NOTICE

DIODES INCORPORATED MAKES NO WARRANTY OF ANY KIND, EXPRESS OR IMPLIED, WITH REGARDS TO THIS DOCUMENT, INCLUDING, BUT NOT LIMITED TO, THE IMPLIED WARRANTIES OF MERCHANTABILITY AND FITNESS FOR A PARTICULAR PURPOSE (AND THEIR EQUIVALENTS UNDER THE LAWS OF ANY JURISDICTION).

Diodes Incorporated and its subsidiaries reserve the right to make modifications, enhancements, improvements, corrections or other changes without further notice to this document and any product described herein. Diodes Incorporated does not assume any liability arising out of the application or use of this document or any product described herein; neither does Diodes Incorporated convey any license under its patent or trademark rights, nor the rights of others. Any Customer or user of this document or products described herein in such applications shall assume all risks of such use and will agree to hold Diodes Incorporated and all the companies whose products are represented on Diodes Incorporated website, harmless against all damages.

Diodes Incorporated does not warrant or accept any liability whatsoever in respect of any products purchased through unauthorized sales channel.

Should Customers purchase or use Diodes Incorporated products for any unintended or unauthorized application, Customers shall indemnify and hold Diodes Incorporated and its representatives harmless against all claims, damages, expenses, and attorney fees arising out of, directly or indirectly, any claim of personal injury or death associated with such unintended or unauthorized application.

Products described herein may be covered by one or more United States, international or foreign patents pending. Product names and markings noted herein may also be covered by one or more United States, international or foreign trademarks.

This document is written in English but may be translated into multiple languages for reference. Only the English version of this document is the final and determinative format released by Diodes Incorporated.

LIFE SUPPORT

Diodes Incorporated products are specifically not authorized for use as critical components in life support devices or systems without the express written approval of the Chief Executive Officer of Diodes Incorporated. As used herein:

A. Life support devices or systems are devices or systems which:

1. are intended to implant into the body, or
2. support or sustain life and whose failure to perform when properly used in accordance with instructions for use provided in the labeling can be reasonably expected to result in significant injury to the user.

B. A critical component is any component in a life support device or system whose failure to perform can be reasonably expected to cause the failure of the life support device or to affect its safety or effectiveness.

Customers represent that they have all necessary expertise in the safety and regulatory ramifications of their life support devices or systems, and acknowledge and agree that they are solely responsible for all legal, regulatory and safety-related requirements concerning their products and any use of Diodes Incorporated products in such safety-critical, life support devices or systems, notwithstanding any devices- or systems-related information or support that may be provided by Diodes Incorporated. Further, Customers must fully indemnify Diodes Incorporated and its representatives against any damages arising out of the use of Diodes Incorporated products in such safety-critical, life support devices or systems.

Copyright © 2020, Diodes Incorporated

www.diodes.com