

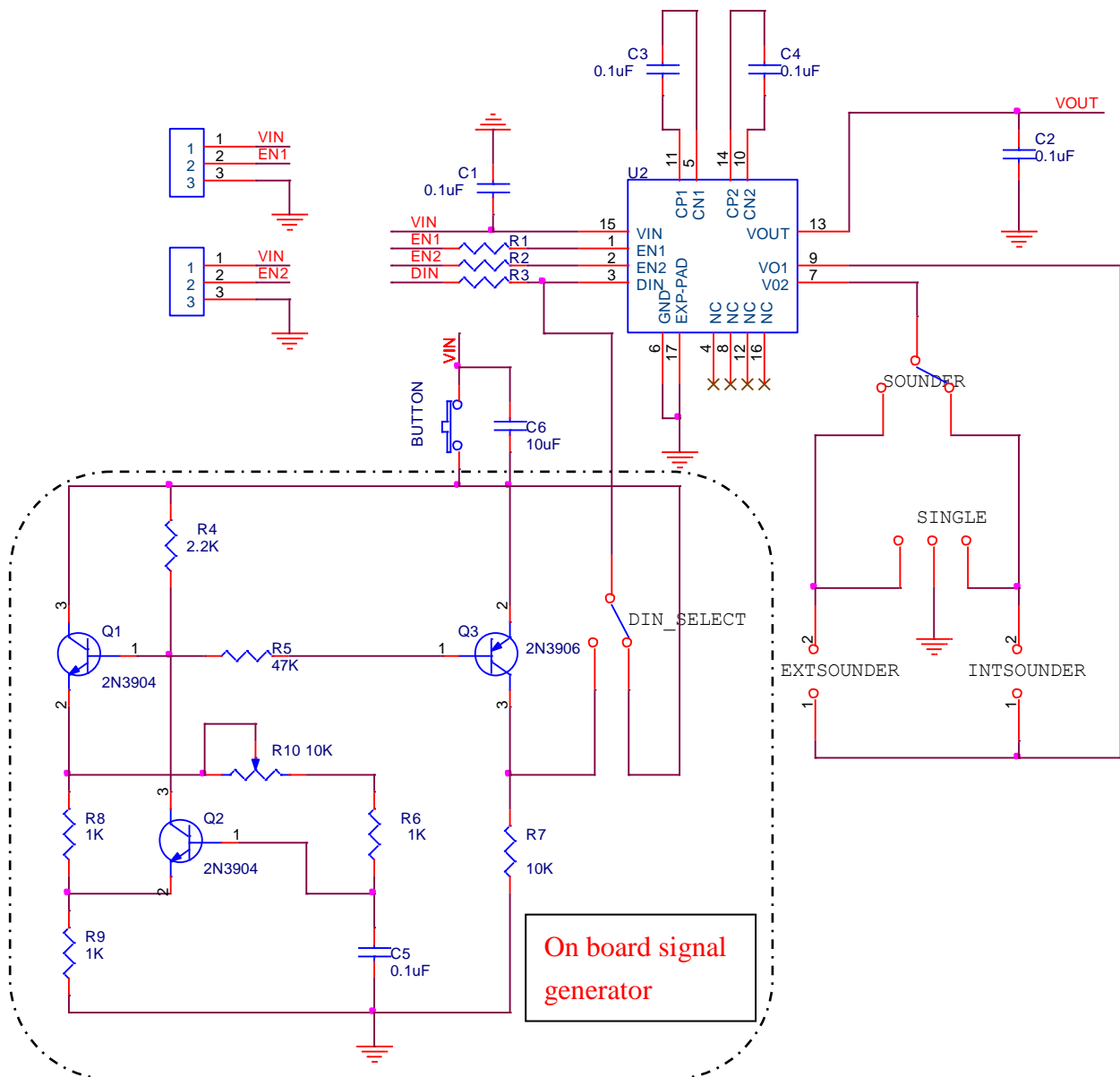

## 2. Key Features

- ◆ Supply voltage Range From 2.3 V to 5.5V
- ◆ 18Vpp Output from a 3V Supply
- ◆ Multi-Mode Charge Pump (1x/2x/3x)
- ◆ No Voltage Cross Output At Shutdown Mode
- ◆ Auto standby when no signal applying in DIN
- ◆ Low Current Consumption

## 3. EV Board Schematic



This application note contains new product information. Diodes, Inc. reserves the right to modify the product specification without notice. No liability is assumed as a result of the use of this product. No rights under any patent accompany the sale of the product.

## 4. EV-Board PAM8904 EB41AA Description

PAM8904 EB41AA is designed for evaluated PAM8904. The PAM8904 is a switching driver with multi mode charge pump for piezo-sounder. It can drive outputs up to 18Vpp from 3V supply. For adjusting the piezoelectric sounder sound volume, the charge pump can operate in either of a 1x, 2x or 3x mode.

PAM8904 features auto standby, which makes it suitable for battery application, such as health care system, alarm clock and security device.

The board is targeted to be used in providing a simple and convenient evaluation environment for the PAM8904.

## 5. EV Board View and Jack Description

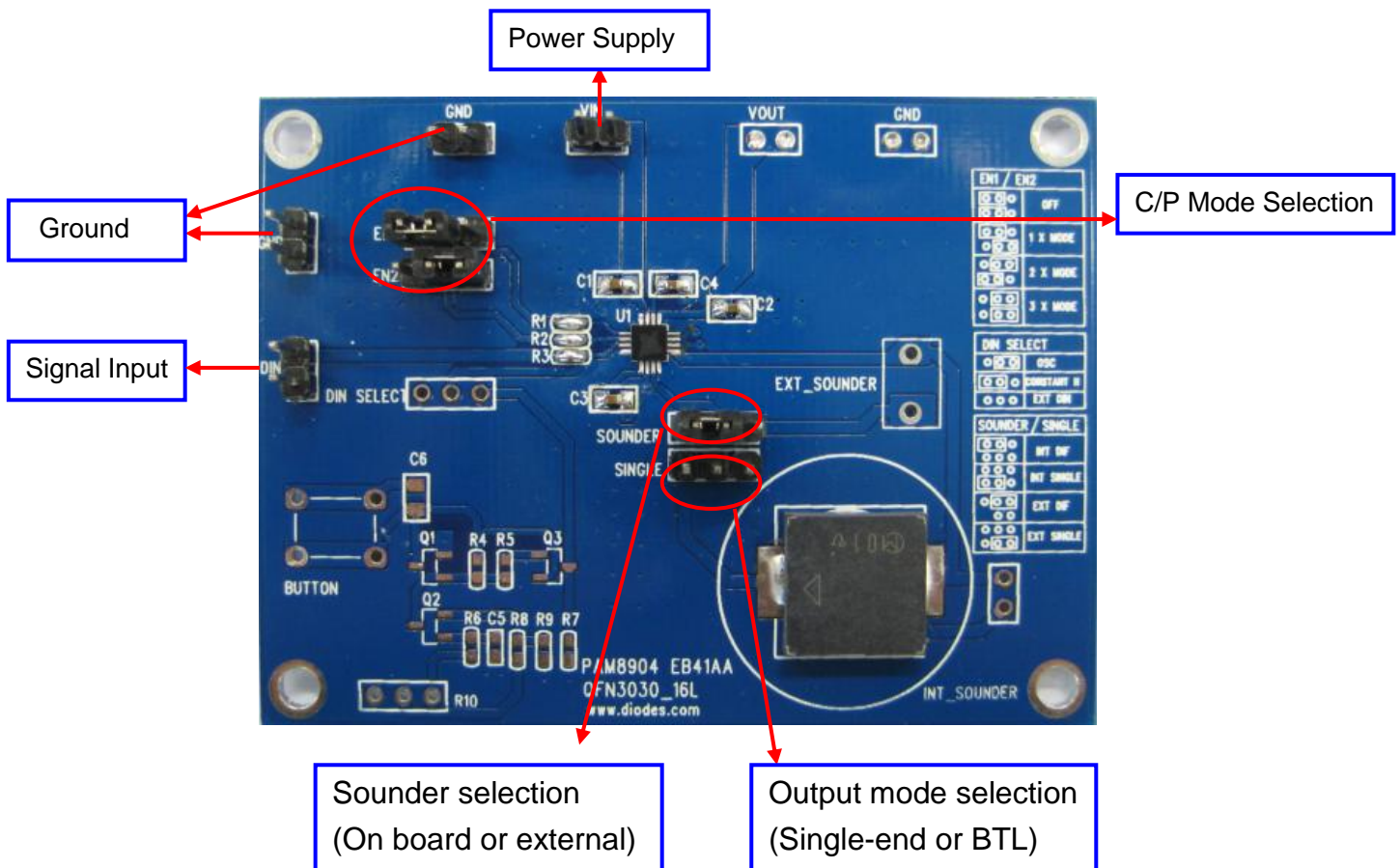

This application note contains new product information. Diodes, Inc. reserves the right to modify the product specification without notice. No liability is assumed as a result of the use of this product. No rights under any patent accompany the sale of the product.

## 6. EV board operational sequence:

There are several jumper settings available which are used to configure the board for various operation configurations. All jumper settings are illustrated by on board silk screen printings.

- (1) The on-board EN1 and EN2 jumpers are used for selection between power down, 1X, 2X and 3X charge pump operating modes. The EN1 and EN2 pins can also be used for external control but in this case the EN1 and EN2 jumpers must be removed.
- (2) The DIN\_SELECT jumper determines the signal source of DIN. The OSC on the board is not supplied. EXT\_DIN is used to select an external DIN signal for the DIN pin.
- (3) The SOUNDER / SINGLE jumper setting is used to choose between single ended and differential load configurations as well as between driving either the on board piezo SOUNDER or an externally connected piezo SOUNDER.
- (4) The VOUT pin is available together with GND for measurement of the charge pump output voltage.

## 7. EV Board BOM List

Item	Value	Type	Rating	Description	Vender and port
C1,	0.1uF	X5R/X7R, Ceramic 0603	25V	Input coupling CAP	TAIYO YUDEN UMK212B7104KG-T
C3, C4	0.1uF	X5R/X7R, Ceramic 0603	25V	Charge pump CAP	TAIYO YUDEN UMK212B7104KG-T
C2	0.1uF	X5R/X7R, Ceramic 0603	25V	Output CAP	TAIYO YUDEN UMK212B7104KG-T
R1,R2,R3	0ohm	0603	1%		
INT_SOUNDER		PKLCS1212 E4001-R1		Piezo-sounder	muRata
IC1	PM8904	QFN3030- 16L			

This application note contains new product information. Diodes, Inc. reserves the right to modify the product specification without notice. No liability is assumed as a result of the use of this product. No rights under any patent accompany the sale of the product.

## 8. PCB Layout Example

Top Layer

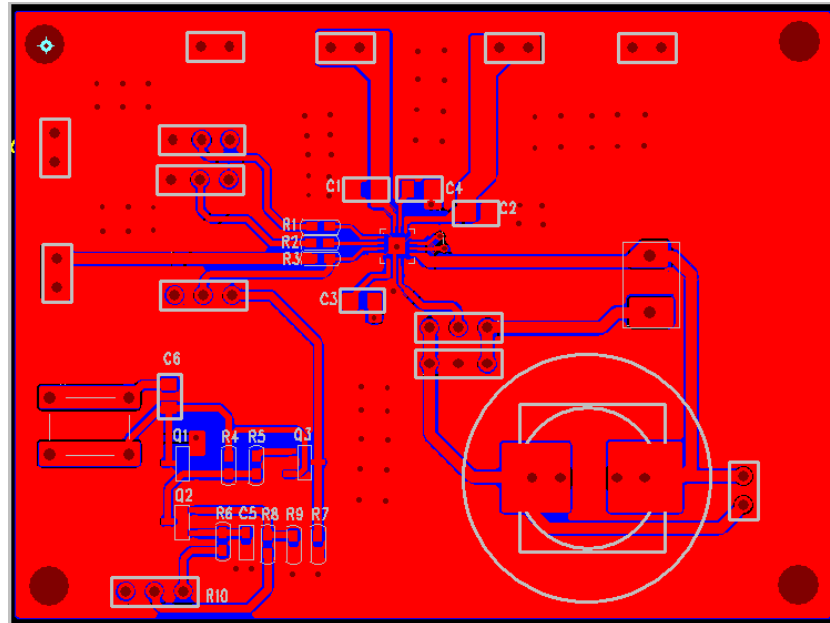

Bottom Layer

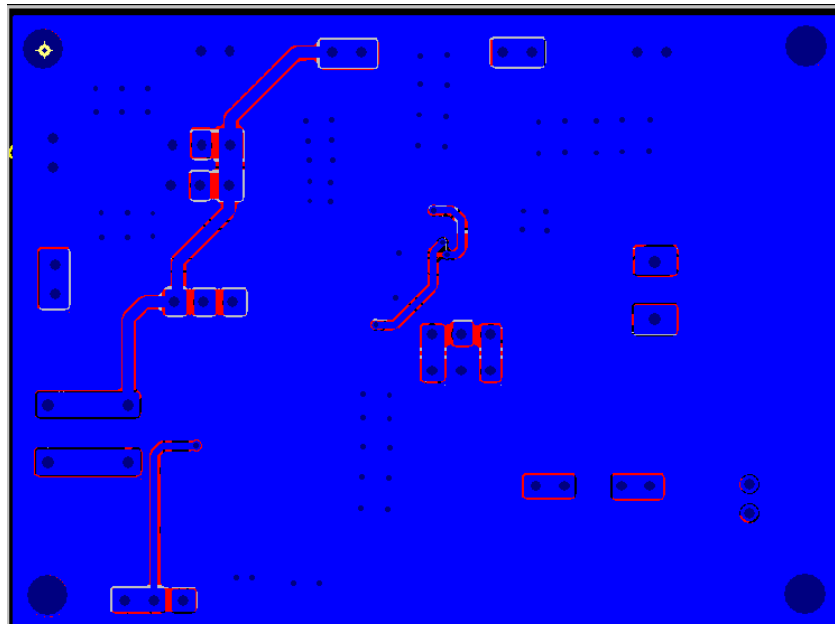

This application note contains new product information. Diodes, Inc. reserves the right to modify the product specification without notice. No liability is assumed as a result of the use of this product. No rights under any patent accompany the sale of the product.