

PI7C8150B Asynchronous Feature

By Mohamad Tisani

Introduction

The PCI bus has been used for more than fifteen years and is still running strong. This interface is being developed in PCs, Servers, Notebooks, Datacom and Telecom Systems. With many different PCI devices and peripherals being placed in systems today, the need for PCI Bridges becomes essential. Pericom has added the PI7C8150B Asynchronous PCI-to-PCI Bridge to its growing list of PCI Bridge products. The PI7C8150B is based on the existing PI7C8150, which is in full production. The new PI7C8150B introduces asynchronous mode support as well as enhanced performance. In this application note, we will describe how to use the asynchronous feature of the PI7C8150B.

Benefits

The asynchronous feature will allow designers to have the flexibility to run the Primary and Secondary busses at asynchronous speeds. This is important especially for interfacing to slower legacy devices. The typical synchronous bridge only allows the secondary bus to run at either the same speed or half the speed of the primary bus. Pericom's asynchronous PI7C8150B will allow the primary and secondary busses to run at any speed between 25 MHz and 66 MHz. For example, the primary can be at 25 MHz while the secondary bus can be at 66 MHz.

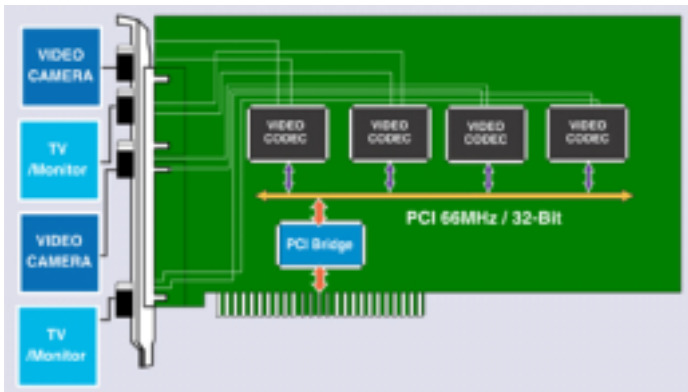

How does it work in asynchronous mode?

In Asynchronous mode, the designer will drive the primary clock at a speed between 25 MHz to 66 MHz onto P_CLK (Pin number 45 or ball number M4). The designer will also provide the Asynchronous Clock onto the pin Mask_in/Async_CLK. (pin number 126 or ball number K15). In order to place the device in asynchronous mode you will also need to drive the pin MS 0 and MS1 to one. In Asynchronous mode, the secondary clock outputs S_Clkout (0:9) are used for devices on the secondary bus and S_clkin. . See the Figure below.

SCLKOUT(0:9) will be half the frequency of the Asynch_CLK if the signal CLK_RATE is LOW. If CLK_RATE is HIGH, then SCLKOUT(0:9) is the same frequency as Asynch_CLK.

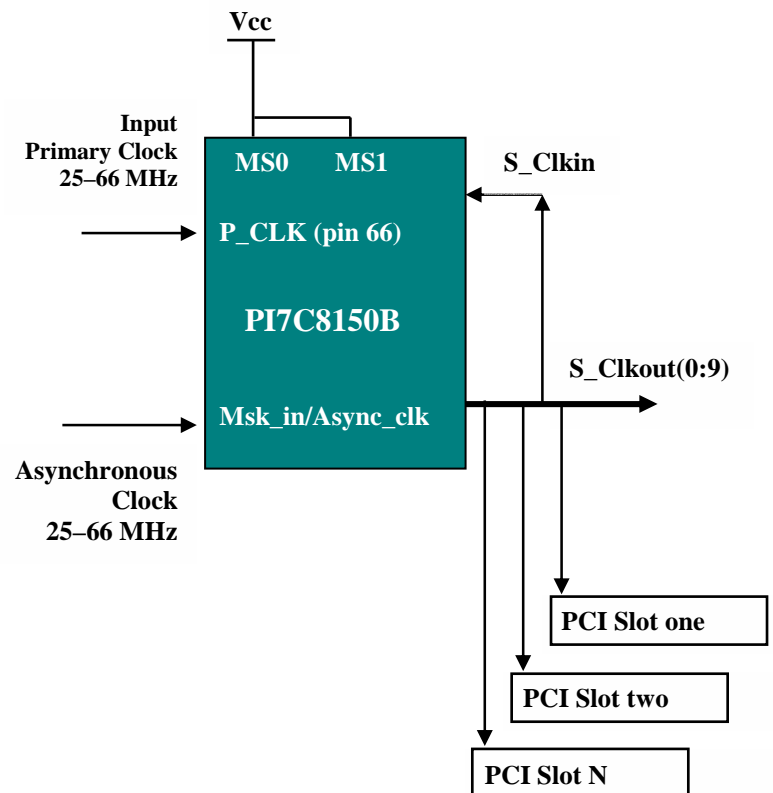

Conclusion

The PI7C8150B can be used in synchronous and asynchronous modes. In Asynchronous mode the Bridge will also provide the secondary clock to the 8150B device as well as the clocks for the secondary devices. The Asynchronous feature is very useful since it will allow the designer to run the primary and secondary busses at totally independent clock speeds and alignment.