

DN94

High performance rectifiers significantly improve server power supply efficiency

Dr Yong Ang, Diodes Incorporated

Introduction

Alternative approaches can improve the existing methods of using Schottky diodes in high reliability, high availability and low downtime server standby power supplies. Two different secondary circuit approaches, including synchronous rectification and Super Barrier Rectifier (SBR™) were used to find the highest practical efficiency in a +5VSB power supply capable of delivering 27W peak power. Efficiency improvements were measured in an experimental converter, at 3.5% for synchronous rectification and 0.5% for SBR over the Schottky solution. This design note discusses the details.

Server standby power supplies

Desktop derived servers are designed to operate in high reliability and availability application environments where it must be working continuously with extremely low unscheduled downtime. Typically the architecture of the power supply follows a two stage conversion approach as shown in Figure 1. The front end stage is a Continuous Conduction Mode active power factor correcting Boost converter and delivering a constant 400V DC rail to a downstream forward DC-DC converter processing the tightly regulated +/-12V, +5V and +3.3V rails required by the system.

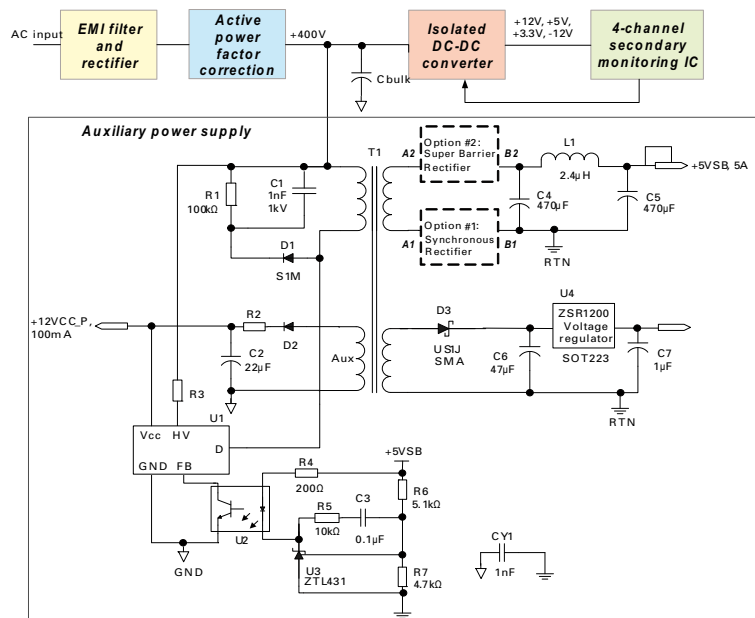

Figure 1 - Server power supply architecture diagram

A second flyback DC-DC converter is required to generate a isolated 5V output with $\pm 5\%$ tolerance. This voltage source is active whenever the input AC voltage source is applied and remains operational even if the main output rails from the isolated DC-DC converter are disabled.

DN94

In the 'standby' or 'off' mode, it delivers power to the external circuits that perform soft power control, Wake On LAN (WOL), Wake On Modem (WOM) or suspend state activities. If an external USB device stimulates the server to transit from Standby to Active mode, the power supply could be required to provide 5A current for a few seconds, therefore the power supply must be designed to that peak power.

A high level of integration is desirable for the standby circuit which is made feasible by using a PWM regulator that incorporates a 650V MOSFET. The PWM regulator also provides over current protection to ensure the +5VSB supply will not be damaged under output fault conditions. The converter is normally designed for Critical Conduction Mode to reduce MOSFET turn on switching loss. Furthermore, the flyback transformer size can be reduced owing to the lower average energy storage whilst its smaller magnetizing inductance also yields a better transient line/load response. At light loads the IC will operate in skip cycle mode, reducing its switching losses and ensuring high efficiency throughout the load range.

The secondary windings of the transformer are rectified and filtered to produce two outputs, where the +5Vstb main output channel is closed loop regulated through an optocoupler U2. The low power +12VCC_S is used to supply the supervisory IC monitoring the 12V, +5V and +3.3V rails. The supervisory IC will normally shut down the active PFC stage and the main downstream forward converter if those outputs are not sensed at their nominal value. In the design example, a third bias output +14VCC_P is capable of supplying 100mA to the PFC controller and forward converter PWM regulator ICs during normal operation.

Critically, much of the flyback converter inefficiency is caused by the Schottky diodes normally used for secondary side rectification on the +5VSB output. Replacing the old existing diode technologies with a more efficient rectifier is recognized as a clear means of drastically improving power supply efficiency. Two different secondary side rectifier approaches in Figure 1 were considered including synchronous MOSFET rectifier and the Super Barrier Rectifier.

High performance rectifier #1. Synchronous rectification with ZXGD3101

The ZXGD3101 can emulate the performance of an ideal rectifier by driving a synchronous MOSFET effectively. Figure 2 shows a typical circuit configuration for low side rectification. The controller can draw its power directly from the regulated +12VCC_S output via emitter-follower transistor Q1. In other cases where a regulated voltage above 8V is unavailable, the recommendation is to provide a dedicated supply through auxiliary transformer winding. R_{REF} and R_{BIAS} are chosen to be 3k Ω and 1.8k Ω which sets the controller turn-off threshold value to -20mV.

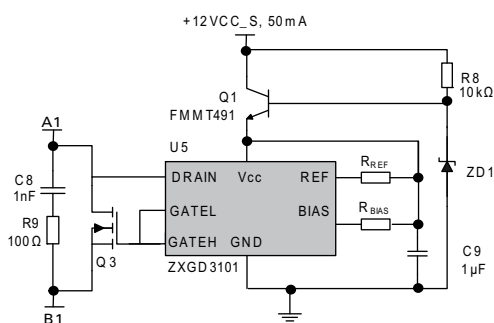

Option #1: Synchronous rectifier

Figure 2 - Synchronous rectifier control circuit

The MOSFET current is sensed by the high voltage amplifier using its on-state resistance as a shunt resistor which produces a negative Drain voltage relative to ground. The gate output from the controller then varies accordingly depending on the level of this sensed voltage. This causes the Gate voltage to reduce as the Drain current falls, ensuring a rapid turn-off transition when the stored energy in the transformer is fully released to the output. Figure 3 shows the ZXGD3101's Gate voltage when FQP65N06 - 16mΩ, 60V is used as the synchronous MOSFET. The Gate voltage reaches 10.3V when the MOSFET current was high to achieve low resistance.

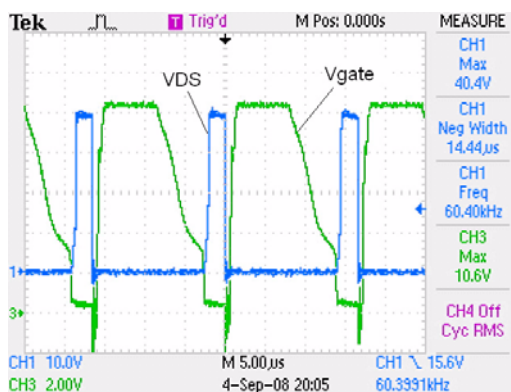

Figure 3 - Voltages of the synchronous MOSFET at full load

Theoretically, reducing the resistance of the MOSFET will further increase the efficiency of the power supply at heavy load. However, this is not entirely true because a very low resistance MOSFET yields a small voltage drop across the Drain and the subsequent sensed voltage is unable to induce the ZXGD3101 to produce a high enough Gate voltage. Therefore, the full capability of the MOSFET is not utilized due to inadequate enhancement. Figure 4 illustrates that the peak Gate voltage on the 3.3mΩ, 75V MOSFET IRFB3077PbF is less than 5V and the Gate voltage ringing at MOSFET turn-on transition incurs additional gate charge loss and further deteriorates the efficiency. If the voltage across the MOSFET drops below the turn-off threshold level, the device will switch between its off state, in which case the body diode is conducting, and its on state, in which case the voltage drop is the current multiplied by the on resistance of the MOSFET. All these could cause less than 1% efficiency improvement over a higher resistance MOSFET.

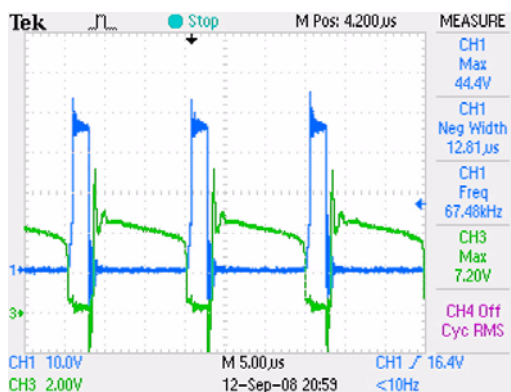
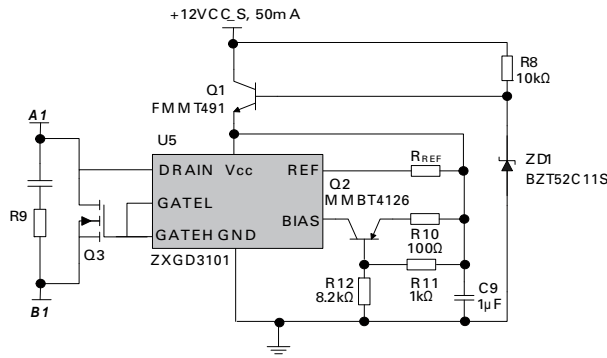

Figure 4 - Inadequate gate enhancement of low resistance MOSFET

DN94

To further improve the circuit, use the additional circuit comprising of Q2, R10, R11 and R12 in Figure 5. The transistor constant current source is set up to supply the BIAS pin on the ZXGD3101 instead of a fixed value resistor. The values for R1, R2 and R3 are selected to source approximately 5mA into the 'BIAS' pin to set the controller's threshold voltage to -20mV. The constant current source improves the Gate voltage hold up after the MOSFET's turn on in Figure 6, as a high Gate Voltage is desirable when the rectifier circulating current is high.



Option#1: Synchronous rectifier

Figure 5 - Constant BIAS current source to improve Gate voltage

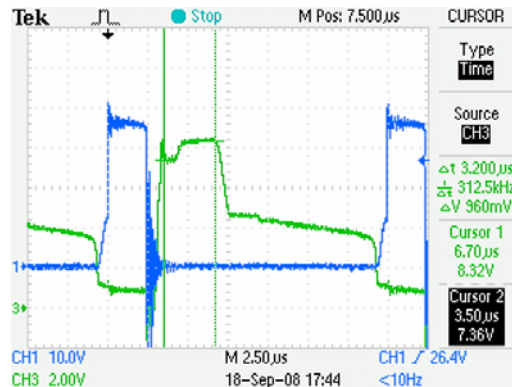

Figure 6 - Constant current source improves enhancement of low resistance MOSFET

In an ideal rectifier, there should be no power loss in the MOSFET, however, there is more than just low on resistance when creating an efficient rectifier. As light load and no load efficiency grow in importance, the gate driving loss becomes a serious factor. At low load, power loss within the synchronous rectifier comprises of losses associated with body diode conduction, MOSFET gate charge loss as well as the power consumed by the controller itself. The driving loss can be obtained from the product of switching frequency, gate charge value and Gate-Source voltage. The body diode turns on prior to the gate turn on in the synchronous rectifier. This enables zero voltage turn on of the MOSFET. Because of this sequence, there is no voltage across the synchronous switch during the turn on transition and the Miller effect is not present. Therefore, the effective gate charge can be approximated by the gate drain portion of gate charge, Q_{gd} subtracted from the total gate switching charge $Q_{g(tot)}$.

Another side effect in synchronous rectification is the MOSFET output capacitance C_{OSS} on the added synchronous MOSFET introduces a stray capacitance, which resonates with the transformer leakage inductance and leads to a larger voltage spike at turn off. To overcome this, use RC damping components in Figure 2 or redesign the transformer to reduce the voltage spike. Variation of operating frequency at full load could also be observed with the synchronous rectifier. The synchronous MOSFET capacitance is also reflected across the transformer and adds to the total output capacitance of the primary switch, therefore reducing the operating frequency from 67kHz to 60kHz. Nevertheless, this does not degrade performance of the synchronous rectifier compared with diode rectification.

High performance rectifier #2 - Super Barrier Rectifier™

The synchronous rectifier provides a significant efficiency improvement over a Schottky diode. However if the extra complexity of the synchronous rectifier is not desirable, the Super Barrier Rectifier™ (SBR™) can be used to give power supply designers an additional lever to improve the overall efficiency of their power supply design simply by replacing the output rectifying diodes. The key to the SBR™ technology lies in the patented structure with a MOS channel region formed under the thin gate oxide layer, Figure 7, where the “super” barrier for majority (electron) carriers is created without the unreliable Schottky contact.

The “super” barrier maintains a similar or better forward bias performance over Schottky but with higher reliability. Moreover, the SBR™ improves the reverse leakage performance. The potential barrier lowering due to the image charge, which is essential for the Schottky diode, is absent in SBR. The SBR reverse current is typical of a P-N diode, where reverse current consists of the constant injection and growing ionization currents. This improves thermal stability of the device at elevated temperature.

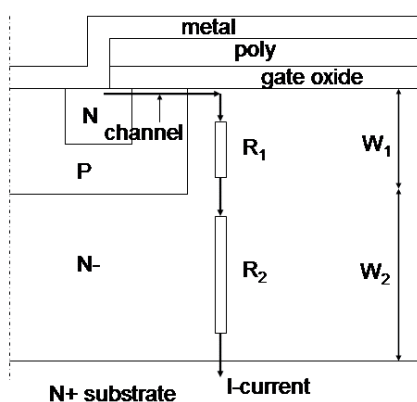

Figure 7 -

The Low VF SBR™ therefore has lower forward voltage than the competitive Schottky devices in the market, reducing the forward conduction losses of the output rectifiers and improving the auxiliary power supply efficiency.

Evaluation results

The test results for the server's standby power supply are shown in Figure 7. This particular design operates from the 400V PFC rail and provides three outputs at a continuous output power of 27W. The power supply efficiency with MBRB30H60CT as the output rectifier on the high current +5VSB output is 81.2% at 20% loading and it increases to 82.8% at full load.

DN94

As depicted by Figure 8, a synchronous MOSFET rectifier driven by ZXGD3101 drastically improves the power efficiency over Schottky diode. The efficiency improvement is affected by the loading condition and the improvement is between 2 to 3.5% at heavy load condition. The improvement is highly dependant on the synchronous MOSFET resistance. The larger efficiency improvement can be achieved with lower MOSFET $R_{DS(on)}$. At full load, the power supply efficiency with the 3.3 m Ω MOSFET is around 86%.

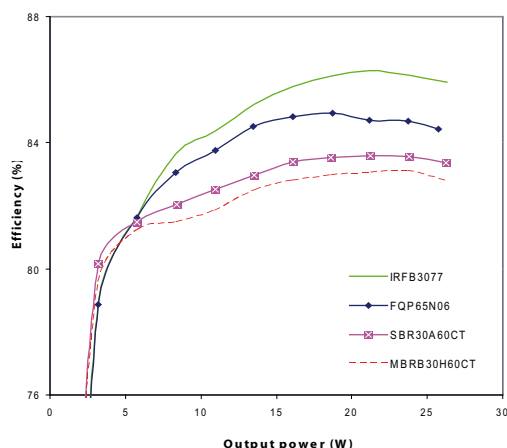

Figure 8 - Efficiency comparisons of various rectifiers

When replacing the MBRB30H60CT Schottky diodes with the Low VF SBR30A60CT diodes, the full load efficiency of the standby power supply improves from 82.8% to 83.3%. This is an efficiency improvement of over 0.5% compared to the Schottky diode. To enable the whole server power supply to achieve compliance with the Environment Protection Agency (EPA), Blue Angel and other low power system requirement, the +5VSB standby supply is typically required to have greater than 50% efficiency at 100mA load current on the +5VSB. The light load input supply power with the SBR rectifiers is 830mW which is similar to the Schottky diode.

As previously discussed, the capacitive gate charge and IC supply related losses dominate the conduction loss in the synchronous rectifier at light load. When replacing the Schottky diode with a MOSFET, the input power of the power supply at light load increases. To maintain 100mA load current, the measured input power of synchronous rectified power supply is 930mW or equivalent to 56% efficiency. This is a 100mW increase in power consumption compared to both SBR and Schottky solutions. Nevertheless, this is far out weighed by the significant conduction loss saving provided by synchronous rectification at nominal load.

Conclusion

With the new energy saving standards set by the EPA and the increasing adoption of the 80PLUS standard for server applications, the design of the standby converter within the server power supply is no longer trivial, but can be a very tough challenge for many power supply designers equipped with old Schottky technology. The ZXGD3101 synchronous rectifier controller and the low V_F SBR diodes can be used by designers as one of the tools to meet the new stringent efficiency requirements.

The experimental standby power supply manages to achieve a dramatic 3.5% efficiency improvement over the Schottky diodes when a 3.3m Ω $R_{DS(on)}$ synchronous MOSFET rectifier is used on the +5VSB output. The PC board could now be used to provide heat sinking, eliminating the need for external heat sink, and removing the cost of the heat sink and associated assembly costs. Alternatively, the low forward voltage SBR30A60CT enables designer to achieve 0.5% better efficiency than Schottky without making any major changes to their overall design. Snubber components may need to be fitted when using the SBR in Continuous Conduction Mode converter though to reduce EMI emission and filtering requirement.

Intentionally left blank

DN94

Definitions

Product change

Diodes Incorporated the right to alter, without notice, specifications, design, price or conditions of supply of any product or service. Customers are solely responsible for obtaining the latest relevant information before placing orders.

Applications disclaimer

The circuits in this design/application note are offered as design ideas. It is the responsibility of the user to ensure that the circuit is fit for the user's application and meets with the user's requirements. No representation or warranty is given and no liability whatsoever is assumed by Diodes Inc. with respect to the accuracy or use of such information, or infringement of patents or other intellectual property rights arising from such use or otherwise. Diodes Inc. does not assume any legal responsibility or will not be held legally liable (whether in contract, tort (including negligence), breach of statutory duty, restriction or otherwise) for any damages, loss of profit, business, contract, opportunity or consequential loss in the use of these circuit applications, under any circumstances.

Life support

Diodes Zetex products are specifically not authorized for use as critical components in life support devices or systems without the express written approval of the Chief Executive Officer of Diodes Incorporated. As used herein:

A. Life support devices or systems are devices or systems which:

1. are intended to implant into the body

or

2. support or sustain life and whose failure to perform when properly used in accordance with instructions for use provided in the labelling can be reasonably expected to result in significant injury to the user.

B. A critical component is any component in a life support device or system whose failure to perform can be reasonably expected to cause the failure of the life support device or to affect its safety or effectiveness.

Reproduction

The product specifications contained in this publication are issued to provide outline information only which (unless agreed by the company in writing) may not be used, applied or reproduced for any purpose or form part of any order or contract or be regarded as a representation relating to the products or services concerned.

Terms and Conditions

All products are sold subjects to Diodes Inc. terms and conditions of sale, and this disclaimer (save in the event of a conflict between the two when the terms of the contract shall prevail) according to region, supplied at the time of order acknowledgement.

For the latest information on technology, delivery terms and conditions and prices, please contact your nearest Diodes' sales office .

Quality of product

Diodes Zetex Semiconductors Limited is an ISO 9001 and TS16949 certified semiconductor manufacturer.

To ensure quality of service and products we strongly advise the purchase of parts directly from Diodes Inc. or one of our regionally authorized distributors. For a complete listing of authorized distributors please visit: www.diodes.com

Diodes Zetex does not warrant or accept any liability whatsoever in respect of any parts purchased through unauthorized sales channels.

ESD (Electrostatic discharge)

Semiconductor devices are susceptible to damage by ESD. Suitable precautions should be taken when handling and transporting devices. The possible damage to devices depends on the circumstances of the handling and transporting, and the nature of the device. The extent of damage can vary from immediate functional or parametric malfunction to degradation of function or performance in use over time. Devices suspected of being affected should be replaced.

Green compliance

Diodes Zetex Semiconductors is committed to environmental excellence in all aspects of its operations which includes meeting or exceeding regulatory requirements with respect to the use of hazardous substances. Numerous successful programs have been implemented to reduce the use of hazardous substances and/or emissions.

All Diodes Zetex components are compliant with the RoHS directive, and through this it is supporting its customers in their compliance with WEEE and ELV directives.

Product status key:

"Preview"	Future device intended for production at some point. Samples may be available
"Active"	Product status recommended for new designs
"Last time buy (LTB)"	Device will be discontinued and last time buy period and delivery is in effect
"Not recommended for new designs"	Device is still in production to support existing designs and production
"Obsolete"	Production has been discontinued

Datasheet status key:

"Draft version"	This term denotes a very early datasheet version and contains highly provisional information, which may change in any manner without notice.
"Provisional version"	This term denotes a pre-release datasheet. It provides a clear indication of anticipated performance. However, changes to the test conditions and specifications may occur, at any time and without notice.
"Issue"	This term denotes an issued datasheet containing finalized specifications. However, changes to specifications may occur, at any time and without notice.

Sales offices

The Americas	Europe	Taiwan	Shanghai	Shenzhen	Korea
3050 E. Hillcrest Drive Westlake Village, CA 91362-3154 Tel: (+1) 805 446 4800 Fax: (+1) 805 446 4850	Kustermann-Park Balanstraße 59, D-81541 München Germany Tel: (+49) 894 549 490 Fax: (+49) 894 549 4949	7F, No. 50, Min Chuan Road Hsin-Tien Taipei, Taiwan Tel: (+886) 289 146 000 Fax: (+886) 289 146 639	Rm. 606, No.1158 Changning Road Shanghai, China Tel: (+86) 215 241 4882 Fax (+86) 215 241 4891	ANLIAN Plaza, #4018 Jintian Road Futian CBD, Shenzhen, China Tel: (+86) 755 882 849 88 Fax: (+86) 755 882 849 99	6 Floor, Changhwa B/D, 1005-5 Yeongtong-dong, Yeongtong-gu, Suwon-si, Gyeonggi-do, Korea 443-813 Tel: (+82) 312 731 884 Fax: (+82) 312 731 885