

General Description

The AL8866Q is a Buck-Boost, Boost, Buck, and SEPIC (single-ended primary-inductance converter) DC-switching controller designed to drive an external MOSFET for high-power automotive LED applications. The AL8866Q operates within a wide input power supply range of 4.5V to 85V.

The AL8866Q is based on a fixed-frequency, peak current-mode control architecture to incorporate spread spectrum frequency modulation technique, achieving low-EMI performance.

The AL8866Q modulates the LED current with analog or PWM dimming techniques. Analog dimming responses with over 100:1 linear range is obtained by varying the voltage at the DIM pin. PWM dimming is achieved by directly modulating the same DIM pin with the desired duty cycle.

The AL8866Q integrates soft-start function, which limits the current through the inductor and external power switch during initialization start up. It gradually increases the inductor and switch current to minimize potential overvoltage and overcurrent at the output.

The AL8866Q, with an open-drain fault output, indicates when protection conditions trigger, such as LED output overvoltage, LED output open/short, cycle-by-cycle overcurrent protection, sense resistor and inductor/diode shorts, diode open, and thermal shutdown.

The AL8866Q is available in the enhanced thermal SO-8EP and wettable U-DFN3030-10 packages. The demo board uses a DFN package.

Applications

- Automotive front lighting
- Automotive high beams, low beams
- Automotive daytime running lights
- Automotive fog lights, turn lights, and position lights
- Other automotive LED lighting

Key Features

- AEC-Q100 (Grade 1) Qualified
- Wide Input Voltage Range from 4.5V to 85V
- Pre-Fixed 400kHz Switching Frequency (Factory Set)
- Spread Spectrum Frequency Modulation for Low EMI
- Analog Dimming Range: 1% to 100%
- 100% Dimming Level $\pm 3\%$ Current Accuracy
- 20% Dimming Level $\pm 12\%$ Current Accuracy
- PWM Dimming Ratio 100:1 at 200Hz PWM Frequency
- Programmable Soft Start
- Fault Status Indicator for Protections
- Output Overvoltage and LED Open Circuit Protection
- Output Undervoltage and LED Short Circuit Protection
- Cycle-by-Cycle Overcurrent Limitation Protection
- Sense resistor Shorted Circuit Protection
- Diode/Inductor Shorted Circuit Protection
- Diode Open Circuit Protection
- Thermal Shutdown

AL8866QE2 Specifications

Parameter	Value
Input Voltage	9VDC to 16VDC
LED Current	1A
Number of LEDs	1~7pcs
XY Dimension	113mm x 58mm



Figure 1: Top View

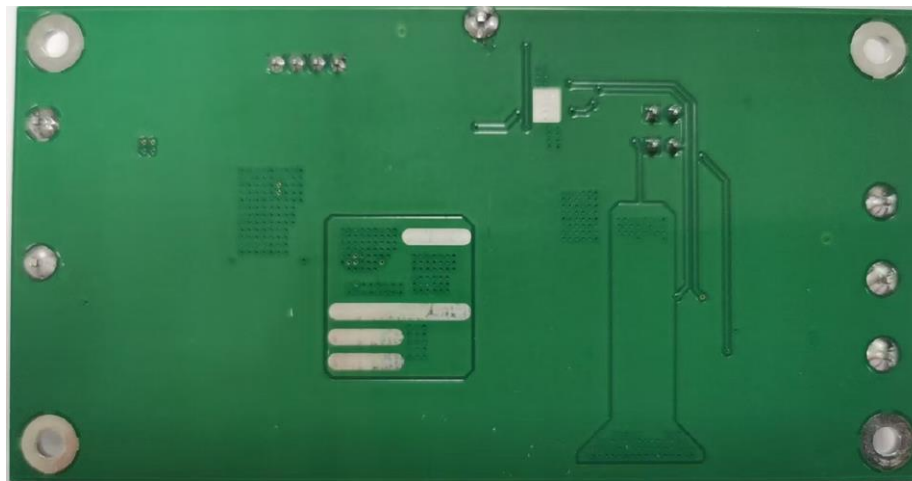

Figure 2: Bottom View

Connection Instructions & Quick Start Guide

1. Ensure that the DC source is switched OFF or disconnected before soldering or connecting.
2. By default, the LED current of the evaluation board is preset at 1000mA output.
3. Connect the anode wire of the external LED string to the LEDA connector.
4. Connect the cathode wire of the external LED string to the LEDK2 connector for Boost applications; LEDK1 connector for Buck-Boost applications. This Demo Board, by default, uses buck-boost topology by shorting R23, R24. Shorting R25, R26 are optional for boost applications.
5. Power Supply Input: 9~16VDC between **VIN+** and **GND**.
6. For optional Boost applications, OVP protection is obtained by the jumper shorting the J2 connector. Buck-Boost OVP by the jumper shorting J3 by default. J1 is a common GND for prompt testing.
7. Ensure that the area around the board is clear and safe. The board and LEDs are preferably enclosed in a transparent safety cover.
8. Turn on the main switch. The LED string should light up.

Evaluation Board Schematic

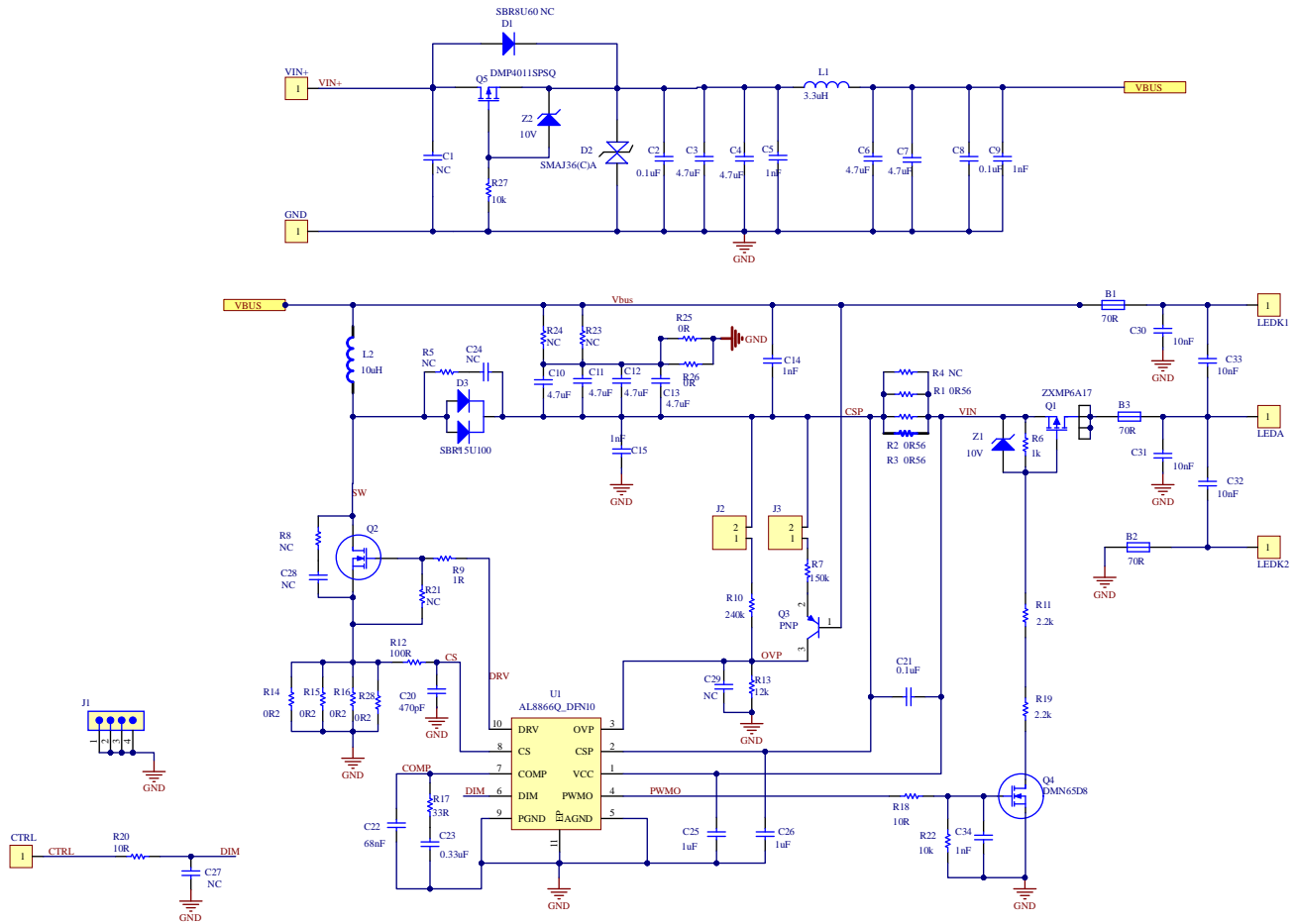

Figure 3: Evaluation Board Schematic

Evaluation Board Layout

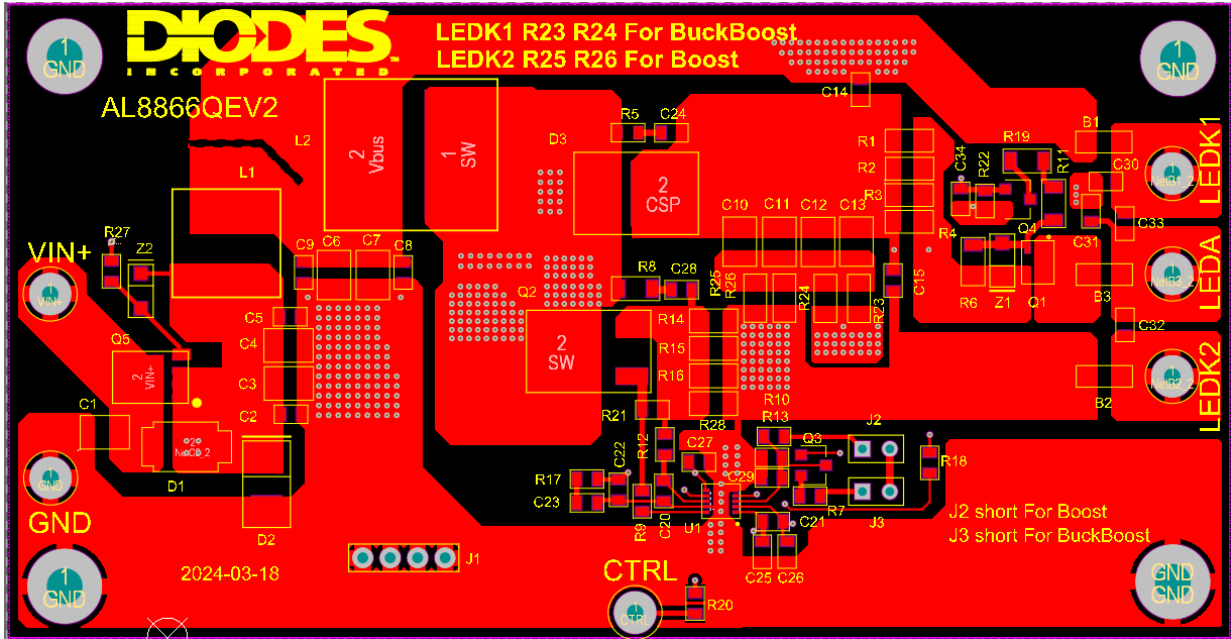

Figure 4: PCB Layout Top Layer View

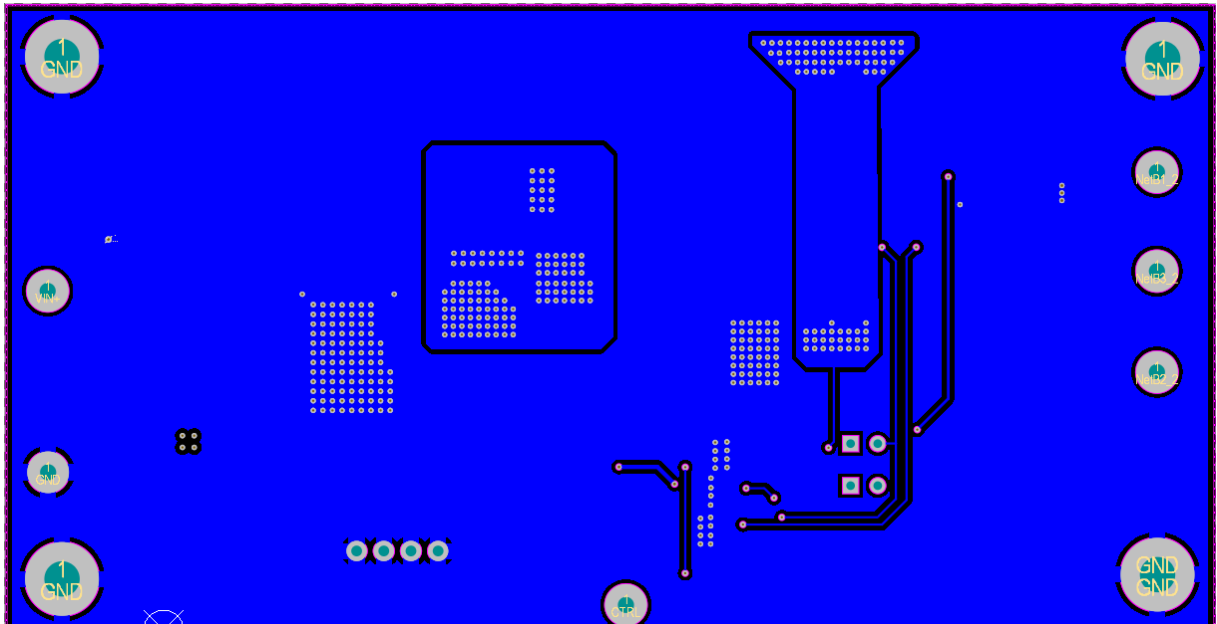

Figure 5: PCB Layout Bottom Layer View

Bill of Materials

No.	Designator	Description	Quantity
1	C2, C8, C21	Cap, X7R, 100nF, 50V, 0805,	3
2	C3, C4, C6, C7, C10, C11, C12, C13	Cap, X7R, 4.7uF, 100V, 1210,	8
3	C5, C9, C14, C15	Cap, X7R, 1nF, 50V, 0805,	4
4	C30, C31, C32, C33	Cap, X7R, 10nF, 50V, 0805,	4
5	C20	Cap, X7R, 470pF, 50V, 0805,	1
6	C22	Cap, X7R, 68nF, 50V, 0805,	1
7	C23	Cap, X7R, 330nF, 50V, 0805,	1
8	C25, C26	Cap, X7R, 1uF, 50V, 0805,	2
9	R1	Resistor 0R62 1% 1206	1
10	R2, R3	Resistor 0R56 1% 1206	2
11	R14, R15, R16,	Resistor 0R15 1% 1/2W 1206	3
12	R23, R24	Resistor 0R 1% 1206	2
13	R6	Resistor 1k 1% 1206	1
14	R11, R19	Resistor 2.2k 1% 1206	2
15	R7	Resistor 150k 1% 0805	1
16	R10	Resistor 240k 1% 0805	1
17	R13	Resistor 12k 1% 0805	1
18	R21, R22, R27	Resistor 10k 1% 0805	3
19	R9	Resistor 1R 1% 0805	1
20	R12	Resistor 100R 1% 0805	1
21	R17	Resistor 33R 1% 0805	1
22	R18 R20	Resistor 10R 1% 0805	2
23	VIN+, LEDA,	Connector, Red color	2
24	GND, LEDK1, LEDK2,	Connector, Black color	3
25	CTRL,	Connector, Yellow color	1
26	D2	Diode TVS SMAJ36CA 36V SMB DIODES	1
27	D3	Diode SBR15U100CTLQ DPAK DIODES	1
28	Z1 Z2	Diode BZT52C10Q 10V SOD123 DIODES	2
29	J1	Connector_4PIN_2.54mm	1
30	J2, J3	Connector_2PIN_2.54mm	2
31	J3,	Jumper for CON J3	1
32	B1, B2, B3	BeadCore,70R 2.5A 74279215, WURTH	3
33	L1	Inductor SMD 3.3uH 12A, 784325033, WURTH	1
34	L2	Inductor SMD 10uH 8.8A 744373965100, WURTH	1
35	Q1	P-MOS, ZXMP6A17E6Q 60V 3A SOT26,DIODES	1
36	Q2	N-MOS, DMTH10H015SK3Q DPAK DIODES	1
37	Q3	TR PNP ZXTP5401FLQ SOT23 DIODES	1
38	Q4	N-MOS, DMN65D8LQ 60V 0.3A SOT23 DIODES	1
39	Q5	P-MOS, DMP4011SPSQ,DI5060 DIODES	1
40	U1	IC AL8866QFN-7 DIODES	1
41	PCB	PCB FR4 2sides, 1.6mm 2OZ,113X58.6mm	1

Efficiency Test

Input(V)	Iin(A)	Pin(W)	Io(A)	Vo(V)	Po(W)	Eff(%)
9.0	2.605	23.45	1.002	20.32	20.36	86.8
10.0	2.331	23.31	1.002	20.33	20.37	87.4
11.0	2.108	23.19	1.001	20.32	20.34	87.7
12.0	1.934	23.21	1.000	20.33	20.33	87.6
13.0	1.780	23.14	1.000	20.27	20.27	87.6
14.0	1.655	23.17	1.000	20.31	20.31	87.7
15.0	1.548	23.22	1.000	20.30	20.30	87.4
16.0	1.450	23.20	1.000	20.29	20.29	87.5

Dimming Curve

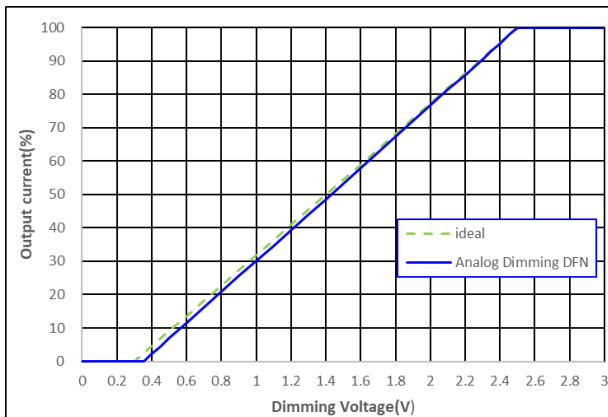

Analog Dimming

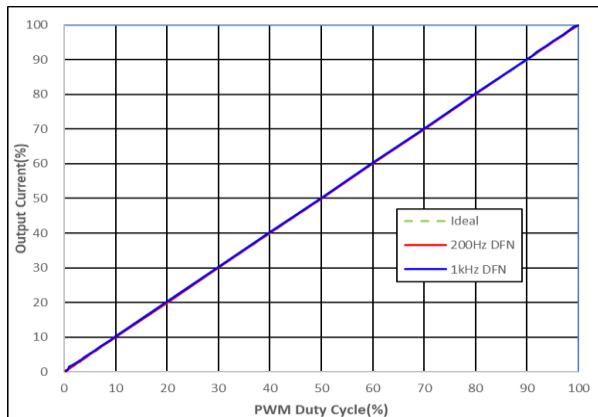

PWM Dimming

Operating Waveforms

Turn On & Off by Vin, Buck-Boost, Test condition: VIN=12V, Io=1A Vo=21V

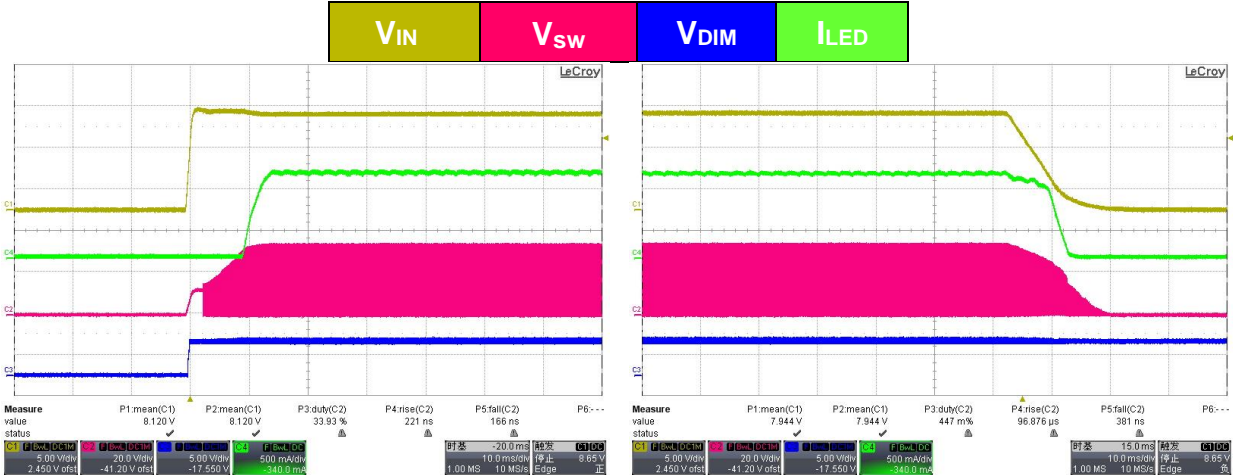

Figure 6 Turn on @ DIM Floating

Figure 7 Turn off @ DIM Floating

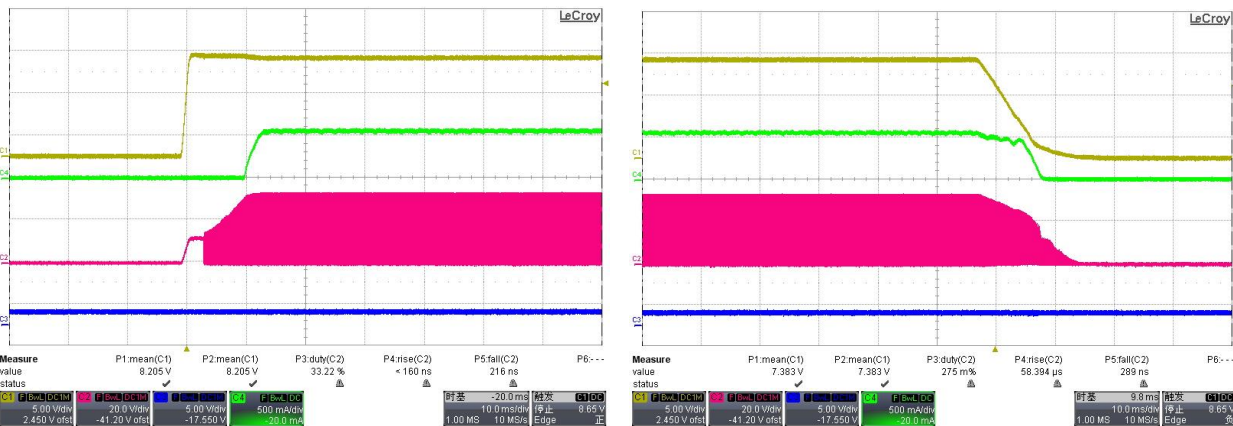

Figure 8 Turn on @ADim = 1.5V

Figure 9 Turn off @ ADim= 1.5V

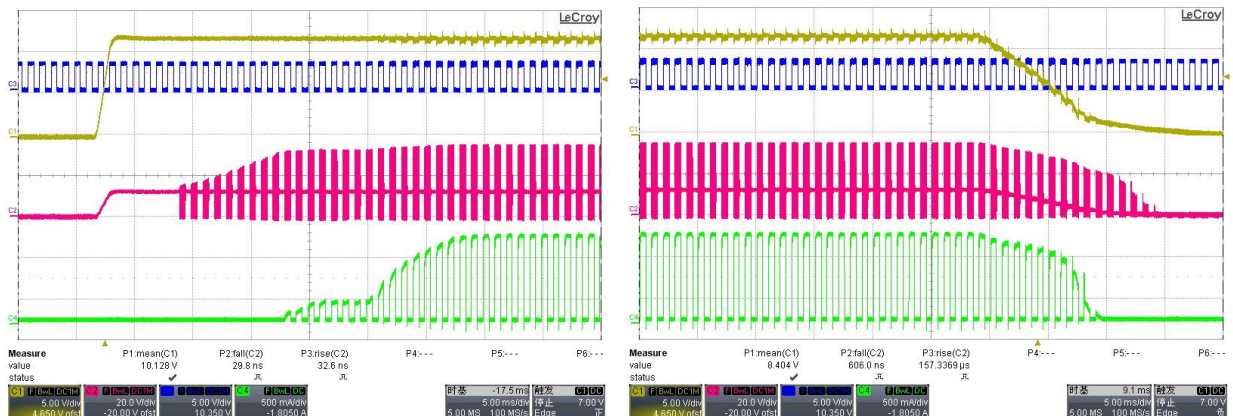

Figure 10 Turn on @ PWM=50% 1kHz

Figure 11 Turn off @ PWM=50% 1kHz

Operating Waveforms (continued)

Stable Operating, Buck-Boost, $V_{IN}=12V$, $I_o=1A$ $V_o=21V$

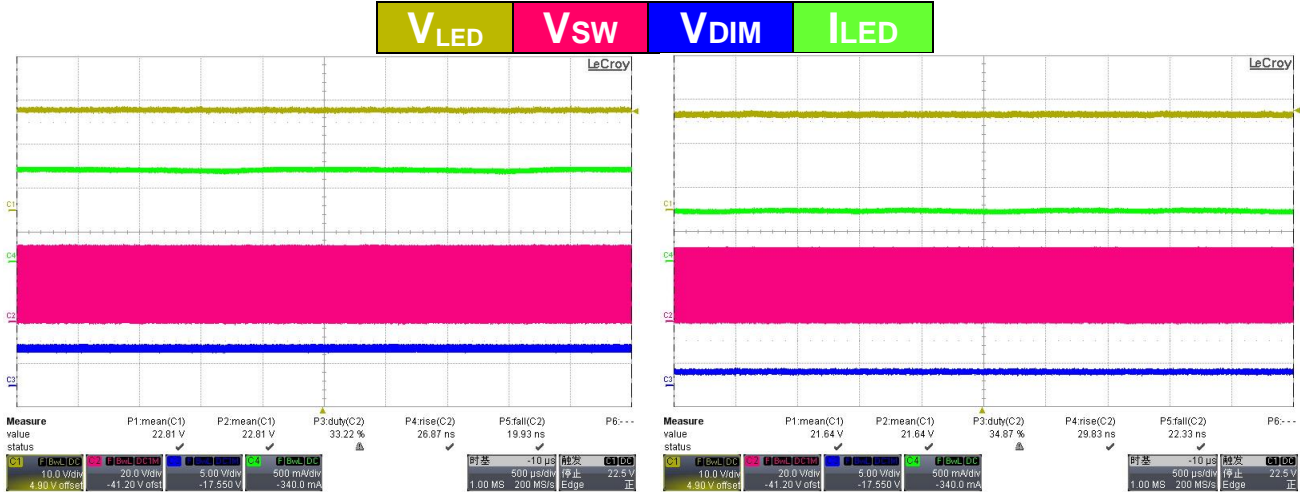

Figure 12 Stable waveform at Dim Float

Figure 13 Stable waveform at Dim=1.5V

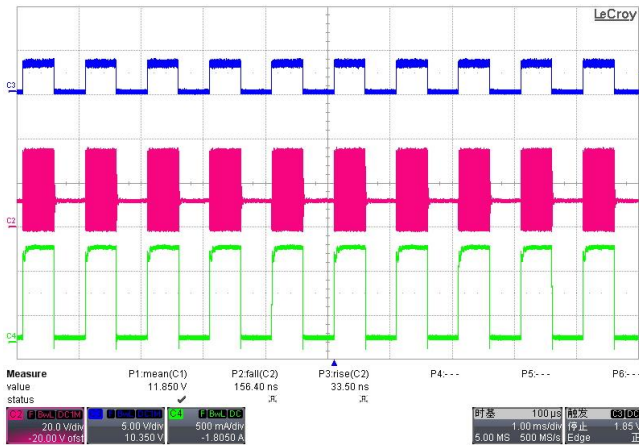

Figure 14 PWM Dimming at 1kHz 50%

IMPORTANT NOTICE

1. DIODES INCORPORATED (Diodes) AND ITS SUBSIDIARIES MAKE NO WARRANTY OF ANY KIND, EXPRESS OR IMPLIED, WITH REGARDS TO ANY INFORMATION CONTAINED IN THIS DOCUMENT, INCLUDING, BUT NOT LIMITED TO, THE IMPLIED WARRANTIES OF MERCHANTABILITY, FITNESS FOR A PARTICULAR PURPOSE OR NON-INFRINGEMENT OF THIRD PARTY INTELLECTUAL PROPERTY RIGHTS (AND THEIR EQUIVALENTS UNDER THE LAWS OF ANY JURISDICTION).
2. The Information contained herein is for informational purpose only and is provided only to illustrate the operation of Diodes' products described herein and application examples. Diodes does not assume any liability arising out of the application or use of this document or any product described herein. This document is intended for skilled and technically trained engineering customers and users who design with Diodes' products. Diodes' products may be used to facilitate safety-related applications; however, in all instances customers and users are responsible for (a) selecting the appropriate Diodes products for their applications, (b) evaluating the suitability of Diodes' products for their intended applications, (c) ensuring their applications, which incorporate Diodes' products, comply the applicable legal and regulatory requirements as well as safety and functional-safety related standards, and (d) ensuring they design with appropriate safeguards (including testing, validation, quality control techniques, redundancy, malfunction prevention, and appropriate treatment for aging degradation) to minimize the risks associated with their applications.
3. Diodes assumes no liability for any application-related information, support, assistance or feedback that may be provided by Diodes from time to time. Any customer or user of this document or products described herein will assume all risks and liabilities associated with such use, and will hold Diodes and all companies whose products are represented herein or on Diodes' websites, harmless against all damages and liabilities.
4. Products described herein may be covered by one or more United States, international or foreign patents and pending patent applications. Product names and markings noted herein may also be covered by one or more United States, international or foreign trademarks and trademark applications. Diodes does not convey any license under any of its intellectual property rights or the rights of any third parties (including third parties whose products and services may be described in this document or on Diodes' website) under this document.
5. Diodes' products are provided subject to Diodes' Standard Terms and Conditions of Sale (<https://www.diodes.com/about/company/terms-and-conditions/terms-and-conditions-of-sales/>) or other applicable terms. This document does not alter or expand the applicable warranties provided by Diodes. Diodes does not warrant or accept any liability whatsoever in respect of any products purchased through unauthorized sales channel.
6. Diodes' products and technology may not be used for or incorporated into any products or systems whose manufacture, use or sale is prohibited under any applicable laws and regulations. Should customers or users use Diodes' products in contravention of any applicable laws or regulations, or for any unintended or unauthorized application, customers and users will (a) be solely responsible for any damages, losses or penalties arising in connection therewith or as a result thereof, and (b) indemnify and hold Diodes and its representatives and agents harmless against any and all claims, damages, expenses, and attorney fees arising out of, directly or indirectly, any claim relating to any noncompliance with the applicable laws and regulations, as well as any unintended or unauthorized application.
7. While efforts have been made to ensure the information contained in this document is accurate, complete and current, it may contain technical inaccuracies, omissions and typographical errors. Diodes does not warrant that information contained in this document is error-free and Diodes is under no obligation to update or otherwise correct this information. Notwithstanding the foregoing, Diodes reserves the right to make modifications, enhancements, improvements, corrections or other changes without further notice to this document and any product described herein. This document is written in English but may be translated into multiple languages for reference. Only the English version of this document is the final and determinative format released by Diodes.
8. Any unauthorized copying, modification, distribution, transmission, display or other use of this document (or any portion hereof) is prohibited. Diodes assumes no responsibility for any losses incurred by the customers or users or any third parties arising from any such unauthorized use.
9. This Notice may be periodically updated with the most recent version available at <https://www.diodes.com/about/company/terms-and-conditions/important-notice>

The Diodes logo is a registered trademark of Diodes Incorporated in the United States and other countries.

All other trademarks are the property of their respective owners

© 2024 Diodes Incorporated. All Rights Reserved.

www.diodes.com