

Description

The AH921 is a Hall-effect latch designed in mixed signal CMOS technology. It is quite suitable for use in automotive, industrial and consumer applications.

Superior high-temperature performance is made possible through dynamic offset cancellation, which reduces the residual offset voltage normally caused by device over-molding, temperature dependencies, and thermal stress. The device integrates a voltage regulator, Hall-voltage generator, small-signal amplifier, chopper stabilization, schmitt trigger, and is directly drivable by the output.

An on-board regulator permits operation with supply voltage from 3.5V to 24V.

The AH921 is available in TO-92S-3 and SOT-23-3 packages, which are optimized for most applications.

Features

- Wide Operating Voltage Range from 3.5V to 24V
- Symmetrical Switch Points
- Chopper-stabilized Amplifier Stage
- Superior Temperature Stability
- Compact Size
- Built-in Pull-up Resistor
- Wide Operating Temperature Range: -40°C to +125°C
- ESD Rating: 3500V (Human Body Model)
- **Totally Lead-free & Fully RoHS Compliant (Note 1 & 2)**
- **Halogen and Antimony Free. "Green" Device (Note 3)**
- **For automotive applications requiring specific change control (i.e. parts qualified to AEC-Q100/101/200, PPAP capable, and manufactured in IATF 16949 certified facilities), please [contact us](#) or your local Diodes representative. <https://www.diodes.com/quality/product-definitions/>**

Notes:

1. No purposely added lead. Fully EU Directive 2002/95/EC (RoHS), 2011/65/EU (RoHS 2) & 2015/863/EU (RoHS 3) compliant.
2. See <https://www.diodes.com/quality/lead-free/> for more information about Diodes Incorporated's definitions of Halogen- and Antimony-free, "Green" and Lead-free.
3. Halogen- and Antimony-free "Green" products are defined as those which contain <900ppm bromine, <900ppm chlorine (<1500ppm total Br + Cl) and <1000ppm antimony compounds.

Pin Assignments

(Front View)

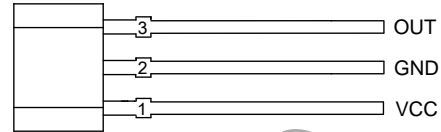

TO-92S-3

(Top View)

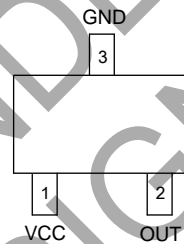

SOT-23-3

Applications

- Brushless DC Motor Commutation
- Brushless DC Fan
- Solid-state Switch
- Revolution Counting
- Speed Detection
- High Sensitivity and Unconnected Switch

Typical Applications Circuit

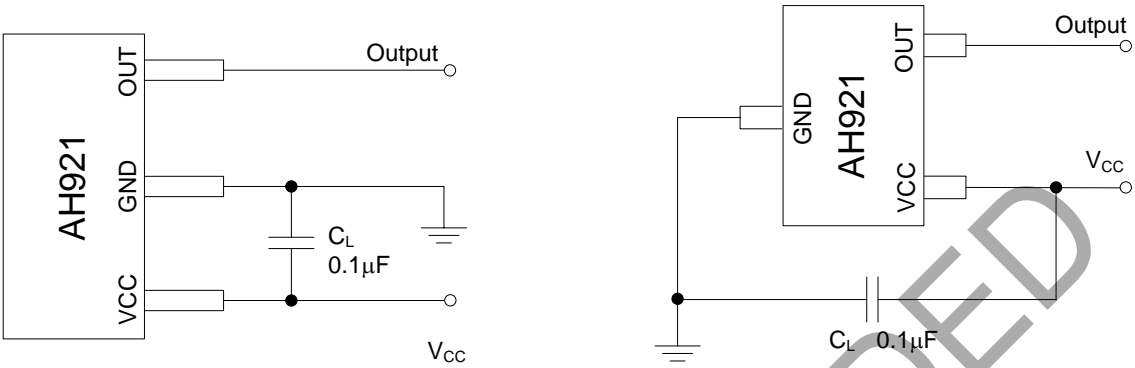

Pin Descriptions

Pin Number		Pin Name	Function
TO-92S-3	SOT-23-3		
1	1	VCC	Supply voltage
2	3	GND	Ground pin
3	2	OUT	Output Pin

Functional Block Diagram

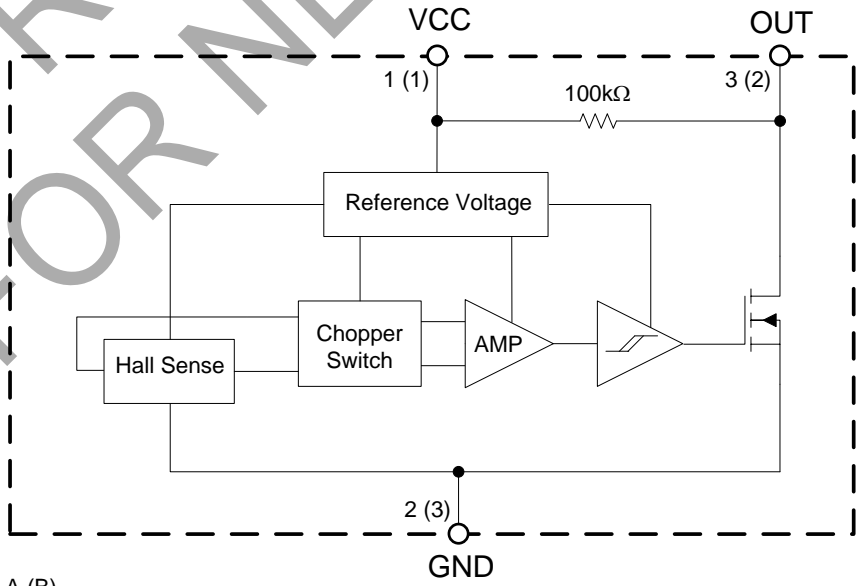

A (B)
A for TO-92S-3
B for SOT-23-3

Absolute Maximum Ratings (Note 4)

Symbol	Parameter	Rating		Unit
V_{CC}	Supply Voltage	28		V
I_{CC}	Supply Current (Fault)	5		mA
I_{OUT}	Output Current (Continuous)	25		mA
P_D	Power Dissipation	TO-92S-3	400	mW
		SOT-23-3	230	
T_A	Operating Temperature	-50 to +150		°C
T_{STG}	Storage Temperature	-65 to +150		°C
T_J (Max)	Maximum Junction Temperature	+165		°C
ESD	ESD (Human Body Model)	3500		V

Note: 4. Stresses greater than those listed under *Absolute Maximum Ratings* can cause permanent damage to the device. These are stress ratings only, and functional operation of the device at these or any other conditions beyond those indicated under *Recommended Operating Conditions* is not implied. Exposure to *Absolute Maximum Ratings* for extended periods can affect device reliability.

Recommended Operating Conditions

Symbol	Parameter	Min	Max	Unit
V_{CC}	Supply Voltage	3.5	24	V
T_A	Operating Temperature	-40	+125	°C

Electrical Characteristics (@ $V_{CC}=12V$, $T_A=+25^{\circ}C$, unless otherwise specified. Notes 5 & 6.)

Symbol	Parameter	Conditions	Min	Typ	Max	Unit
V_{CC}	Supply Voltage	Operating	3.5	12	24	V
I_{CC}	Supply Current	$B < B_{RP}$	-	3.0	5.0	mA
		$B > B_{OP}$	-	3.0	5.0	
V_{SAT}	Saturation Voltage	$V_{CC}=3.5V$, $I_{OUT}=5mA$, $B > B_{OP}$ (Note 7)	-	50	120	mV
		$I_{OUT}=20mA$, $B > B_{OP}$ (Note 7)	-	185	500	
		$V_{CC}=24V$, $I_{OUT}=20mA$, $B > B_{OP}$ (Note 7)	-	185	500	
$I_{LEAKAGE}$	Output Leakage Current	$V_{CC}=V_{OUT}=24V$, $B < B_{RP}$ (Note 8)	-	0.1	10	μA
t_{RISING}	Output Rising Time	$C_L=20pF$	-	0.4	2	μs
$t_{FALLING}$	Output Falling Time	$C_L=20pF$	-	0.4	2	μs

- Notes: 5. Output initial status is low when powering on.
 6. The supply current I_{CC} represents the average supply current. The output is open during measurement.
 7. The device is put under the magnetic field: $B > B_{OP}$.
 8. The device is put under the magnetic field: $B < B_{RP}$.

Magnetic Characteristics (@ $V_{CC}=12V$, $T_A=+25^{\circ}C$, unless otherwise specified.)

Symbol	Parameter	Min	Typ	Max	Unit
B_{OP}	Operating Point	5	22	40	Gauss
B_{RP}	Releasing Point	-40	-22	-5	Gauss
B_{HYS}	Hysteresis	-	45	-	Gauss

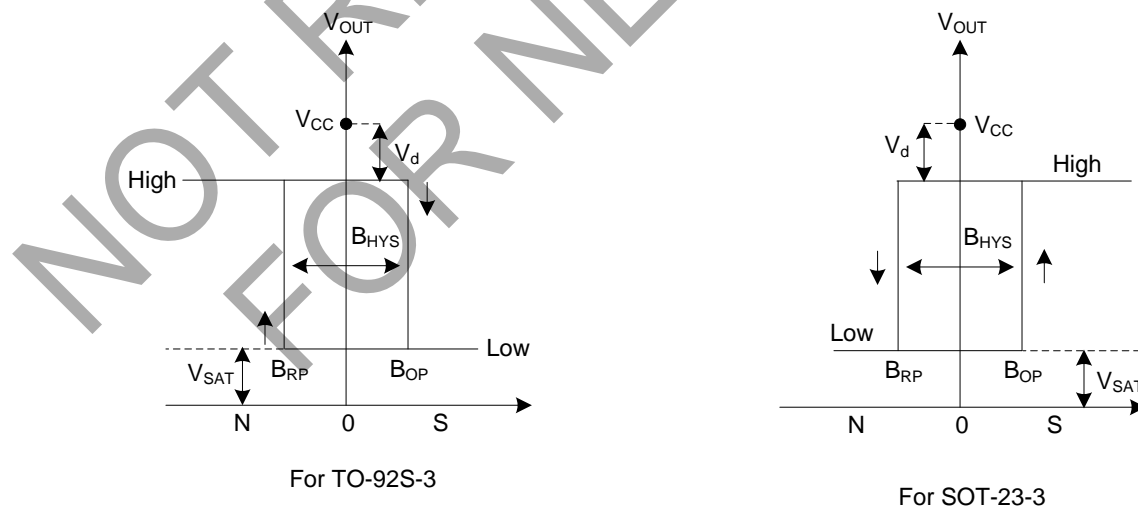

Figure 1. Magnetic Flux Density of AH921

Magnetic Characteristics (Continued)

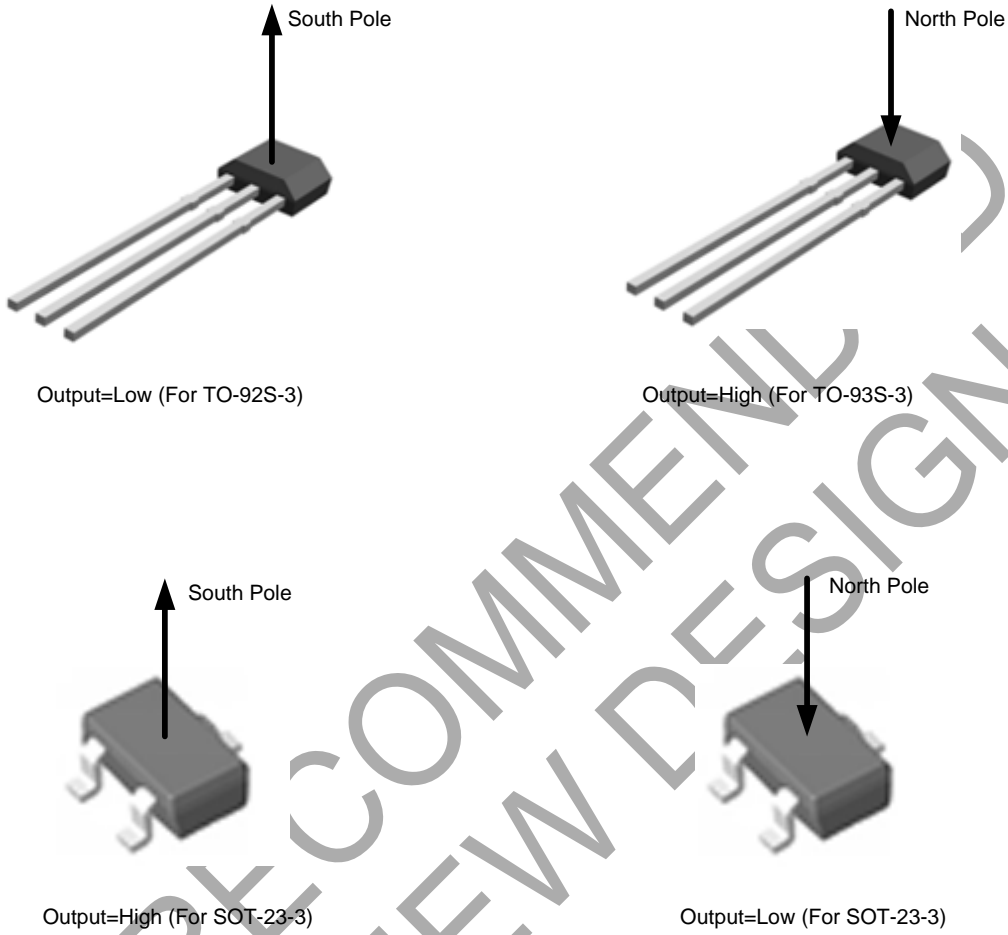

Figure 2. Output Status vs. Magnetic Pole

Package Type	Parameter	Test Condition	Output
TO-92S-3	South Pole	$B > B_{OP}$	Low
	North Pole	$B < B_{RP}$	High
SOT-23-3	South Pole	$B > B_{OP}$	High
	North Pole	$B < B_{RP}$	Low

Table 1. Output Status vs. Magnetic Pole

Magnetic Characteristics (Continued)

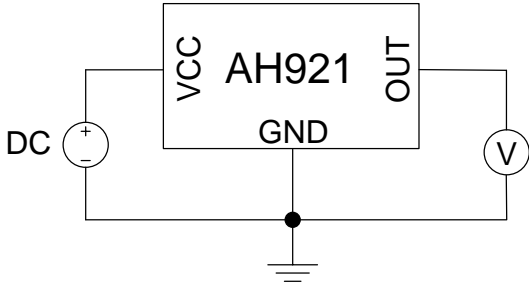

Figure 3. Magnetic Thresholds

Test Circuit and Test Conditions

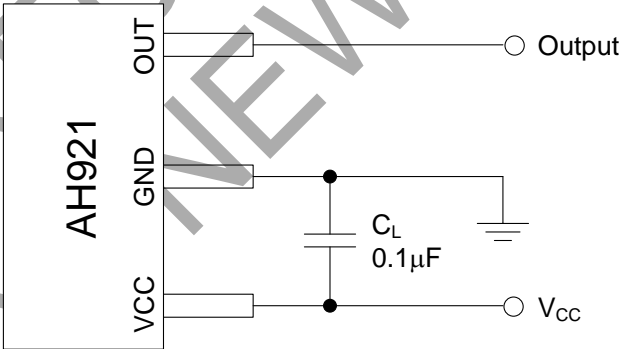

Figure 4. Test Circuit of AH921

Test Circuit and Test Conditions (Continued)

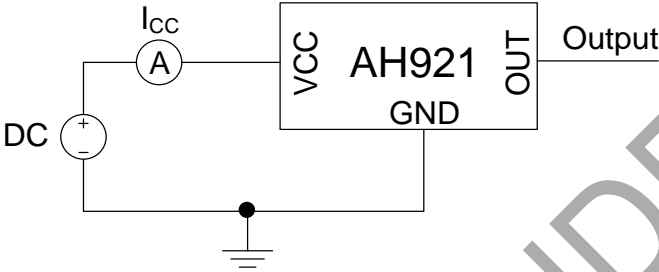

Figure 5. Test Condition of AH921 (Supply Current)

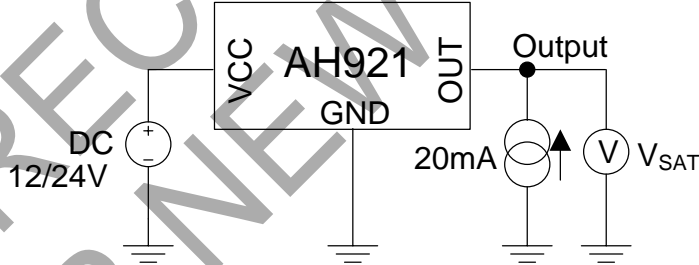

Figure 6. Test Condition of AH921 (Output Saturation Voltage)

Test Circuit and Test Conditions (Continued)

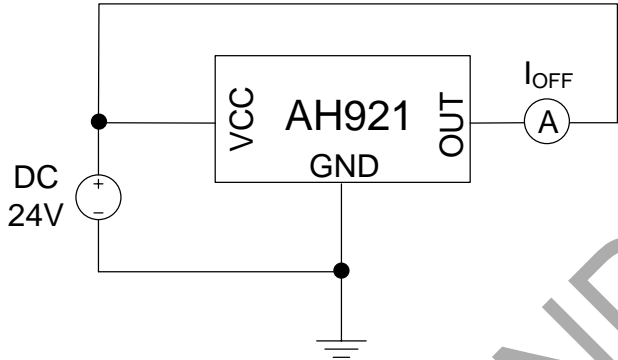
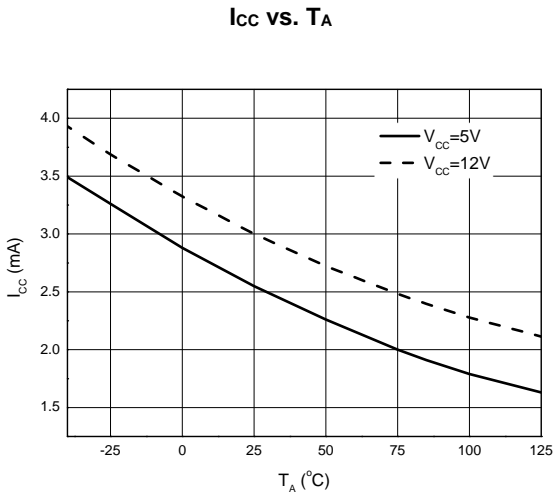
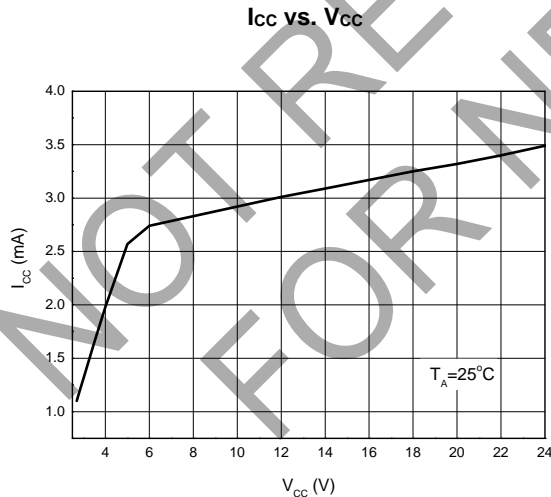

Figure 7. Test Condition of AH921 (Output Leakage Current)

Performance Characteristics



Performance Characteristics (Continued)

B_{OP}/B_{RP}/B_{HYS} VS. V_{CC}

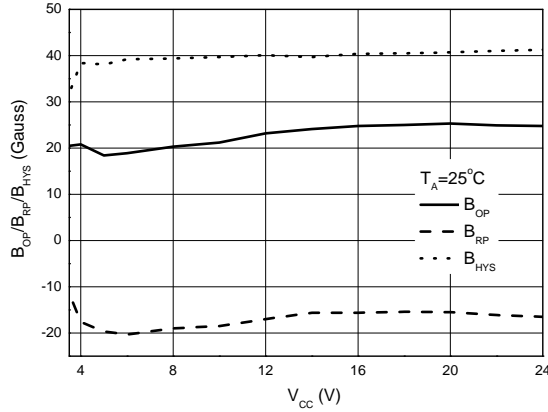

B_{OP}/B_{RP}/B_{HYS} VS. T_A

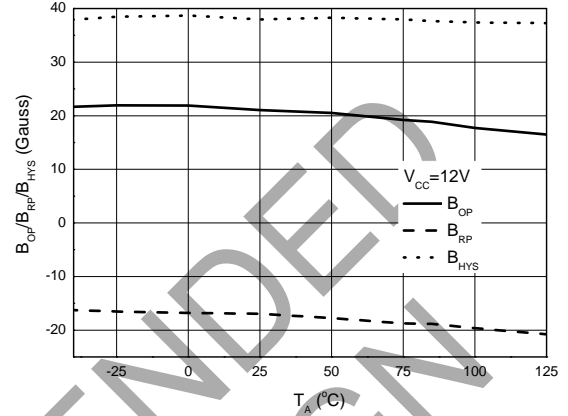

V_{SAT} VS. I_{OUT}

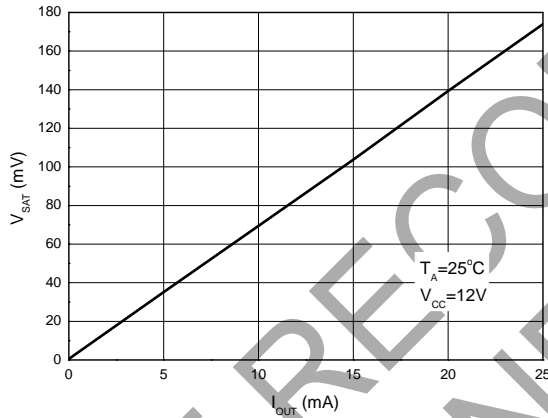

V_{SAT} VS. T_A

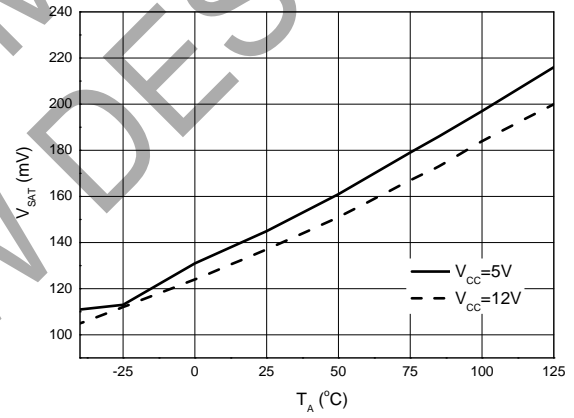

P_D VS. T_A

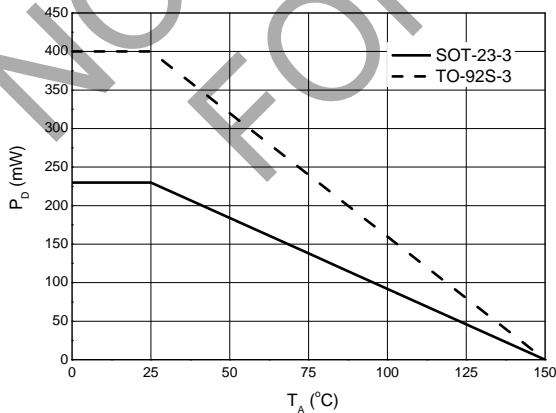

Ordering Information

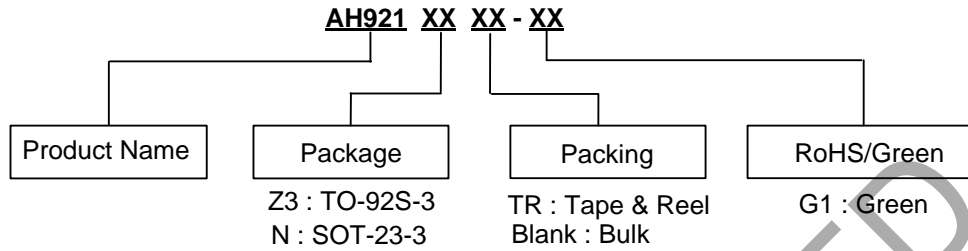

Device	Status(Note 9)	Package Code	Packaging	Bulk	7" Tape and Reel
				Quantity	Quantity
AH921Z3-G1	NRND	Z3	TO-92S-3	1000/Bulk	NA
AH921NTR-G1	NRND	N	SOT-23-3	NA	3000/Tape & Reel

Note 9: NRND = Not Recommended for New Design.

Marking Information

(1) Package Type: TO-92S-3

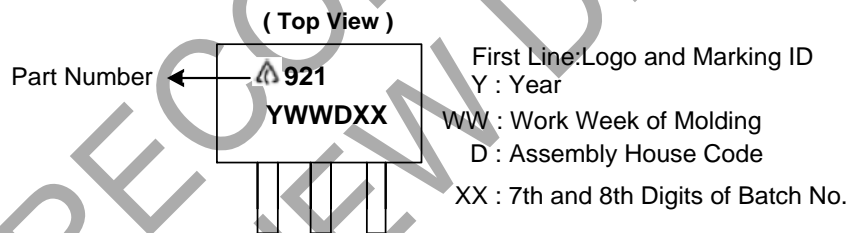

Part Number	Package	Identification Code
AH921	TO-92S-3	921

(2) Package Type: SOT-23-3

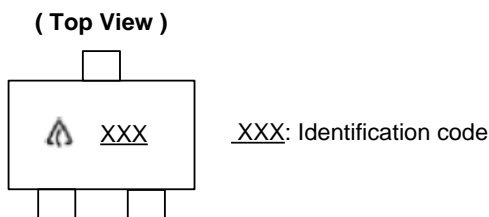

Part Number	Package	Identification Code
AH921	SOT-23-3	GS6

Package Outline Dimensions (All dimensions in mm(inch).)

Please see <http://www.diodes.com/package-outlines.html> for the latest version.

(1) Package Type: TO-92S-3

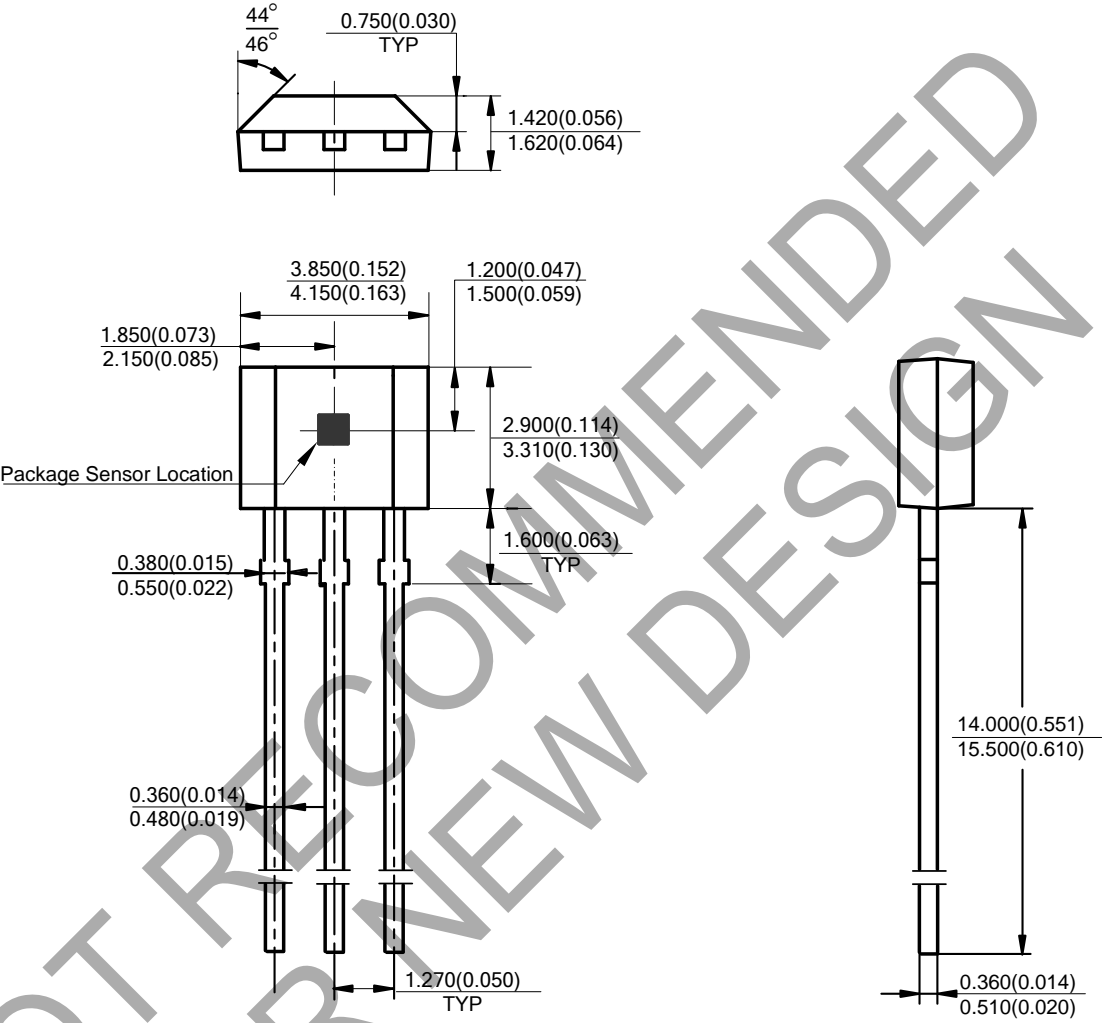

Package Outline Dimensions (All dimensions in mm (inch) (Continued))

Please see <http://www.diodes.com/package-outlines.html> for the latest version.

(2) Package Type: SOT-23-3

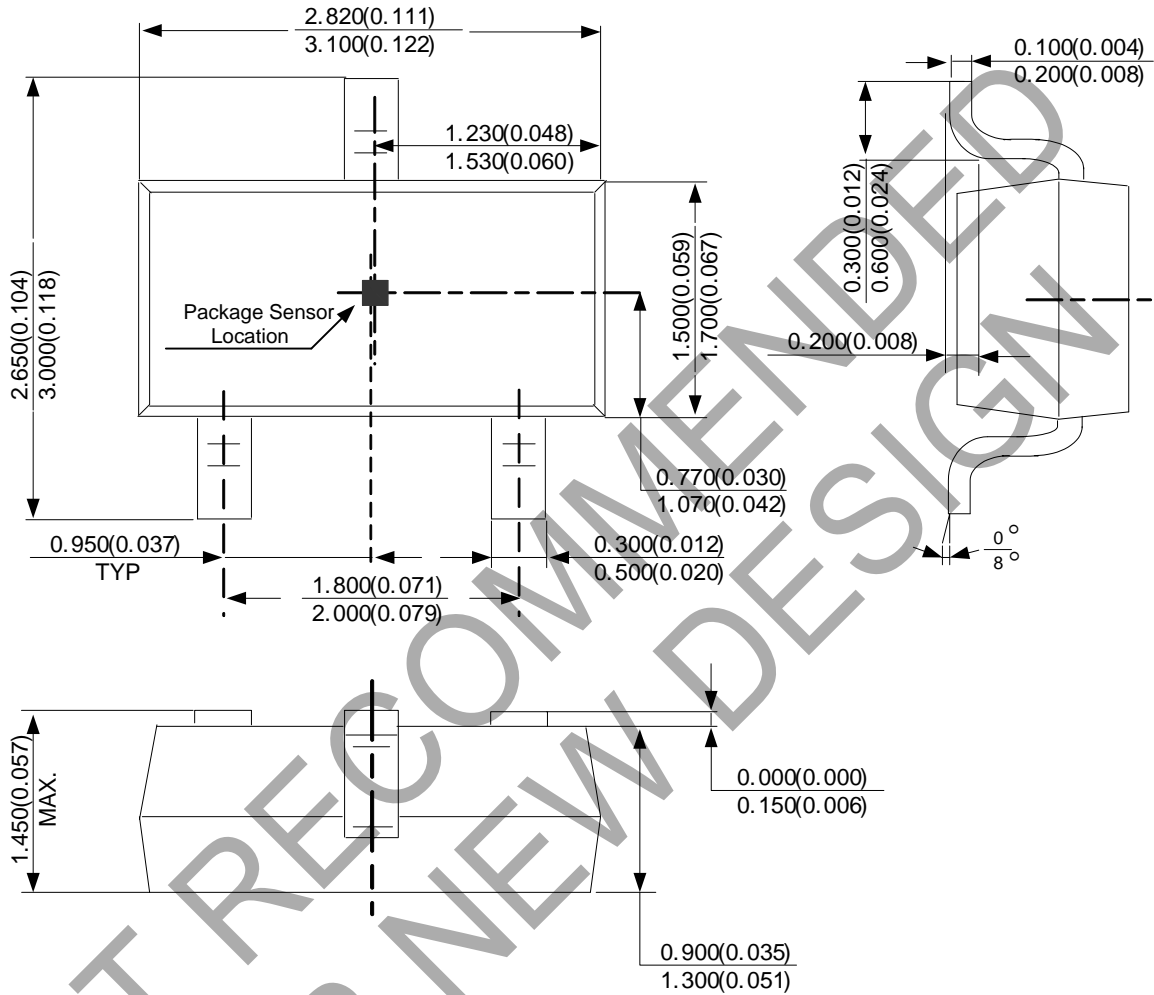

Suggested Pad Layout

Please see <http://www.diodes.com/package-outlines.html> for the latest version.

(1) Package Type: SOT-23-3

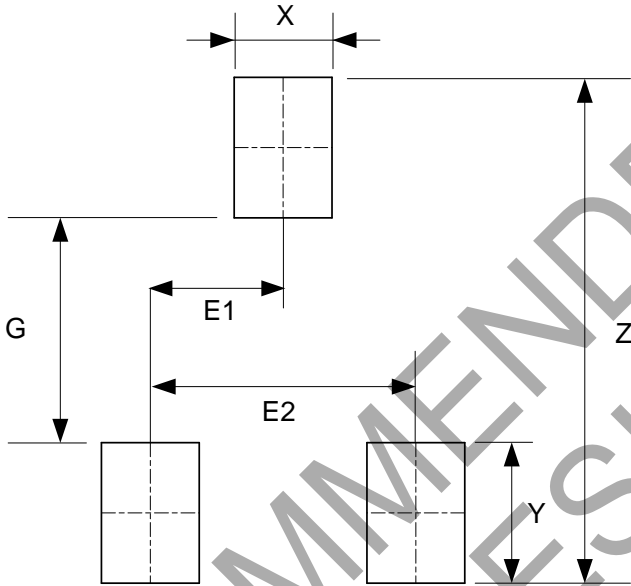

Dimensions	Z (mm)/(inch)	G (mm)/(inch)	X (mm)/(inch)	Y (mm)/(inch)	E1 (mm)/(inch)	E2 (mm)/(inch)
Value	3.600/0.142	1.600/0.063	0.700/0.028	1.000/0.039	0.950/0.037	1.900/0.075

NOT RECOMMENDED FOR NEW DESIGN

IMPORTANT NOTICE

DIODES INCORPORATED MAKES NO WARRANTY OF ANY KIND, EXPRESS OR IMPLIED, WITH REGARDS TO THIS DOCUMENT, INCLUDING, BUT NOT LIMITED TO, THE IMPLIED WARRANTIES OF MERCHANTABILITY AND FITNESS FOR A PARTICULAR PURPOSE (AND THEIR EQUIVALENTS UNDER THE LAWS OF ANY JURISDICTION).

Diodes Incorporated and its subsidiaries reserve the right to make modifications, enhancements, improvements, corrections or other changes without further notice to this document and any product described herein. Diodes Incorporated does not assume any liability arising out of the application or use of this document or any product described herein; neither does Diodes Incorporated convey any license under its patent or trademark rights, nor the rights of others. Any Customer or user of this document or products described herein in such applications shall assume all risks of such use and will agree to hold Diodes Incorporated and all the companies whose products are represented on Diodes Incorporated website, harmless against all damages.

Diodes Incorporated does not warrant or accept any liability whatsoever in respect of any products purchased through unauthorized sales channel. Should Customers purchase or use Diodes Incorporated products for any unintended or unauthorized application, Customers shall indemnify and hold Diodes Incorporated and its representatives harmless against all claims, damages, expenses, and attorney fees arising out of, directly or indirectly, any claim of personal injury or death associated with such unintended or unauthorized application.

Products described herein may be covered by one or more United States, international or foreign patents pending. Product names and markings noted herein may also be covered by one or more United States, international or foreign trademarks.

This document is written in English but may be translated into multiple languages for reference. Only the English version of this document is the final and determinative format released by Diodes Incorporated.

LIFE SUPPORT

Diodes Incorporated products are specifically not authorized for use as critical components in life support devices or systems without the express written approval of the Chief Executive Officer of Diodes Incorporated. As used herein:

A. Life support devices or systems are devices or systems which:

1. are intended to implant into the body, or
2. support or sustain life and whose failure to perform when properly used in accordance with instructions for use provided in the labeling can be reasonably expected to result in significant injury to the user.

B. A critical component is any component in a life support device or system whose failure to perform can be reasonably expected to cause the failure of the life support device or to affect its safety or effectiveness.

Customers represent that they have all necessary expertise in the safety and regulatory ramifications of their life support devices or systems, and acknowledge and agree that they are solely responsible for all legal, regulatory and safety-related requirements concerning their products and any use of Diodes Incorporated products in such safety-critical, life support devices or systems, notwithstanding any devices- or systems-related information or support that may be provided by Diodes Incorporated. Further, Customers must fully indemnify Diodes Incorporated and its representatives against any damages arising out of the use of Diodes Incorporated products in such safety-critical, life support devices or systems.

Copyright © 2020, Diodes Incorporated

www.diodes.com