

BTL Drive Single-phase Full-wave Fan Motor Driver

AM4951/R/2

General Description

The AM4951/R/2 series is a single-phase BTL output fan motor driver designed by bipolar process. This IC features high efficiency, silent operation and includes lock shutdown and automatic restart functions. When the motor is under lock condition, the lock shutdown function turns off the output current. When the lock condition is removed, the IC will restart automatically and allow DC fan to run. It is applied for high reliability and low noise application, such as personal computers, notebook, car audio, CPU cooling systems and power supplies in consumer electronics systems.

The AM4951/R series is available in MSOP-8 (12V application only) or PSOP-8 (24V application only) package. The AM4952 is available in MSOP-10 package.

Features

- BTL Output Single-phase Full-wave Linear Drive (Gain Resistor=1k to 360kΩ, Gain=51dB)
- Support Low-voltage Drive and Feature a Wide Usable Voltage Range (2.2V to 24V)
- Low Saturation Output (High Side and Low Side Saturation Voltage): $V_{SAT_TOTAL}=1.2V$ (typical, $I_{OUT}=200mA$)
- Built-in Lock Protection and Automatic Restart Circuits
- Built-in FG/RD Output
- Built-in Hall Sensor Bias (AM4952 Only, $V_{HB}=1.5V$)
- Thermal Protection Circuit
- Small-sized, High Thermal Capacity Package
- FG Output (AM4951), RD Output (AM4951R), FG and RD Output (AM4952)

Applications

- Notebook, Personal Computers
- Power Supplies in Consumer Electronics, Car Audio and Office Peripherals
- CPU Cooling Systems



Figure 1. Package Types of AM4951/R/2

Pin Configuration

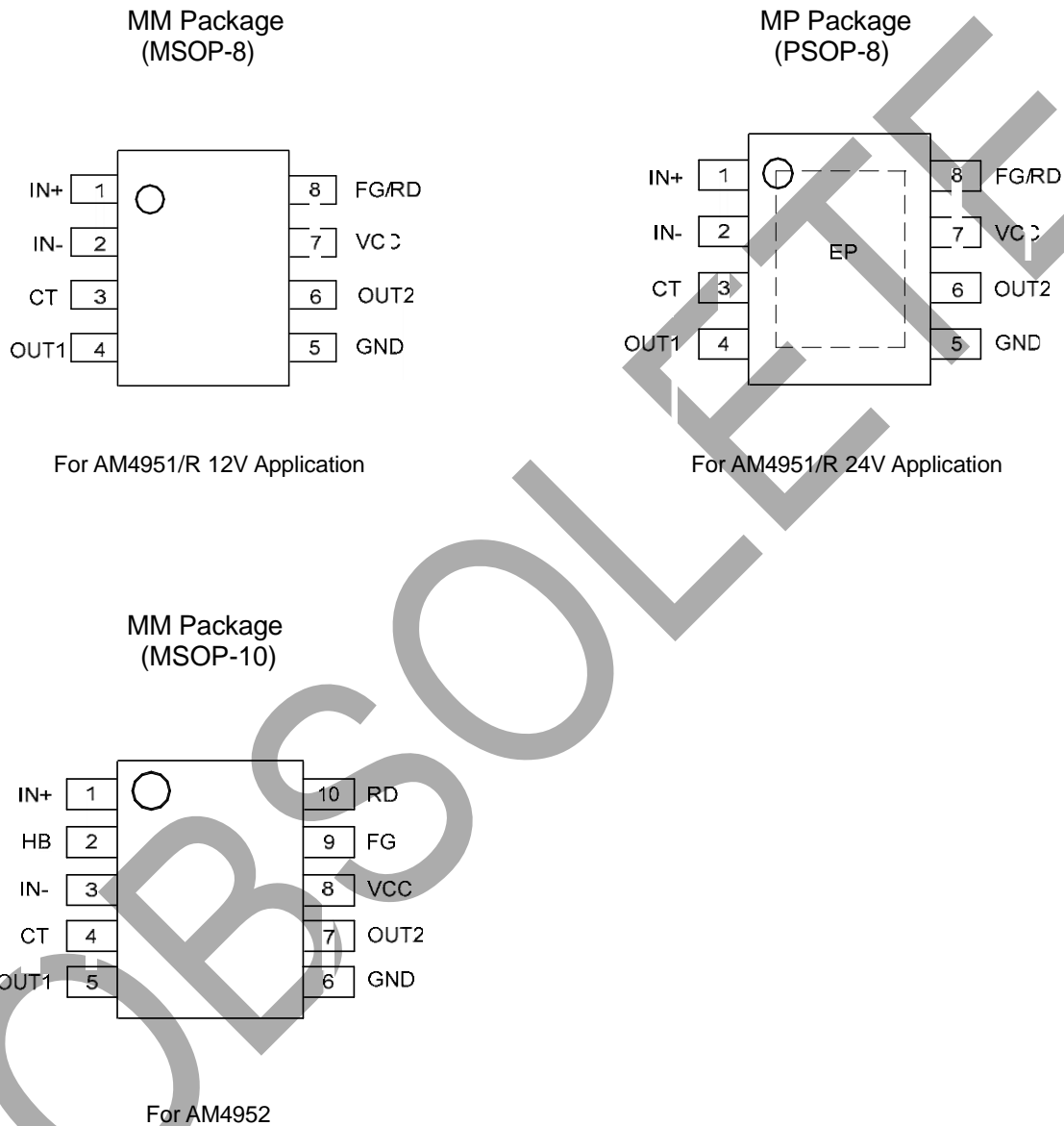

Figure 2. Pin Configuration of AM4951/R/2 (Top View)

Functional Block Diagram

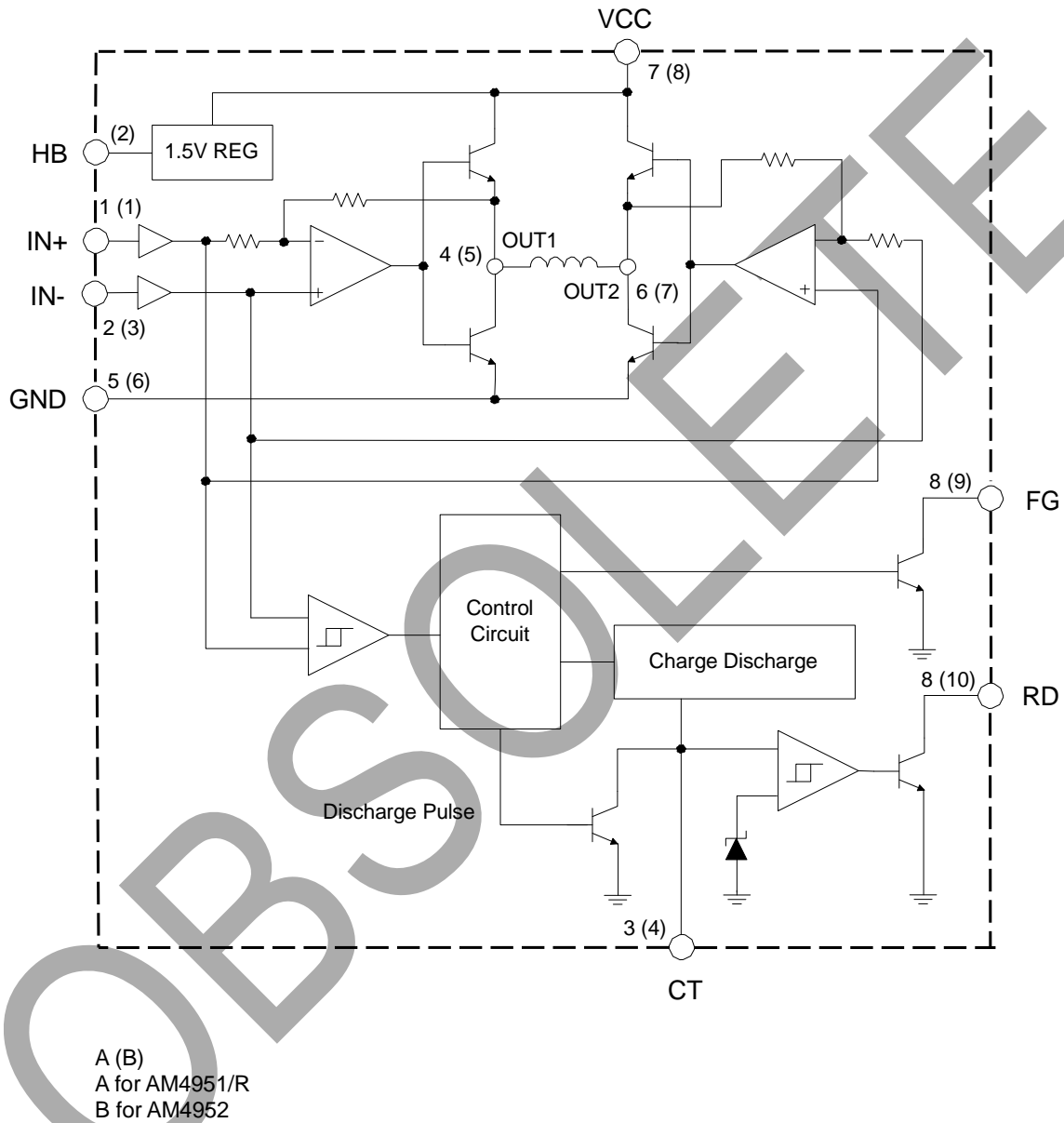
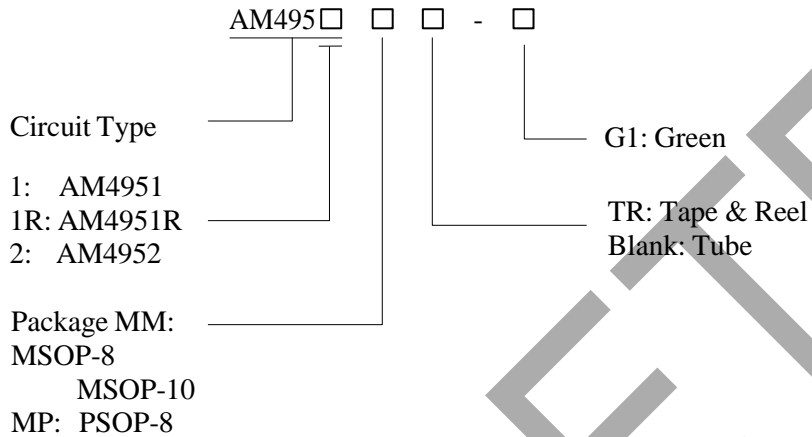

Figure 3. Functional Block Diagram of AM4951/R/2

BTL Drive Single-phase Full-wave Fan Motor Driver

AM4951/R/2

Ordering Information



Package	Temperature Range	Output Signal	Part Number	Marking ID	Packing Type
MSOP-8	-40 to 105°C	FG	AM4951MM-G1	4951MM-G1	Tube
			AM4951MMTR-G1	4951MM-G1	Tape & Reel
		RD	AM4951RMM-G1	4951RMM-G1	Tube
			AM4951RMMTR-G1	4951RMM-G1	Tape & Reel
PSOP-8		FG	AM4951MP-G1	4951MP-G1	Tube
			AM4951MPTR-G1	4951MP-G1	Tape & Reel
		RD	AM4951RMP-G1	4951RMP-G1	Tube
			AM4951RMPTR-G1	4951RMP-G1	Tape & Reel
MSOP-10	FG & RD	AM4952MM-G1	4952MM-G1	Tube	
		AM4952MMTR-G1	4952MM-G1	Tape & Reel	

BCD Semiconductor's Pb-free products, as designated with "G1" suffix in the part number, are RoHS compliant and green.

BTL Drive Single-phase Full-wave Fan Motor Driver
AM4951/R/2
Absolute Maximum Ratings (Note 1, T_A=25°C)

Parameter	Symbol	Value		Unit
Supply Voltage	V _{CC}	28		V
Peak Output Current	I _{OUT}	500		mA
FG/RD Pull-up Voltage	V _{FG} /V _{RD}	28		V
FG/RD Output Current	I _{FG} /I _{RD}	10		mA
Thermal Resistance (Junction to Ambient)	θ _{JA}	MSOP-8	205	°C/W
		PSOP-8	110	
		MSOP-10	195	
Thermal Resistance (Junction to Case)	θ _{JC}	MSOP-8	48	°C/W
		PSOP-8	36	
		MSOP-10	46	
Power Dissipation	P _D	MSOP-8	585	mW
		PSOP-8	960	mW
		MSOP-10	585	mW
Operating Temperature	T _{OP}	-40 to 125		°C
Storage Temperature	T _{STG}	-55 to 150		°C

Note 1: Stresses greater than those listed under “Absolute Maximum Ratings” may cause permanent damage to the device. These are stress ratings only, and functional operation of the device at these or any other conditions beyond those indicated under “Recommended Operating Conditions” is not implied. Exposure to “Absolute Maximum Ratings” for extended periods may affect device reliability.

Recommended Operating Conditions

Parameter	Symbol	Min	Max	Unit
Supply Voltage	V _{CC}	2.2	24	V
Hall Input Voltage	V _{ICM}	0	V _{CC} -1.5	V
Operating Ambient Temperature	T _A	-40	105	°C

BTL Drive Single-phase Full-wave Fan Motor Driver
AM4951/R/2
Electrical Characteristics
 $V_{CC}=12V$, $T_A=25^{\circ}C$, unless otherwise specified.

Parameter	Symbol	Conditions	Min	Typ	Max	Unit
Supply Current	I_{CC1}	$V_{CT}=L$	3	6	9	mA
	I_{CC2}	$V_{CT}=H$	2.5	5	7.5	mA
CT Charge Current	I_{CHG}		0.9	1.3	1.5	μA
CT Discharge Current	I_{DHG}		0.1	0.15	0.25	μA
CT Charge/Discharge Current Ratio	R_{CT}	I_{CHG} / I_{DHG}	6	8	10	
CT Clamp Voltage	V_{CL}		1.3	1.5	1.7	V
CT Comparator Voltage	V_{CP}		0.3	0.5	0.7	V
OUT Low Saturation Voltage	V_{SAT_L}	$I_{OUT}=200mA$		0.25	0.45	V
OUT High Saturation Voltage	V_{SAT_H}	$I_{OUT}=200mA$		0.95	1.2	V
Hall Input Sensitivity	V_{HN}			7	15	mV
FG Low Level Voltage (For AM4951/2)	V_{FG}	$I_{FG}=5mA$		0.15	0.3	V
FG Leakage Current (For AM4951/2)	I_{FGL}	$V_{FG}=15V$		1	30	μA
RD Low Level Voltage (For AM4951R/2)	V_{RD}	$I_{RD}=5mA$		0.15	0.3	V
RD Leakage Current (For AM4951R/2)	I_{RDL}	$V_{RD}=15V$		1	30	μA
HB Voltage (For AM4952)	V_{HB}	$I_{HB}=1mA$	1.35	1.5	1.65	V

BTL Drive Single-phase Full-wave Fan Motor Driver

AM4951/R/2

OBSOLETE – PART DISCONTINUED

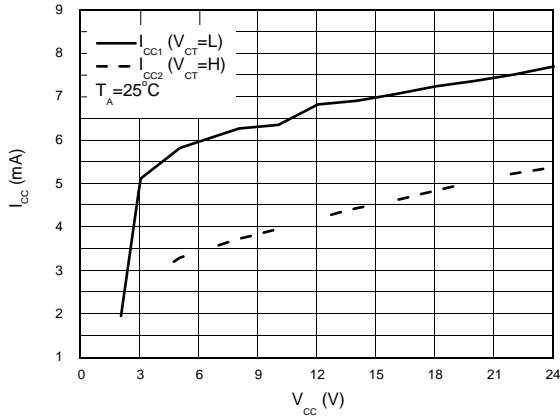

Figure 4. Supply Current vs. Supply Voltage

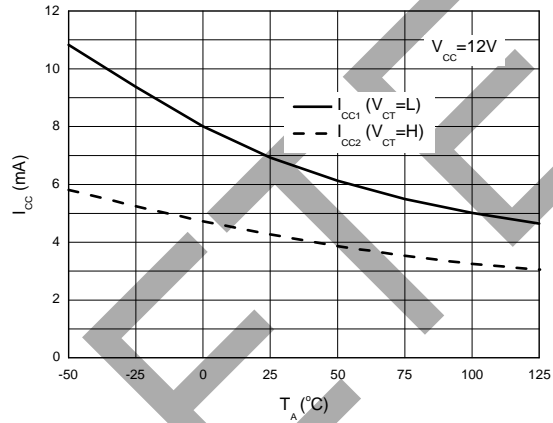

Figure 5. Supply Current vs. Ambient Temperature

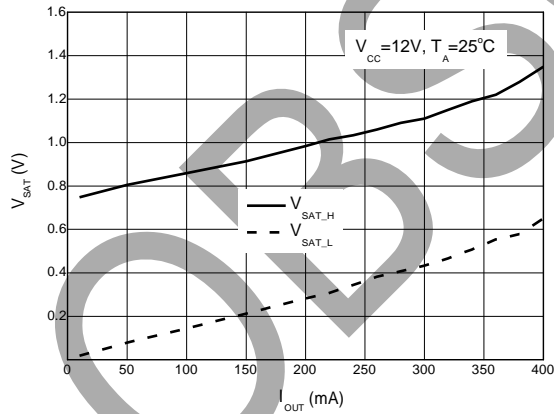

Figure 6. Saturation Voltage vs. Output Current

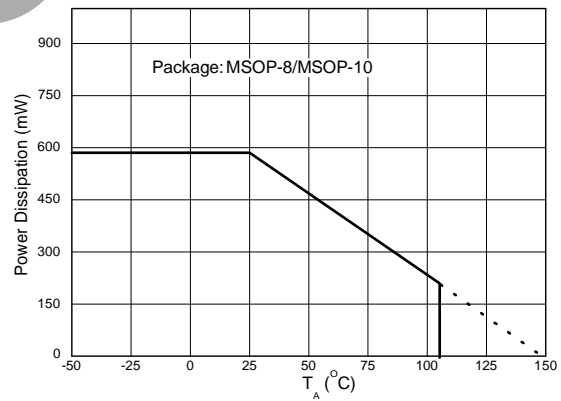

Figure 7. Power Dissipation vs. Ambient Temperature

Typical Performance Characteristics (Continued)

Figure 8. Power Dissipation vs. Ambient Temperature

OBSOLETE

Typical Application

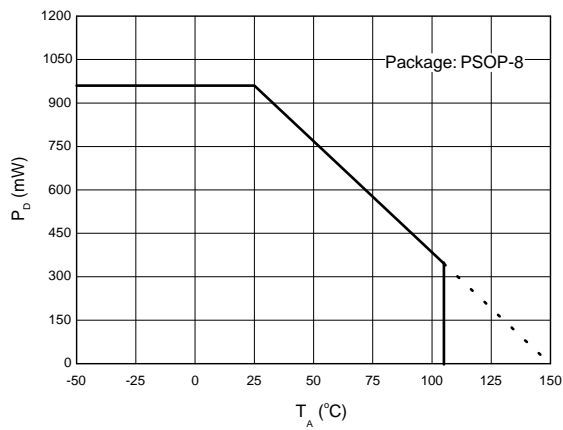
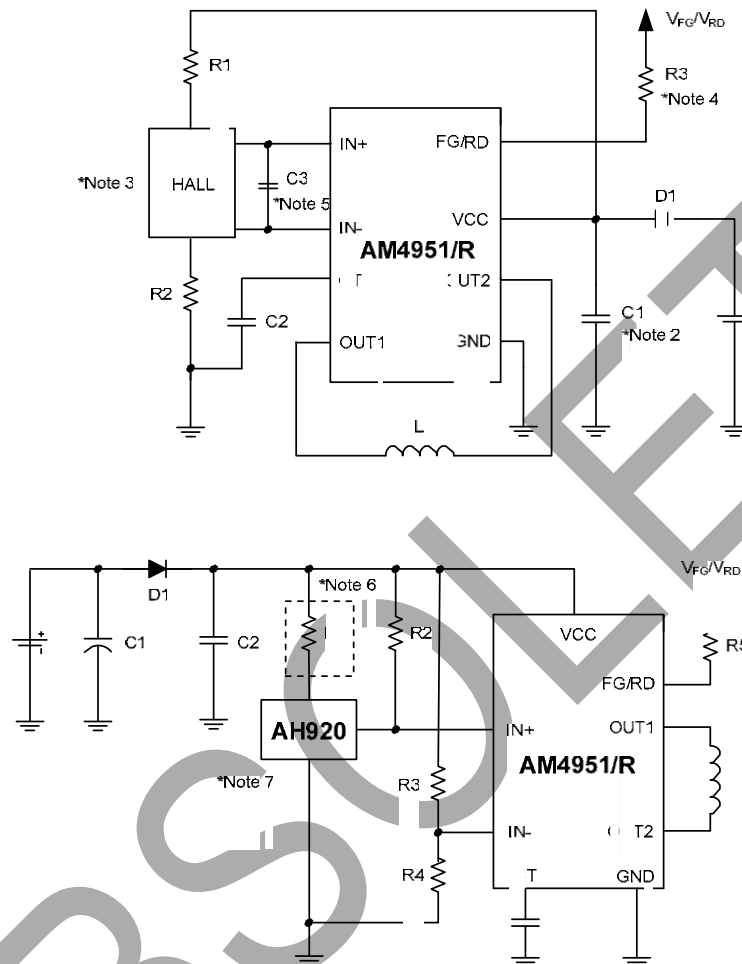

Note 2: Adding D1 can protect the IC from destruction by reverse connection. If D1 is used, it is necessary to insert a capacitor C1 to provide a regenerative current route. Similarly, if there is no nearby capacitor on the fan power supply line, C1 will also be necessary to improve reliability. Its capacity should be larger than $2.2\mu\text{F}$.

Note 3: If the Hall sensor bias is taken from V_{CC} , A $1/2 V_{CC}$ bias, as shown in the figure must be used. Adjusting the value of R1 and R2 may achieve better startup characteristics and efficiency, even quiet operation.

Note 4: This pin must be left open if unused.

Note 5: If the line between Hall sensor output and Hall sensor input of IC is long, the noise may occur in this line. But it can be eliminated by adding a capacitor C3.

Note 6: Each of R2, R3, R4 and R5 (AM4951/R only) is recommended to be $51\text{k}\Omega$ typical. R1 is recommended to be $2\text{k}\Omega$ and must be added when V_{CC} is larger than 20V .

Note 7: The package of AH920 is SOT-23-3. If it is packaged in TO-92S-3, please exchange IN- with IN+.

Figure 9. Typical Application of AM4951/R

Typical Application (Continued)

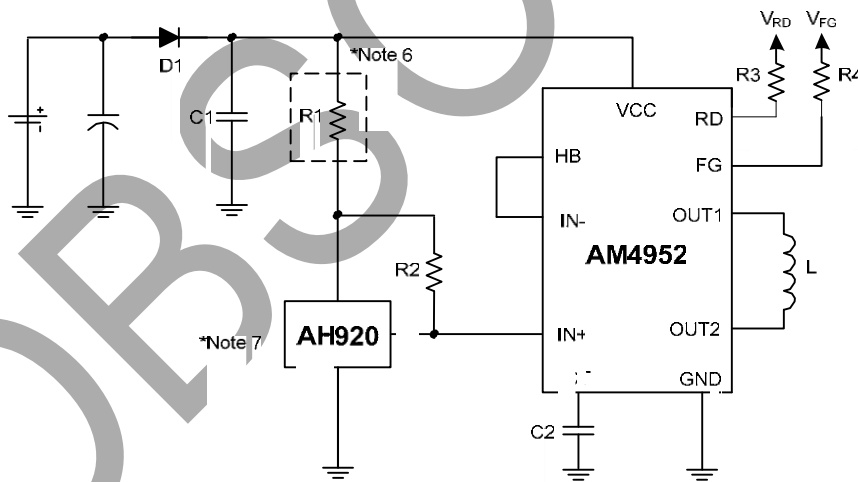
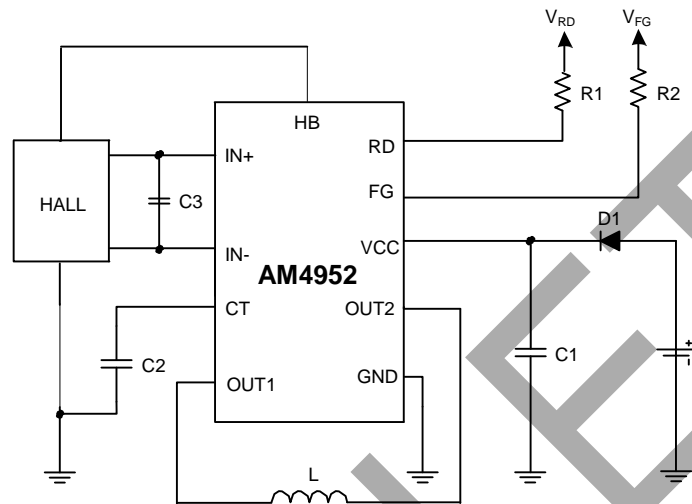
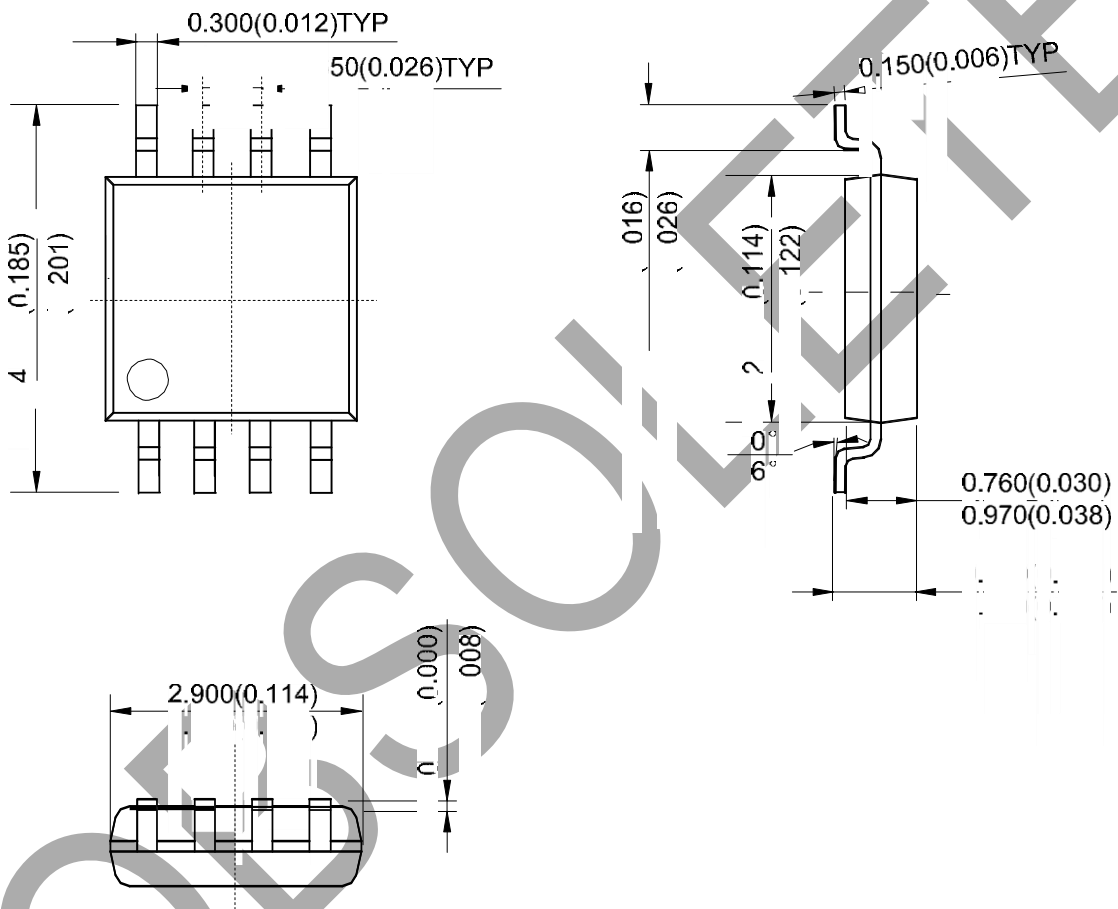

Figure 10. Typical Application of AM4952

Mechanical Dimensions

MSOP-8

Unit: mm(inch)



Note: Eject hole, oriented hole and mold mark is optional.

OBSOLETE - PART DISCONTINUED

Mechanical Dimensions (Continued)

PSOP-8

Unit: mm(inch)

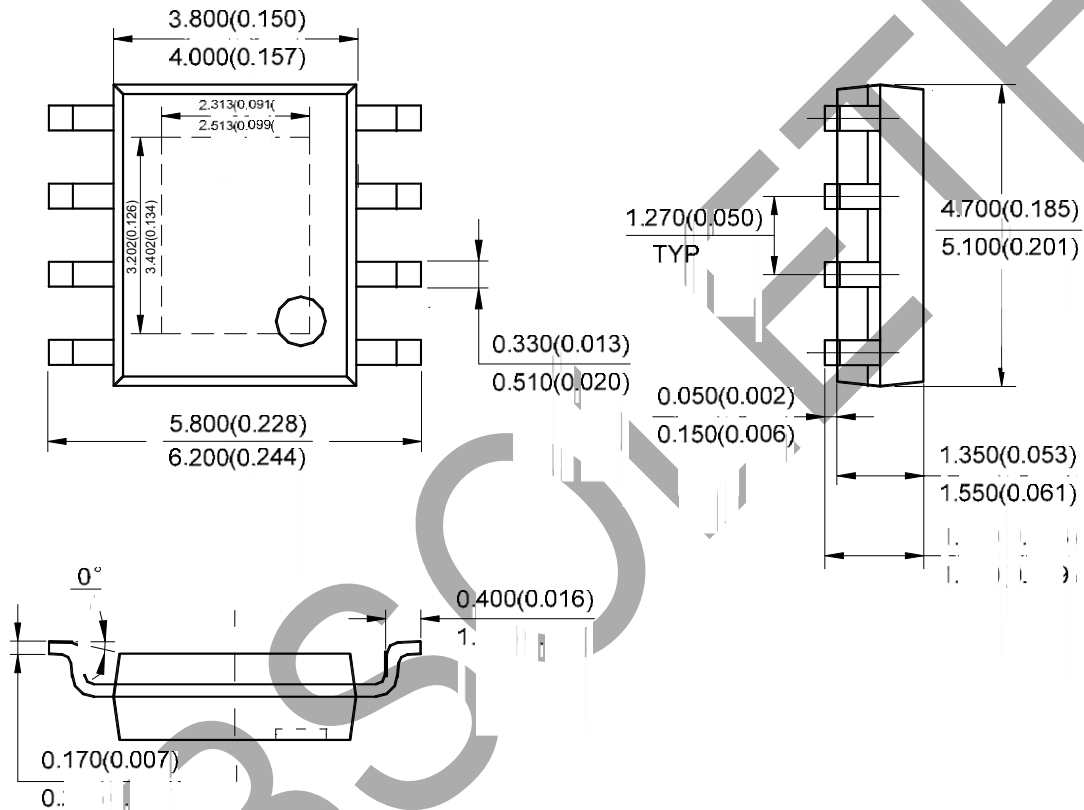

Note: Eject hole, oriented hole and mold mark is optional.

OBSOLETE - PART DISCONTINUED

Mechanical Dimensions (Continued)

MSOP-10

Unit: mm(inch)

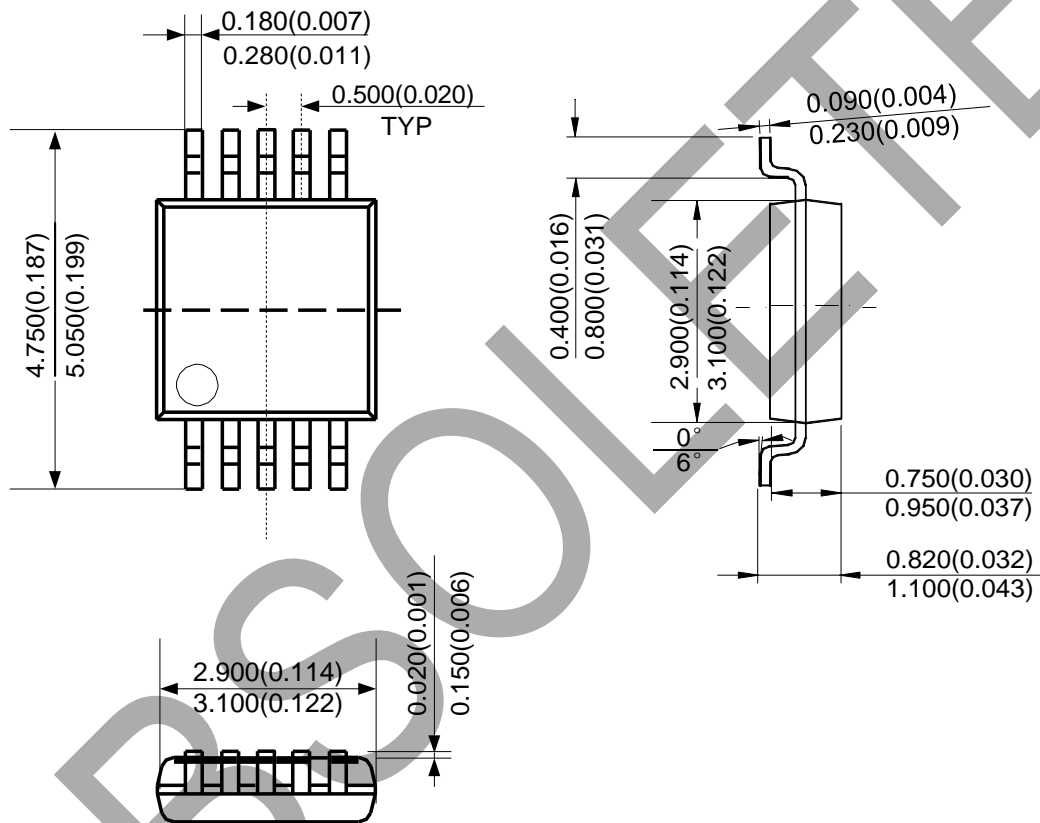

Note: Eject hole, oriented hole and mold mark is optional.

OBSOLETE - PART DISCONTINUED

IMPORTANT NOTICE

1. DIODES INCORPORATED (Diodes) AND ITS SUBSIDIARIES MAKE NO WARRANTY OF ANY KIND, EXPRESS OR IMPLIED, WITH REGARDS TO ANY INFORMATION CONTAINED IN THIS DOCUMENT, INCLUDING, BUT NOT LIMITED TO, THE IMPLIED WARRANTIES OF MERCHANTABILITY, FITNESS FOR A PARTICULAR PURPOSE OR NON-INFRINGEMENT OF THIRD PARTY INTELLECTUAL PROPERTY RIGHTS (AND THEIR EQUIVALENTS UNDER THE LAWS OF ANY JURISDICTION).
2. The Information contained herein is for informational purpose only and is provided only to illustrate the operation of Diodes' products described herein and application examples. Diodes does not assume any liability arising out of the application or use of this document or any product described herein. This document is intended for skilled and technically trained engineering customers and users who design with Diodes' products. Diodes' products may be used to facilitate safety-related applications; however, in all instances customers and users are responsible for (a) selecting the appropriate Diodes products for their applications, (b) evaluating the suitability of Diodes' products for their intended applications, (c) ensuring their applications, which incorporate Diodes' products, comply the applicable legal and regulatory requirements as well as safety and functional-safety related standards, and (d) ensuring they design with appropriate safeguards (including testing, validation, quality control techniques, redundancy, malfunction prevention, and appropriate treatment for aging degradation) to minimize the risks associated with their applications.
3. Diodes assumes no liability for any application-related information, support, assistance or feedback that may be provided by Diodes from time to time. Any customer or user of this document or products described herein will assume all risks and liabilities associated with such use, and will hold Diodes and all companies whose products are represented herein or on Diodes' websites, harmless against all damages and liabilities.
4. Products described herein may be covered by one or more United States, international or foreign patents and pending patent applications. Product names and markings noted herein may also be covered by one or more United States, international or foreign trademarks and trademark applications. Diodes does not convey any license under any of its intellectual property rights or the rights of any third parties (including third parties whose products and services may be described in this document or on Diodes' website) under this document.
5. Diodes' products are provided subject to Diodes' Standard Terms and Conditions of Sale (<https://www.diodes.com/about/company/terms-and-conditions/terms-and-conditions-of-sales/>) or other applicable terms. This document does not alter or expand the applicable warranties provided by Diodes. Diodes does not warrant or accept any liability whatsoever in respect of any products purchased through unauthorized sales channel.
6. Diodes' products and technology may not be used for or incorporated into any products or systems whose manufacture, use or sale is prohibited under any applicable laws and regulations. Should customers or users use Diodes' products in contravention of any applicable laws or regulations, or for any unintended or unauthorized application, customers and users will (a) be solely responsible for any damages, losses or penalties arising in connection therewith or as a result thereof, and (b) indemnify and hold Diodes and its representatives and agents harmless against any and all claims, damages, expenses, and attorney fees arising out of, directly or indirectly, any claim relating to any noncompliance with the applicable laws and regulations, as well as any unintended or unauthorized application.
7. While efforts have been made to ensure the information contained in this document is accurate, complete and current, it may contain technical inaccuracies, omissions and typographical errors. Diodes does not warrant that information contained in this document is error-free and Diodes is under no obligation to update or otherwise correct this information. Notwithstanding the foregoing, Diodes reserves the right to make modifications, enhancements, improvements, corrections or other changes without further notice to this document and any product described herein. This document is written in English but may be translated into multiple languages for reference. Only the English version of this document is the final and determinative format released by Diodes.
8. Any unauthorized copying, modification, distribution, transmission, display or other use of this document (or any portion hereof) is prohibited. Diodes assumes no responsibility for any losses incurred by the customers or users or any third parties arising from any such unauthorized use.
9. This Notice may be periodically updated with the most recent version available at <https://www.diodes.com/about/company/terms-and-conditions/important-notice>

DIODES is a trademark of Diodes Incorporated in the United States and other countries.
The Diodes logo is a registered trademark of Diodes Incorporated in the United States and other countries.
© 2022 Diodes Incorporated. All Rights Reserved.

www.diodes.com