

## Description

The DIODES™ AP1695-20C is a high performance AC/DC power factor corrector for mains dimmable LED driver applications. The device uses Pulse Frequency Modulation (PFM) technology to regulate output current while achieving high power factor and low THD. It operates as a BCM (Boundary Conduction Mode) which is good for EMI.

The AP1695-20C internally integrates a high voltage MOSFET which can realize a lower BOM cost. The AP1695-20C provides accurate constant current (CC) regulation while removing the opto-coupler and secondary control circuitry. It also eliminates the need of loop compensation circuitry while maintaining stability. It can meet the requirement of IEC6100-3-2 harmonic standard.

The AP1695-20C features low start-up current and low operation current. It adopts valley on switching mode to achieve high efficiency. It also has rich protection features including over voltage, short circuit, and over temperature protection.

The AP1695-20C provides the dimmable LED driver with a wide dimmer compatibility including leading edge and trailing edge dimmer. The AP1695-20C can achieve deep dimming down to 1%, while the dimming curve is compliant with the standard of NEMA SSL6.

The AP1695-20C is available in SO-7 package.

## Features

- Boundary Conduction Mode (BCM) Operation to Achieve High-Efficiency
- High PF and Low THD (PF>0.9, THD<30%)
- High Efficiency Without Dimmer
- Wide Range of Dimmer Compatibility
- Dimming Curve Compliant with NEMA SSL6
- Low Start-up Current
- Tight LED Current
- Tight LED Open Voltage
- Valley-Mode Switching to Minimize the Transition Loss
- Easy EMI
- Internal Protections:
  - Under Voltage Lock Out (UVLO)
  - Leading-Edge Blanking (LEB)
  - Output Short Protection
  - Output Open Protection
  - Over Temperature Protection
- Flexible for Design with Small Form Factor and Very Low BOM Cost
- **Totally Lead-Free & Fully RoHS Compliant (Notes 1 & 2)**
- **Halogen and Antimony Free. "Green" Device (Note 3)**
- **For automotive applications requiring specific change control (i.e. parts qualified to AEC-Q100/101/104/200, PPAP capable, and manufactured in IATF 16949 certified facilities), please [contact us](#) or your local Diodes representative. <https://www.diodes.com/quality/product-definitions/>**

Notes: 1. No purposely added lead. Fully EU Directive 2002/95/EC (RoHS), 2011/65/EU (RoHS 2) & 2015/863/EU (RoHS 3) compliant.  
 2. See <https://www.diodes.com/quality/lead-free/> for more information about Diodes Incorporated's definitions of Halogen- and Antimony-free, "Green" and Lead-free.  
 3. Halogen- and Antimony-free "Green" products are defined as those which contain <900ppm bromine, <900ppm chlorine (<1500ppm total Br + Cl) and <1000ppm antimony compounds.

## Pin Assignments

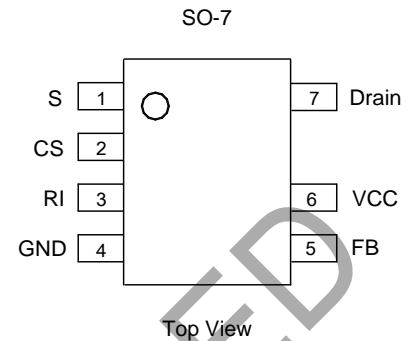

## Applications

- Mains dimmable LED lighting

**Typical Applications Circuit**

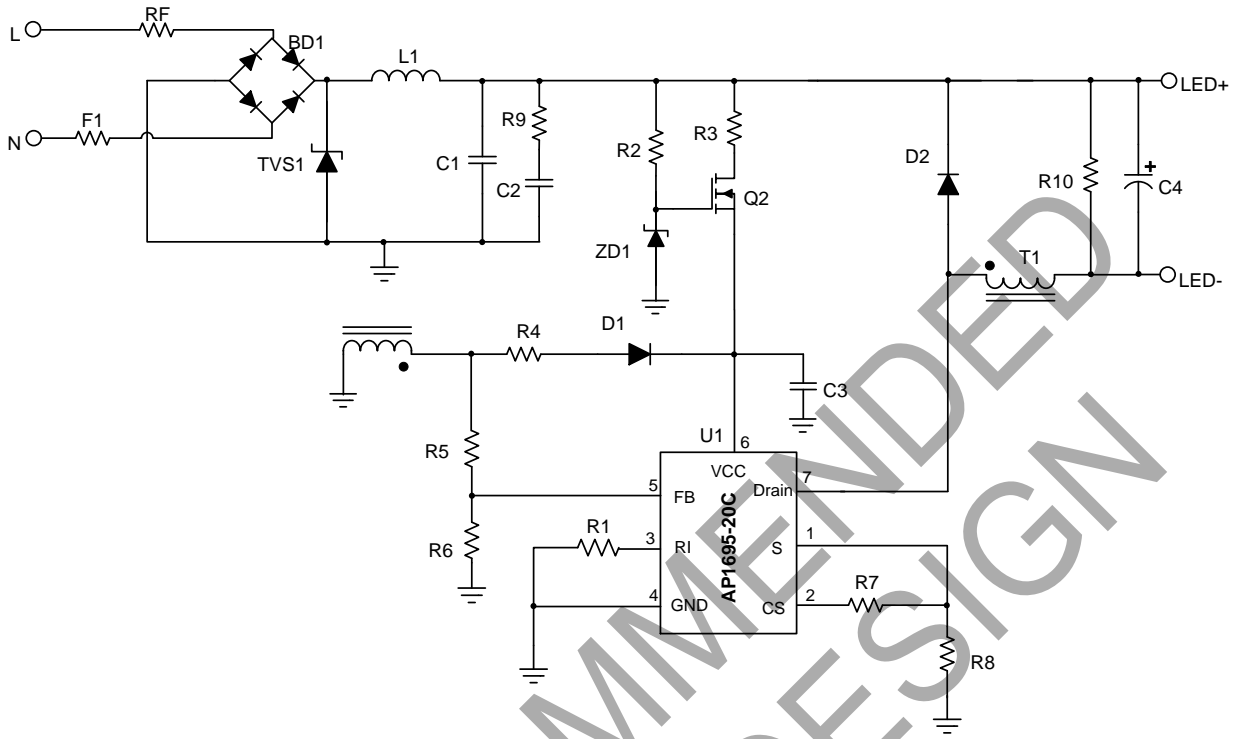

Typical Buck Application

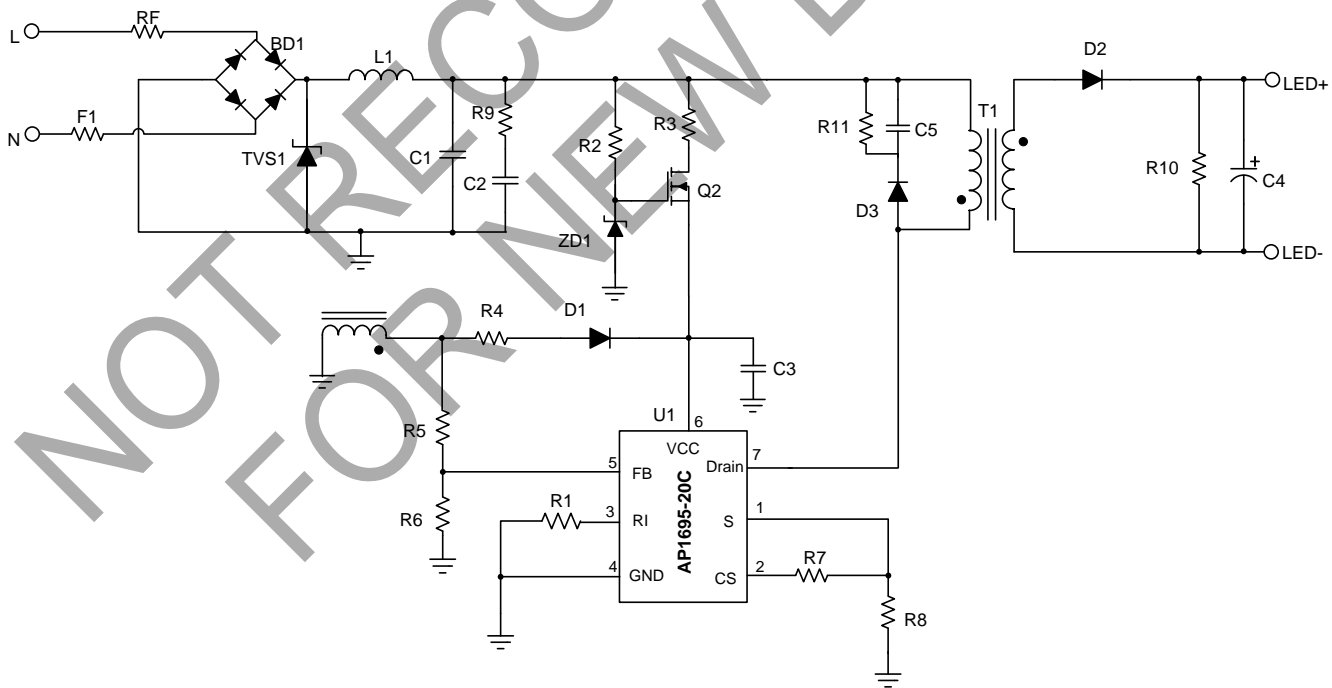

Typical Fly-Back Application



**Functional Block Diagram**

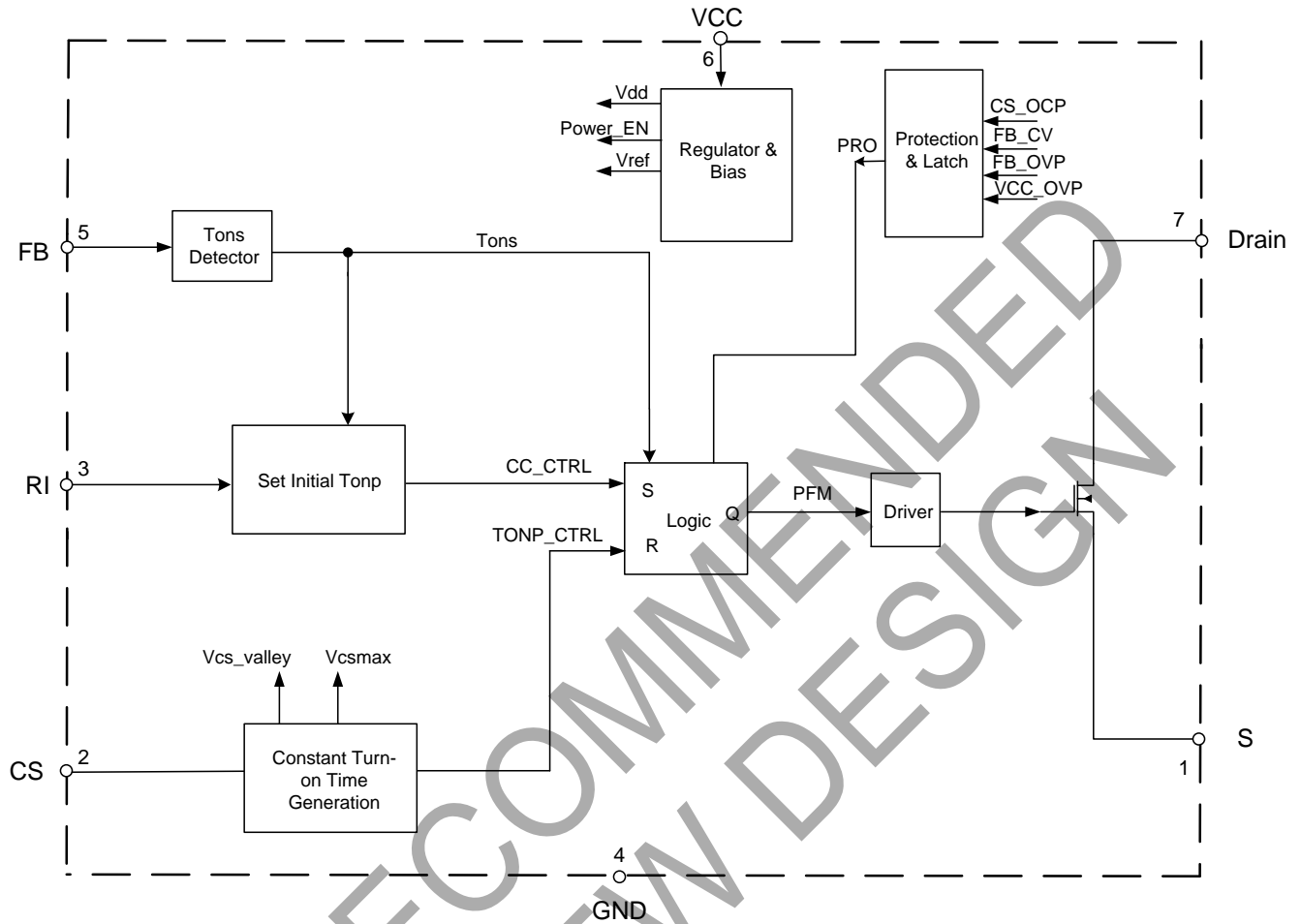

**Absolute Maximum Ratings** (Note 4) (@T<sub>A</sub> = +25°C, unless otherwise specified.)

Symbol	Parameter	Rating	Unit
V <sub>CC</sub>	Power Supply Voltage	-0.3 to 35	V
V <sub>CS</sub>	Voltage at CS to GND	-0.3 to 7	V
V <sub>FB</sub>	FB Input Voltage	-40 to 10	V
V <sub>Drain</sub>	Voltage on Drain	600	V
I <sub>D</sub>	Continuous Drain Current T <sub>C</sub> = +25°C	2.0	A
T <sub>J</sub>	Operating Junction Temperature	-40 to +150	°C
T <sub>STG</sub>	Storage Temperature	-65 to +150	°C
T <sub>LEAD</sub>	Lead Temperature (Soldering, 10 sec)	+300	°C
P <sub>D</sub>	Power Dissipation (T <sub>A</sub> = +50°C)	0.65	W
θ <sub>JA</sub>	Thermal Resistance (Junction to Ambient)	160	°C/W
—	ESD (Human Body Model)	±2000	V
—	ESD (Machine Model)	±200	V

Note: 4. Stresses greater than those listed under *Absolute Maximum Ratings* can cause permanent damage to the device. These are stress ratings only, and functional operation of the device at these or any other conditions beyond those indicated under *Recommended Operating Conditions* is not implied. Exposure to *Absolute Maximum Ratings* for extended periods can affect device reliability.

**Recommended Operating Conditions**

Symbol	Parameter	Min	Max	Unit
V <sub>CC</sub>	Power Supply Voltage	7	25	V
T <sub>A</sub>	Ambient Temperature	-40	+105	°C

**Electrical Characteristics** (@T<sub>A</sub> = +25°C, unless otherwise specified.)

Symbol	Parameter	Conditions	Min	Typ	Max	Unit
<b>UVLO Section</b>						
V <sub>TH</sub> (ST)	Start-up Threshold	—	13	14.5	16	V
V <sub>OPR</sub> (Min)	Minimum Operating Voltage	After turn on	5.5	6.5	7.5	V
V <sub>CC_OVP</sub>	VCC OVP Voltage	—	27	29	31	V
—	VCC Delatch Voltage (Note 5)	—	3	4	5	V
<b>Standby Current Section</b>						
I <sub>ST</sub>	Start-up Current	V <sub>CC</sub> = V <sub>TH</sub> (ST) - 0.5V Before start up	—	—	20	μA
I <sub>CC</sub> (OPR)	Operating Current	Static	—	900	1300	μA
<b>Current Sense Section</b>						
V <sub>CS_REF</sub>	Current Sense Reference	—	—	1	—	V
V <sub>CS_CLAMP</sub>	Current Sense Reference Clamp	—	1.2	1.4	—	V
t <sub>ONP_MIN</sub>	Minimum t <sub>ONP</sub>	—	700	—	1000	ns
t <sub>D(H-L)</sub>	Delay to Output (Note 5)	—	50	150	250	ns
<b>Feedback Input Section</b>						
I <sub>FB</sub>	Feedback Pin Input Leakage Current	V <sub>FB</sub> = 2V	—	—	4	μA
V <sub>FB_CV</sub>	FB CV Threshold	—	3.8	4	4.2	V
V <sub>FB_OVP</sub>	FB OVP Threshold	—	4.5	6	7.5	V
<b>Internal MOSFET Section</b>						
R <sub>DS(ON)</sub>	Drain-Source On-State Resistance	V <sub>GS</sub> = 10V, I <sub>D</sub> = 1.25A	—	—	5.5	Ω
V <sub>BR(Drain)</sub>	Drain-Source Breakdown Voltage	V <sub>GS</sub> = 0V, I <sub>D</sub> = 250μA	600	—	—	V
I <sub>DSS</sub>	Drain-Source Leakage Current	V <sub>DS</sub> = 600V, V <sub>GS</sub> = 0V	—	—	1	μA
<b>Output Current</b>						
—	System Output Current on Final Test Board	—	—	—	±2	%
<b>Over Temperature Protection Section</b>						
—	Shutdown Temperature (Note 5)	—	+150	—	—	°C
—	Temperature Hysteresis (Note 5)	—	—	+20	—	°C

Note: 5. These parameters, although guaranteed by design, are not 100% tested in production.

**Performance Characteristics**

**CV Threshold vs. Supply Voltage**

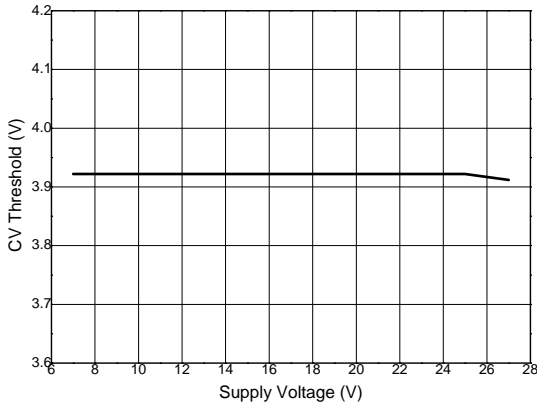

**Start-up Voltage vs. Ambient Temperature**

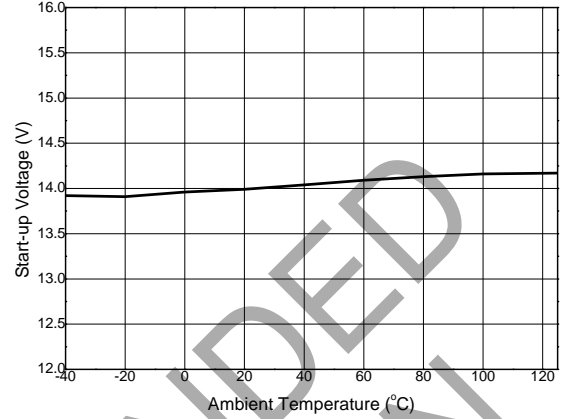

**Minimal Operating Voltage vs. Ambient Temperature**

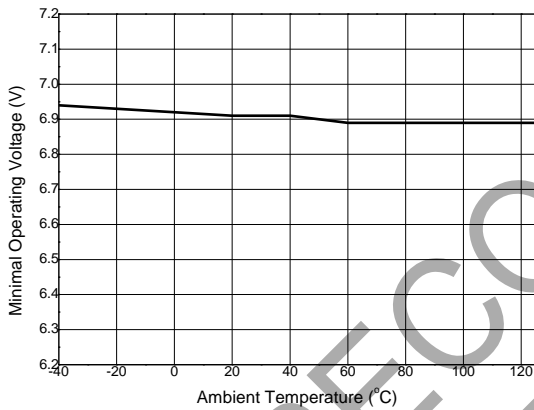

**Start-up Current vs. Ambient Temperature**

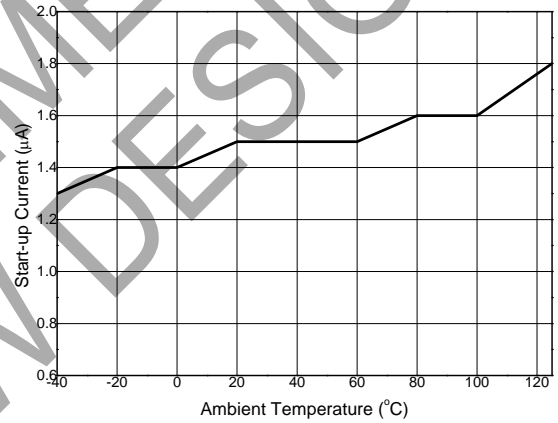

**Operating Current vs. Ambient Temperature**

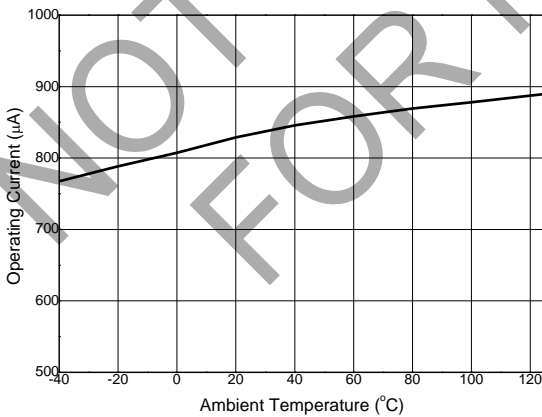

**CV Threshold vs. Ambient Temperature**

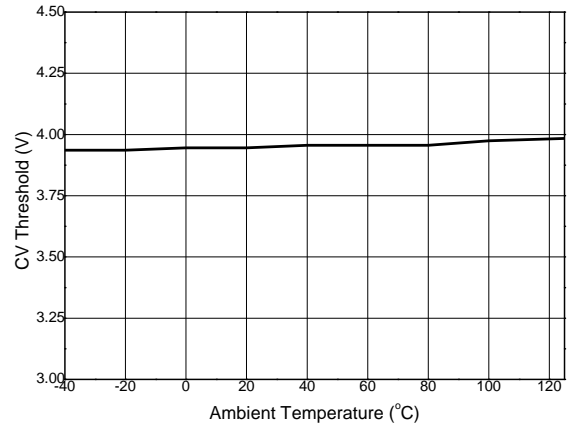

**Performance Characteristics** (continued)

**FB Leakage Current vs. Ambient Temperature**

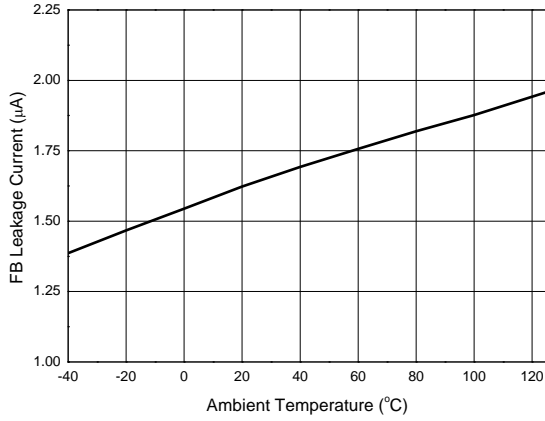

**Supply Current vs. Supply Voltage**

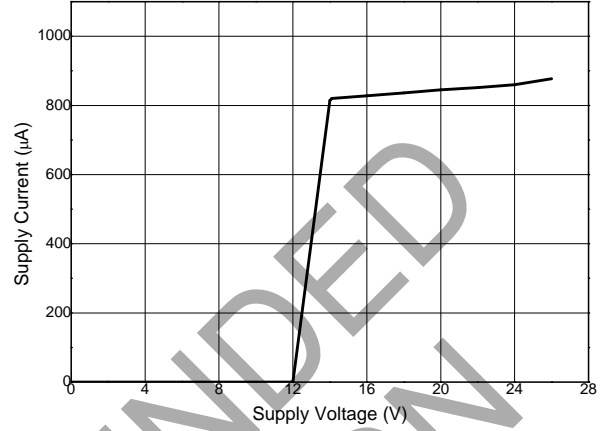

NOT RECOMMENDED FOR NEW DESIGN

**Application Information Based on Buck Structure**

The AP1695-20C uses constant on time control method within one AC cycle to achieve the high power factor. When the dimmer is connected to the driver, although a part of input voltage is cut off by the dimmer, the system still operates as constant on time mode, in this way good dimmer compatibility can be realized.

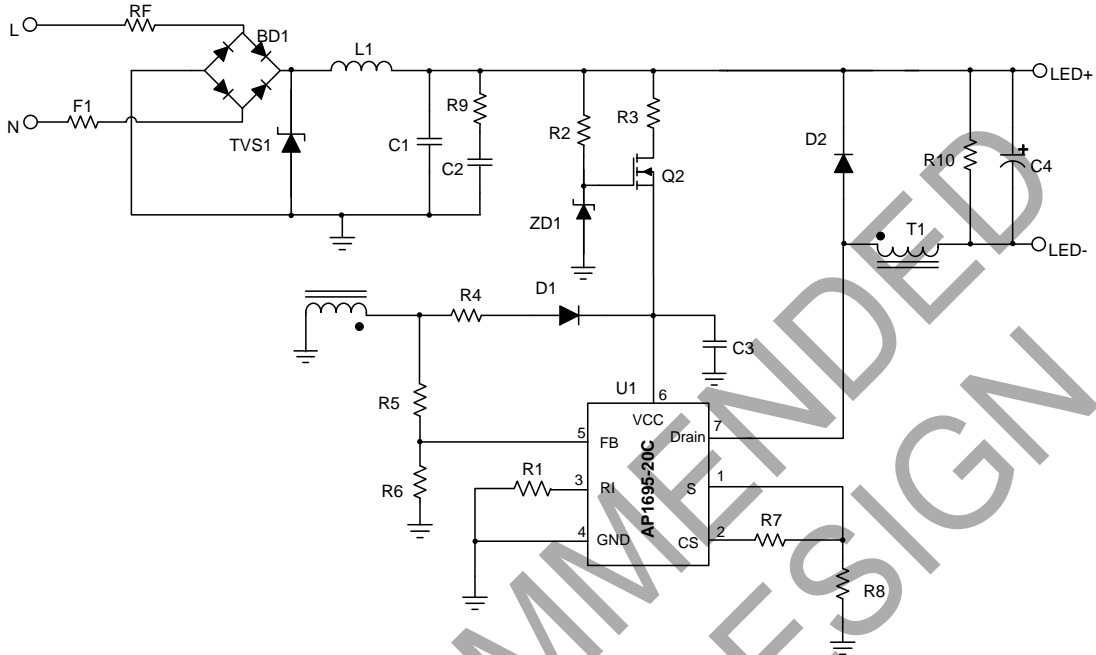

Figure 1. Typical Buck Application Circuit

When the dimmer is connected, and the conduction angle of the dimmer is  $\pi - \alpha$ , according to the control principle of the IC, the output current can be got as below:

$$I_o(\alpha, \theta) = \frac{1}{2} \cdot I_{pk}(\alpha, \theta) = \begin{cases} \frac{1}{2} \cdot \frac{V_{cs\_ref}}{R8} \cdot \sin(\theta) & \text{if } (\theta > \alpha) \\ 0 & \text{else} \end{cases}$$

In consideration of the dead zone of the buck structure, the output current DC value can be calculated as below:

$$I_{o\_mean} = k \cdot \frac{1}{\pi} \int_0^{\pi} I_o(\alpha, \theta) d\theta$$

Where,

$V_{cs\_ref}$  is the reference of the current sense, and the typical value is 1V.

$\alpha$  is the cut off angle of dimmer.

$\theta$  is the phase of the input voltage.

k is the current modification coefficient, and the value is approximately 0.7.

When no dimmer is connected with the driver ( $\alpha = 0$ ), the output current DC value can be got as:

$$I_{o\_mean} = k \cdot \frac{1}{\pi} \cdot \frac{V_{cs\_ref}}{R8}$$



## Application Information Based on Buck Structure (continued)

### Design Parameters

#### Setting the Current Sense Resistor R8

According to the equation of the output current, the current sense resistor R8 is determined:

$$R8 = k \cdot \frac{V_{cs\_ref}}{\pi \cdot I_{o\_mean}}$$

#### Transformer Selection

The typical non-isolated buck circuit in Figure 1 is usually selected, and the system is operating at boundary conduction mode. The switching frequency at the crest is set as  $f_{min}$ , the inductance can be calculated as below:

$$L = \frac{(\sqrt{2} \cdot V_{in\_rms} - V_o) \cdot R8 \cdot V_o}{V_{cs\_ref} \cdot \sqrt{2} \cdot V_{in\_rms} \cdot f_{min}}$$

Where,

$V_o$  is the output voltage.

$V_{in\_rms}$  is the RMS value of the input voltage.

According to Ferrari's law of electromagnetic induction, the winding turns number of the buck inductance  $N_L$  is:

$$N_L = \frac{L \cdot i_{pk}}{A_e \cdot B_m} = \frac{L \cdot V_{cs\_ref}}{A_e \cdot B_m \cdot R8}$$

Where,

$A_e$  is the core effective area.

$B_m$  is the maximum magnetic flux density.

The auxiliary winding is power supply for  $V_{cc}$ , the winding turns number  $N_{aux}$  is:

$$N_{aux} = N_L \cdot \frac{V_{cc}}{V_o + V_d}$$

Where,

$V_{cc}$  is the power supply voltage for IC from auxiliary winding.

$V_d$  is the voltage drop of the freewheel diode.

#### Setting the Initial On Time

As the AP1695-20C adopts constant on time control method, the AP1695-20C will generate an initial on time to start a working cycle. If the initial on time is longer than the rated on time, overshoot will happen. The initial on time is determined by resistor R1 shown in Figure 1.

According to initial on time generation mechanism, the  $t_{on\_initial}$  is:

$$t_{on\_initial} = 80 \cdot R1 \cdot 10^{-12} s$$

**Application Information Based on Buck Structure** (continued)

To guarantee the system with no overshoot phenomenon, the resistor R1 is selected:

$$R_1 \leq \frac{1.25 \cdot L}{R8 \cdot \sqrt{2} U_{in\_rms\_max}} \cdot 10^{10} \Omega$$

In dimmable application, on the condition of the acceptable line regulation, selecting the smaller R1 will be better for dimming performance.

**Valley On Control Method**

The valley on function can provide low turn-on switching losses for buck converter. The voltage across the power switch is reflected by the auxiliary winding of the buck transformer. The voltage is sensed by FB pin.

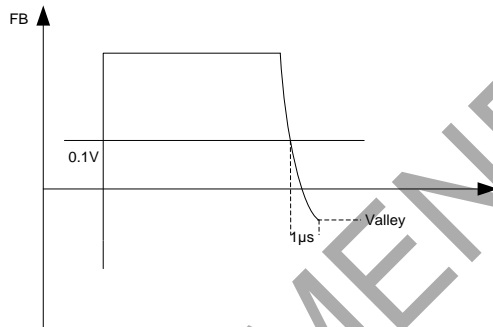

Figure 2. Valley on Control

According to Figure 2, when the falling edge of 0.1V is sensed by FB pin, the AP1695-20C will see the toff time is over and delay 1µs to start a new operating cycle. By this way we can realize valley on function.

**Passive Damping and Bleeder Design**

The passive bleeder is designed to supply latching and holding current to eliminate misfire and flicker.

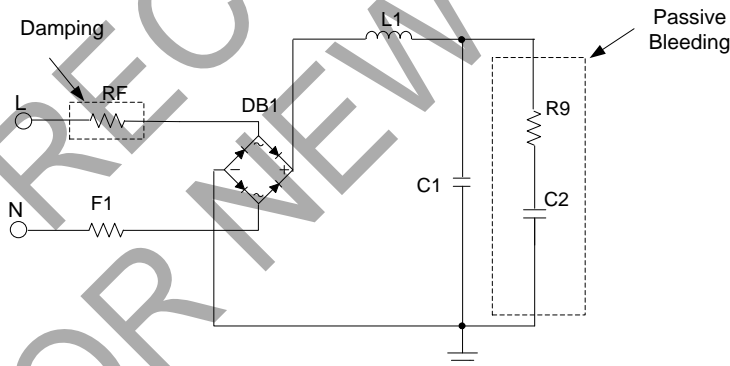

Figure 3. LED Driver Schematic with Passive Bleeder

A passive bleeder is composed of a resistor (R9) and a capacitor (C2). C1 is input filter capacitor and RF is damper resistor.

The passive bleeder includes a capacitor (C2, hundreds of nF) to provide latching current. To remove the voltage and current spike, a resistor (R9) is necessary to dampen the spike.

In dimmable application, because a large C2 will affect the PF, THD and efficiency, suitable value of the capacitor (C2) should be selected. Generally, 100nF/400V to 330nF/400V is recommended.

RF is the damper for reducing the spike current caused by quick charging of C2 at firing. RF is selected from 20Ω to 100Ω for low line application, and 51Ω to 200Ω for high line application. If R9 is too small, it cannot fully dampen the spike current and ringing current will occur. The ringing current will cause the TRIAC misfire which will cause LED flicking. Another consideration in R9 selection is power loss, too large R9 will make more power dissipation. Generally, a 200Ω to 2kΩ resistor is selected for R9.

## Application Information Based on Buck Structure (continued)

### Fault Protection

#### Over Voltage Protection and Output Open Protection

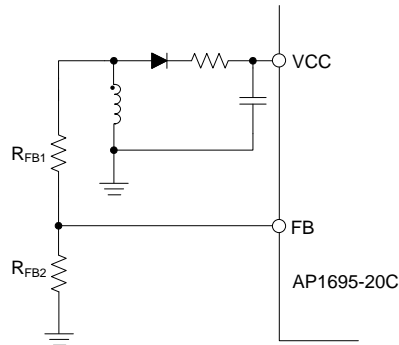

Figure 4. OVP Circuit

The output voltage is sensed by the auxiliary winding voltage of the Buck transformer, the VCC pin and FB pin provide over voltage protection function. When the output is open or large transient happens, the output voltage will exceed the rated value. When the voltage of  $V_{CC\ cap}$  exceeds  $V_{CC\_OVP}$  or  $V_{FB\_CV}$ , the over voltage is triggered and the IC will discharge  $V_{CC}$ . When the  $V_{CC}$  is below the UVLO threshold voltage, IC will start a new work cycle and the  $V_{CC\ cap}$  is charged again by start resistance. If the over voltage condition still exists, the system will work in hiccup mode.

**Attention:** If the external fast startup circuit is adding in the application and the over voltage protection and output open protection happen, the IC will trigger latch.

#### Output Short Protection

When the output is shorted, the output voltage will be clamped at 0. At this condition,  $V_{CC}$  will drop down without auxiliary winding for power supply. And the  $V_{CC}$  will drop to UVLO threshold voltage, the IC will shut down and restart a new operating cycle, and the  $V_{CC}$  is charged by startup resistance. When  $V_{CC}$  is higher than  $V_{CC\_start}$  voltage, IC will output a bunch of pulse to control power switch on and off. When still no FB signal detected, the device will not output more pulse. So the  $V_{CC}$  will drop to  $V_{CC}$  UVLO threshold again. If output short condition still exists, the system will operate in hiccup mode.

**Attention:** If the external fast startup circuit is adding in the application, the device will not work at UVLO mode, and the device will work at minimum toff mode.

#### Over Temperature Protection

AP1695-20C has two kinds of over temperature protection processes. First, the system is operating normally, the ambient temperature is changed to  $+170^{\circ}\text{C}$  suddenly, the IC will trigger over temperature protection which leads to a latch work mode. Second, if the system starts when the ambient temperature is higher than  $+150^{\circ}\text{C}$ , over temperature protection will be triggered. So the AP1695-20C can start up successfully when the ambient temperature is less than  $+150^{\circ}\text{C}$ .

#### Recommended Applications

The AP1695-20C is a device which internally integrates a MOSFET, the output current is limited by the internal integrated MOSFET, using this device can cover up to 10W's application, meanwhile the output current is less than 200mA in buck structure.

#### Components Selection Guide

If the system's spec is changed, please refer to the design sheet of the AP1695-20C and select the compatible system parameter. When the system needs to be adjusted slightly, please refer to the table below and adjust the value of the related component.

Item	Description	Related Components
$I_o$	Output current	R8
Output Current Ripple	Small current ripple is good for LED life	C4
$t_{on\_initial}$	System initial on time, used to start up the system	R1
Output Open Voltage	Setting the output voltage when the LED is open	R5, R6
Dimming Performance	Improve the dimming performance	R1, RF, R9, C2, C4
EMI	Pass EN 55022 class B with 6DB margin	L1, C1
Line Compensation	To get a good line regulation	R7

**Ordering Information**

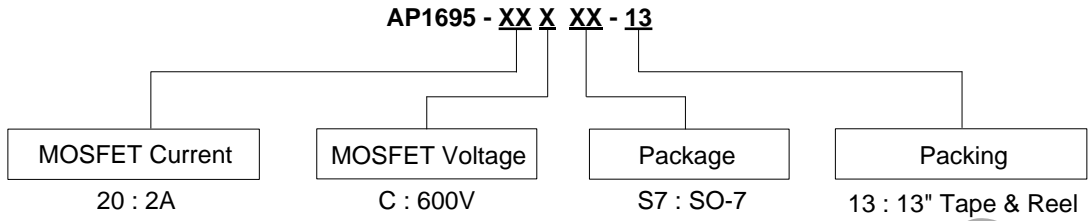

Part Number	Part Number Suffix	Package Code	Package	Packing	
				Qty.	Carrier
AP1695-20CS7-13	-13	S7	SO-7	4000	13" Tape and Reel

**Marking Information**

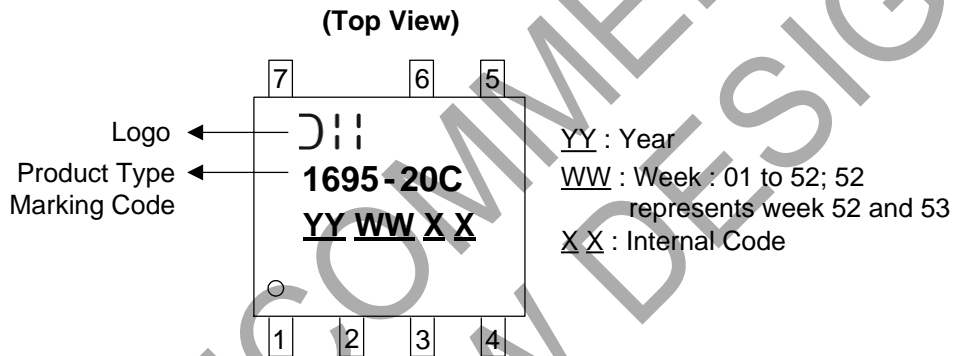

**Package Outline Dimensions** (All dimensions in mm (inch).)

Please see <http://www.diodes.com/package-outlines.html> for the latest version.

(1) Package Type: SO-7

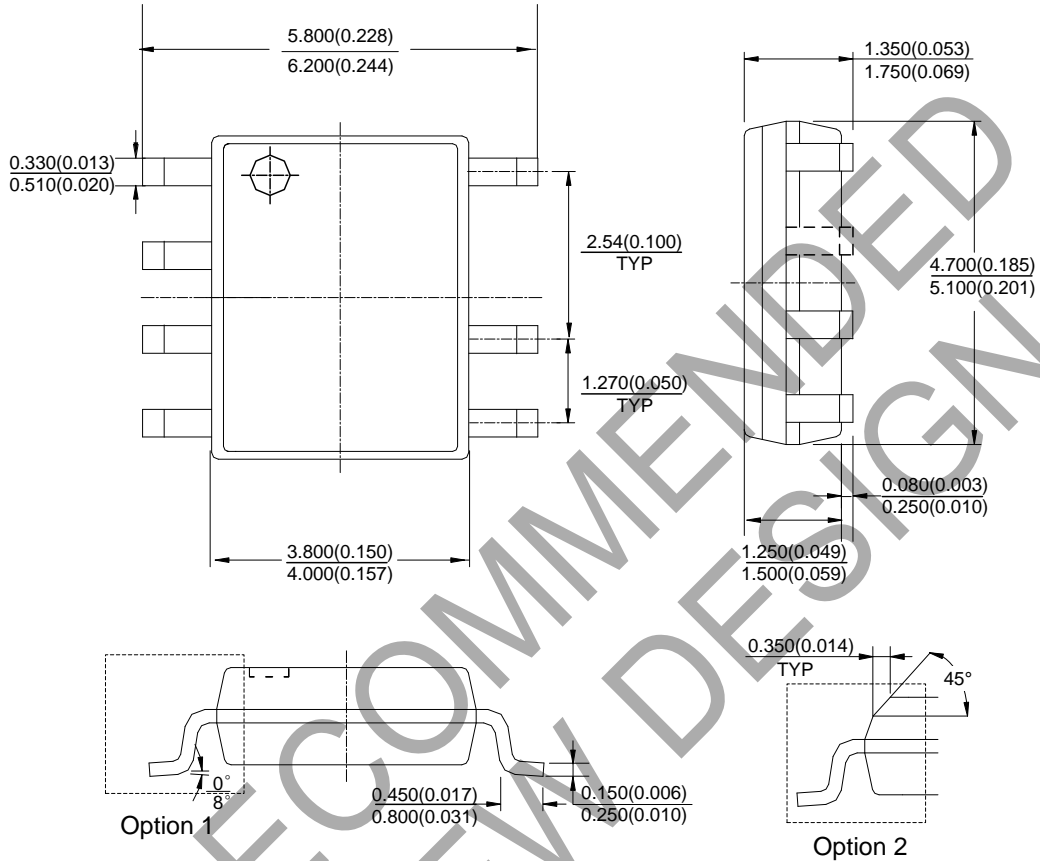

Note: Eject hole, oriented hole and mold mark is optional.

NOT RECOMMENDED FOR NEW DESIGN

**Suggested Pad Layout**

Please see <http://www.diodes.com/package-outlines.html> for the latest version.

(1) Package Type: SO-7

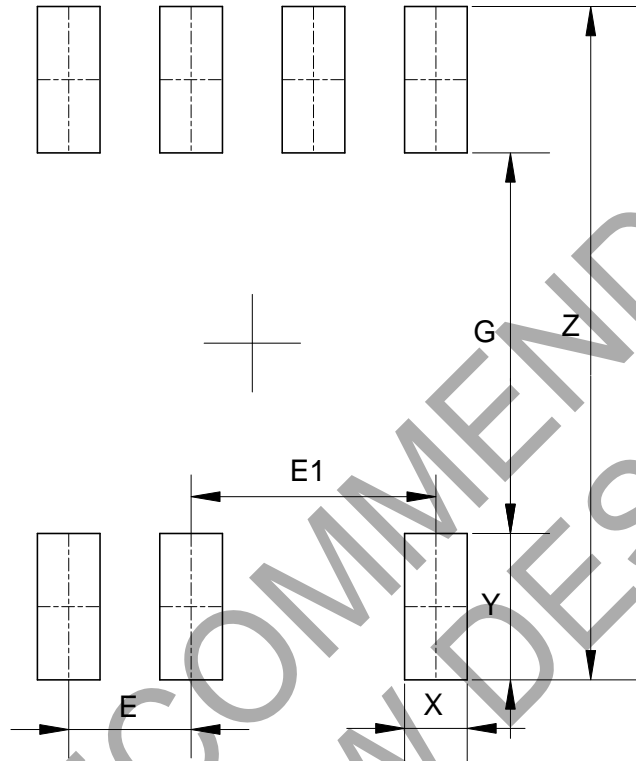

Dimensions	Z (mm)/(inch)	G (mm)/(inch)	X (mm)/(inch)	Y (mm)/(inch)	E (mm)/(inch)	E1 (mm)/(inch)
Value	6.900/0.272	3.900/0.154	0.650/0.026	1.500/0.059	1.270/0.050	2.540/0.100

NOT RECOMMENDED FOR NEW DESIGN

**IMPORTANT NOTICE**

1. DIODES INCORPORATED (Diodes) AND ITS SUBSIDIARIES MAKE NO WARRANTY OF ANY KIND, EXPRESS OR IMPLIED, WITH REGARDS TO ANY INFORMATION CONTAINED IN THIS DOCUMENT, INCLUDING, BUT NOT LIMITED TO, THE IMPLIED WARRANTIES OF MERCHANTABILITY, FITNESS FOR A PARTICULAR PURPOSE OR NON-INFRINGEMENT OF THIRD PARTY INTELLECTUAL PROPERTY RIGHTS (AND THEIR EQUIVALENTS UNDER THE LAWS OF ANY JURISDICTION).
2. The Information contained herein is for informational purpose only and is provided only to illustrate the operation of Diodes' products described herein and application examples. Diodes does not assume any liability arising out of the application or use of this document or any product described herein. This document is intended for skilled and technically trained engineering customers and users who design with Diodes' products. Diodes' products may be used to facilitate safety-related applications; however, in all instances customers and users are responsible for (a) selecting the appropriate Diodes products for their applications, (b) evaluating the suitability of Diodes' products for their intended applications, (c) ensuring their applications, which incorporate Diodes' products, comply the applicable legal and regulatory requirements as well as safety and functional-safety related standards, and (d) ensuring they design with appropriate safeguards (including testing, validation, quality control techniques, redundancy, malfunction prevention, and appropriate treatment for aging degradation) to minimize the risks associated with their applications.
3. Diodes assumes no liability for any application-related information, support, assistance or feedback that may be provided by Diodes from time to time. Any customer or user of this document or products described herein will assume all risks and liabilities associated with such use, and will hold Diodes and all companies whose products are represented herein or on Diodes' websites, harmless against all damages and liabilities.
4. Products described herein may be covered by one or more United States, international or foreign patents and pending patent applications. Product names and markings noted herein may also be covered by one or more United States, international or foreign trademarks and trademark applications. Diodes does not convey any license under any of its intellectual property rights or the rights of any third parties (including third parties whose products and services may be described in this document or on Diodes' website) under this document.
5. Diodes' products are provided subject to Diodes' Standard Terms and Conditions of Sale (<https://www.diodes.com/about/company/terms-and-conditions/terms-and-conditions-of-sales/>) or other applicable terms. This document does not alter or expand the applicable warranties provided by Diodes. Diodes does not warrant or accept any liability whatsoever in respect of any products purchased through unauthorized sales channel.
6. Diodes' products and technology may not be used for or incorporated into any products or systems whose manufacture, use or sale is prohibited under any applicable laws and regulations. Should customers or users use Diodes' products in contravention of any applicable laws or regulations, or for any unintended or unauthorized application, customers and users will (a) be solely responsible for any damages, losses or penalties arising in connection therewith or as a result thereof, and (b) indemnify and hold Diodes and its representatives and agents harmless against any and all claims, damages, expenses, and attorney fees arising out of, directly or indirectly, any claim relating to any noncompliance with the applicable laws and regulations, as well as any unintended or unauthorized application.
7. While efforts have been made to ensure the information contained in this document is accurate, complete and current, it may contain technical inaccuracies, omissions and typographical errors. Diodes does not warrant that information contained in this document is error-free and Diodes is under no obligation to update or otherwise correct this information. Notwithstanding the foregoing, Diodes reserves the right to make modifications, enhancements, improvements, corrections or other changes without further notice to this document and any product described herein. This document is written in English but may be translated into multiple languages for reference. Only the English version of this document is the final and determinative format released by Diodes.
8. Any unauthorized copying, modification, distribution, transmission, display or other use of this document (or any portion hereof) is prohibited. Diodes assumes no responsibility for any losses incurred by the customers or users or any third parties arising from any such unauthorized use.
9. This Notice may be periodically updated with the most recent version available at <https://www.diodes.com/about/company/terms-and-conditions/important-notice>

DIODES is a trademark of Diodes Incorporated in the United States and other countries.  
The Diodes logo is a registered trademark of Diodes Incorporated in the United States and other countries.  
© 2022 Diodes Incorporated. All Rights Reserved.

[www.diodes.com](http://www.diodes.com)