

## Features

- PWM Buck Control Circuitry
- Operating voltage can be up to 20V
- Under voltage Lockout (UVLO) Protection
- Short Circuit Protection (SCP)
- Soft-start circuit
- Variable Oscillator Frequency -- 300Khz Max
- 0.77V voltage reference Output
- 8-pin SOP package
- SOP-8L: Available in "Green" Molding Compound (No Br, Sb)
- Lead Free Finish/ RoHS Compliant (Note 1)

## General Description

The AP2008 integrates Pulse-Width-Modulation (PWM) control circuit into a single chip, mainly designs for power-supply regulator. All the functions include an on-chip 0.77V reference output, an error amplifier, an adjustable oscillator, a soft-start, UVLO, SCP circuitry, and a push-pull output circuit. Switching frequency is adjustable by trimming CT. During low VCC situation, the UVLO makes sure that the outputs are off until the internal circuit is operational normally.

## Applications

- Backlight inverter
- LCD Monitor
- XDRom, XDSL Product
- DC/DC converters in computers, etc.

## Ordering Information

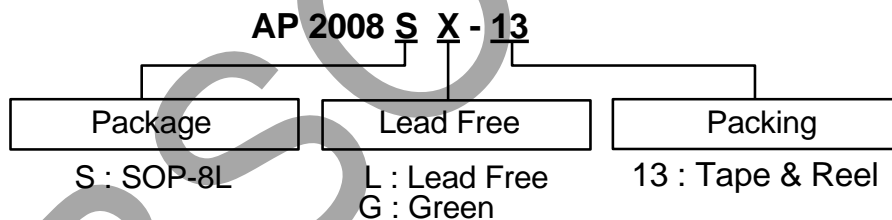

Device	Package Code	Packaging (Note 2)	13" Tape and Reel	
			Quantity	Part Number Suffix
AP2008SL-13	S	SOP-8L	2500/Tape & Reel	-13
AP2008SG-13	S	SOP-8L	2500/Tape & Reel	-13

- Notes:
1. EU Directive 2002/95/EC (RoHS). All applicable RoHS exemptions applied. Please visit our website at [http://www.diodes.com/products/lead\\_free.html](http://www.diodes.com/products/lead_free.html).
  2. Pad layout as shown on Diodes Inc. suggested pad layout document AP02001, which can be found on our website at <http://www.diodes.com/datasheets/ap02001.pdf>.

## Pin Assignments

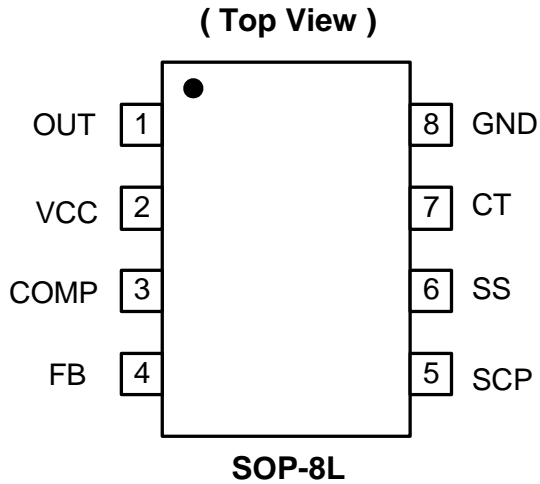

## Pin Descriptions

Pin Name	Description
OUT	PWM Output
VCC	Supply Voltage
COMP	Feedback Loop Compensation
FB	Voltage Feedback
SCP	Short Circuit Protection
SS	Soft-Start.
CT	Timing Capacitor
GND	Ground

**Block Diagram**

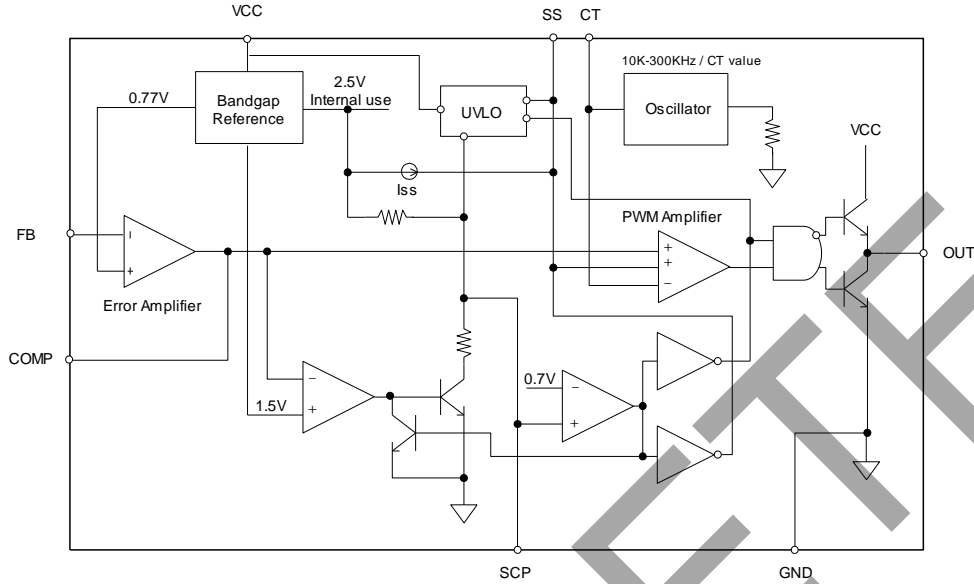

**Absolute Maximum Ratings**

Symbol	Parameter	Rating	Unit
$V_{CC}$	Supply voltage	22	V
$V_I$	Amplifier input voltage	20	V
$V_O$	Collector output voltage	$V_{CC}-1.0V$	V
$I_{SOURCE}$	Source current	200	mA
$I_{SINK}$	Sink current	200	mA
$T_{OP}$	Operating temperature range	-20 to +85	°C
$T_{ST}$	Storage temperature range	-65 to +150	°C

**Recommended Operating Conditions**

Symbol	Parameter	Min	Max	Unit
$V_{CC}$	Supply voltage	3.6	20	V
$V_I$	Amplifier input voltage	1.05	1.45	V
$V_O$	Collector output voltage		$V_{CC}-1.5$	V
$I_{FB}$	Current into feedback terminal		45	μA
$R_F$	Feedback resistor	100		kΩ
$C_T$	Timing capacitor	100	6800	pF
$F_{OSC}$	Oscillator frequency	10	300	KHz

**Electrical Characteristics** ( $T_A=25^{\circ}\text{C}$ ,  $V_{CC}=6\text{V}$ ,  $f=200\text{ KHz}$ )

**Reference (REF)**

Symbol	Parameter	Conditions	Min	Typ.	Max	Unit
$V_{REF}$	Comp connect to FB		0.755	0.770	0.785	V
	Output voltage change with temperature	$T_A = -20^{\circ}\text{C} \sim 25^{\circ}\text{C}$		-0.1	$\pm 1$	%
		$T_A = 25^{\circ}\text{C} \sim 85^{\circ}\text{C}$			-0.2	$\pm 1$

**Under voltage lockout (UVLO)**

Symbol	Parameter	Conditions	Min	Typ.	Max	Unit
$V_{UT}$	Upper threshold voltage ( $V_{CC}$ )	$I_{O(REF)} = 0.1\text{mA}$ $T_A = 25^{\circ}\text{C}$		2.9		V
$V_{LWT}$	Lower threshold voltage ( $V_{CC}$ )			2.4		V
$V_{HT}$	Hysteresis ( $V_{CC}$ )				500	mV

**Short-circuit protection (SCP) control**

Symbol	Parameter	Conditions	Min	Typ.	Max	Unit
$V_{IT}$	Input threshold voltage	$T_A = 25^{\circ}\text{C}$	0.60	0.67	0.75	V
$V_{STB}$	Standby voltage	No pull up	100	130	160	mV
$V_{LT}$	Latched input voltage	No pull up		50	100	mV
$I_{SCP}$	Input (source) current	$V_I = 0.7\text{V}$ , $T_A = 25^{\circ}\text{C}$	-10	-15	-20	$\mu\text{A}$
$V_{CT}$	Comparator threshold voltage (COMP)			1.5		V

**Oscillator (OSC)**

Symbol	Parameter	Conditions	Min	Typ.	Max	Unit
$F_{OSC}$	Frequency	$C_T = 270\text{ pF}$		200		KHz
$\Delta F_{OSC}$	Standard deviation of frequency	$C_T = 270\text{ pF}$		10		%
	Frequency change with voltage	$V_{CC} = 3.6\text{V} \sim 20\text{V}$		1		

**Error-amplifier**

Symbol	Parameter	Conditions	Min	Typ.	Max	Unit
$V_{IO}$	Input offset voltage	$V_O(\text{FB}) = 0.77\text{V}$			$\pm 6$	mV
$I_{IO}$	Input offset current	$V_O(\text{FB}) = 0.77\text{V}$			$\pm 100$	nA
$I_{IB}$	Input bias current	$V_O(\text{FB}) = 0.77\text{V}$		160	500	nA
$V_{CM}$	Common-mode input voltage range	$V_{CC} = 3.6\text{V} \sim 20\text{V}$	1.05		1.45	V
AV	Open-loop voltage amplification	$R_F = 200\text{ k}\Omega$	70	80		dB
GBW	Unity-gain bandwidth			1.5		MHz
CMRR	Common-mode rejection ratio		60	80		dB
$V_{OH}$	Max. output voltage		$V_{ref} - 0.1$			V
$V_{OL}$	Min. output voltage				1	V
$I_{OI}$	Output (sink) current (COMP)	$V_{ID} = -0.1\text{V}$ , $V_O = 0.77\text{V}$	0.5	1.6		mA
$I_{OO}$	Output (source) current (COMP)	$V_{ID} = 0.1\text{V}$ , $V_O = 0.77\text{V}$	-45	-70		$\mu\text{A}$

**Electrical Characteristics** (Continued) ( $T_A=25^{\circ}\text{C}$ ,  $V_{CC}=6\text{V}$ ,  $f=200\text{ KHz}$ )

**Output section**

Symbol	Parameter	Conditions	Min	Typ.	Max	Unit
$I_{LEAK}$	Leakage current	$V_O = 20\text{V}$			10	$\mu\text{A}$
$I_{DRV}$	Sink current	$V_{IN} = 12\text{V}$		200		$\text{mA}$
	Source current	$V_{IN} = 12\text{V}$		200		$\text{mA}$
$V_{SAT}$	Output saturation voltage	$I_O = 10\text{ mA}$		1.0	1.5	$\text{V}$
$I_{SC}$	Short-circuit output current	$V_O = 6\text{V}$		120		$\text{mA}$

**PWM comparator**

Symbol	Parameter	Conditions	Min	Typ.	Max	Unit
$V_{T0}$	Input threshold voltage at $f = 10\text{ KHz}$ (COMP)	$C_T = 6800\text{pF}$		0.6	0.7	$\text{V}$
$V_{T100}$		Maximum duty cycle		1.2	1.3	$\text{V}$

**Total device**

Symbol	Parameter	Conditions	Min	Typ.	Max	Unit
$I_{CCA}$	Average supply current	$C_T = 270\text{pF}$		6	10	$\text{mA}$

**Soft Start**

Symbol	Parameter	Conditions	Min	Typ.	Max	Unit
$V_{SS}$	Soft-start Voltage			2.3		$\text{V}$
$I_{SS}$	Constant Charge Current			20		$\mu\text{A}$

**Typical Application Circuit**

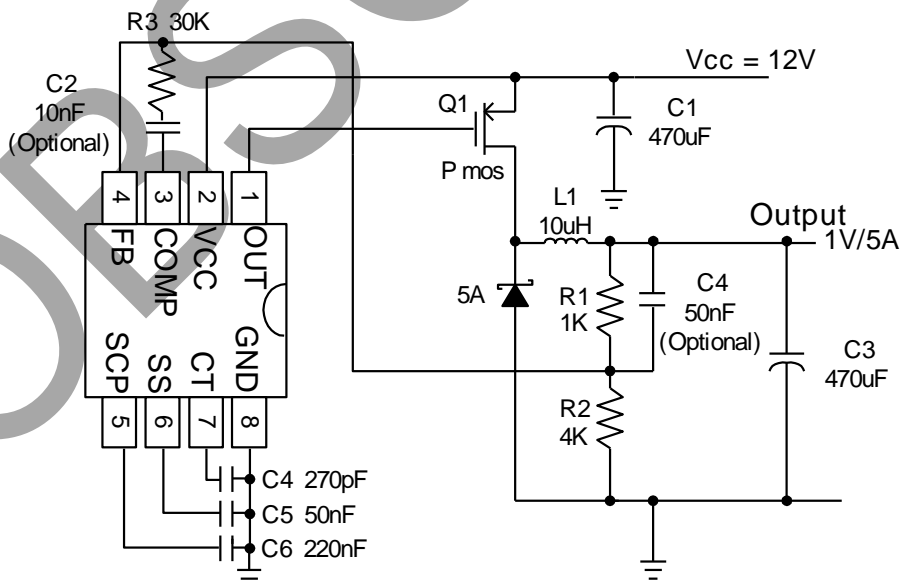

**Step-Down DC/DC converter**

**Typical Characteristics**

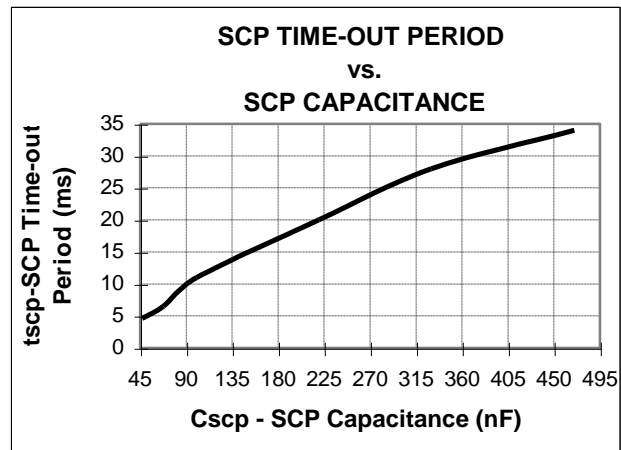
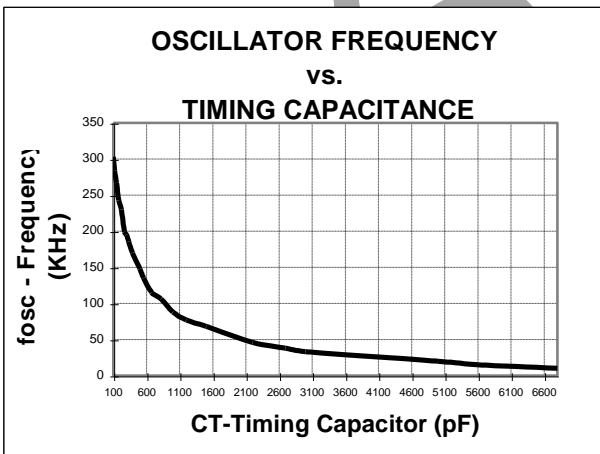
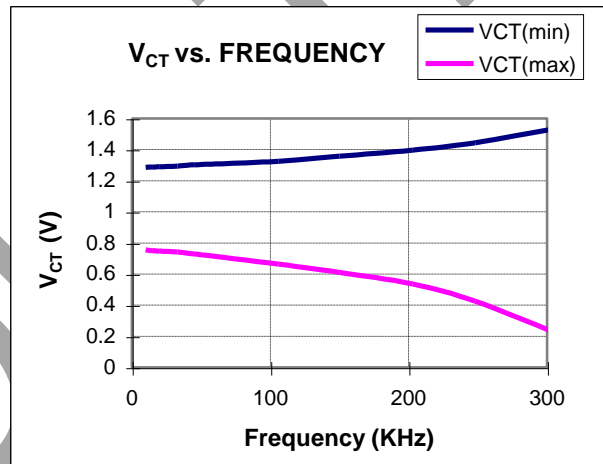
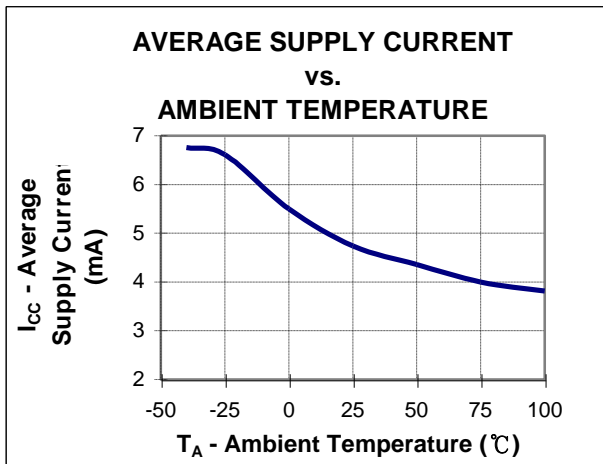
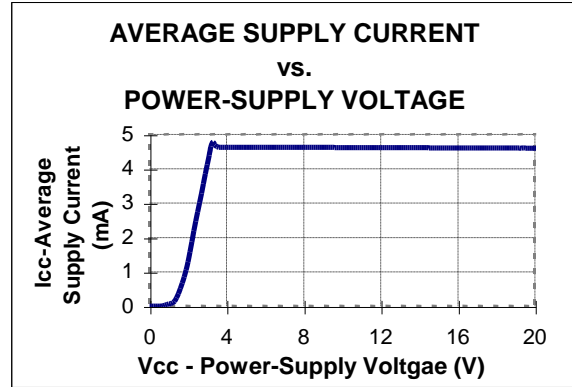
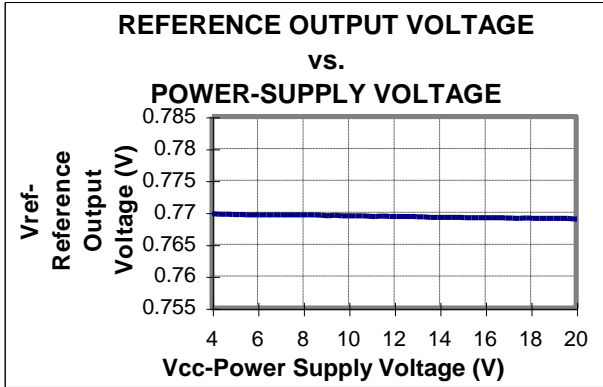

**Typical Characteristics (Continued)**

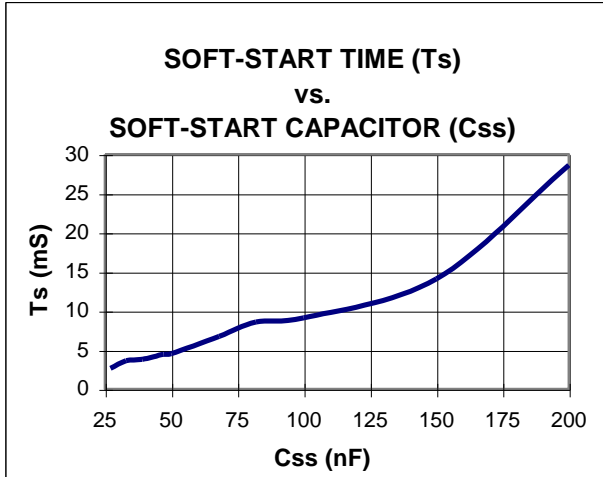

**Marking Information**

(1) SOP-8L

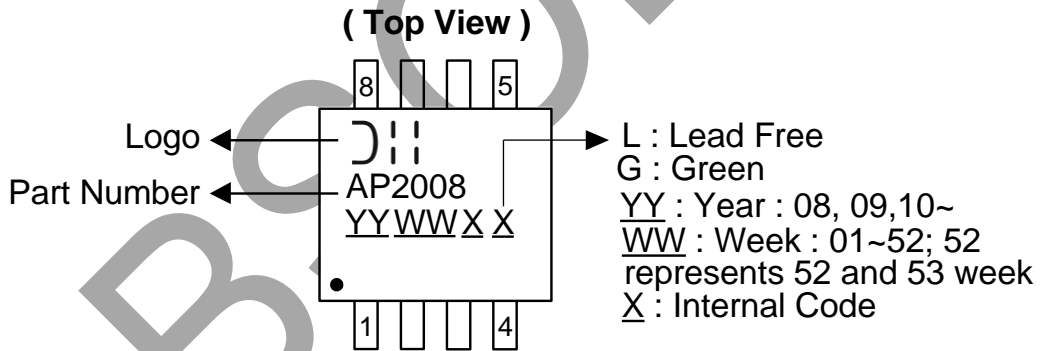

**Package Information (All Dimensions in mm)**

**(1) Package Type: SOP- 8L**

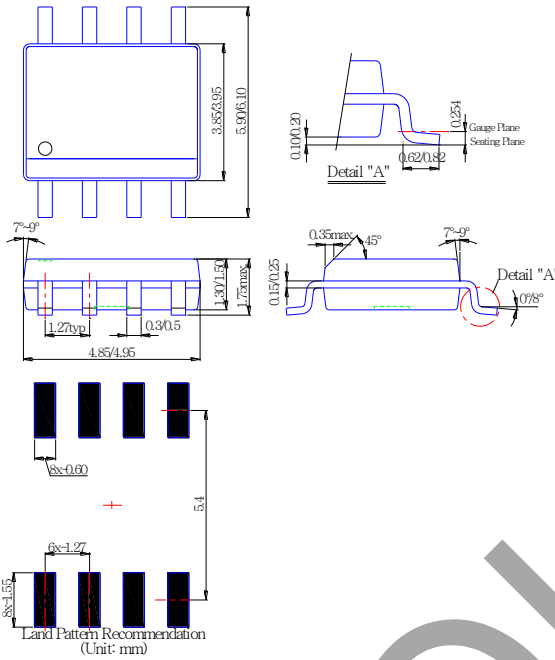

**IMPORTANT NOTICE**

Diodes Incorporated and its subsidiaries reserve the right to make modifications, enhancements, improvements, corrections or other changes without further notice to any product herein. Diodes Incorporated does not assume any liability arising out of the application or use of any product described herein; neither does it convey any license under its patent rights, nor the rights of others. The user of products in such applications shall assume all risks of such use and will agree to hold Diodes Incorporated and all the companies whose products are represented on our website, harmless against all damages.

**LIFE SUPPORT**

Diodes Incorporated products are not authorized for use as critical components in life support devices or systems without the expressed written approval of the President of Diodes Incorporated.