

Description

The AP2318 is a series of ultra low dropout regulators optimized for low voltage applications where transient response and minimum input voltage are critical.

The AP2318 provides current limit and thermal shutdown. Its circuit includes a trimmed bandgap reference to assure output voltage accuracy to be within $\pm 1.5\%$. On-chip thermal shutdown provides protection against any combination of overload and ambient temperatures that would create excessive junction temperatures.

The AP2318 has both fixed and adjustable versions. The 1.3V fixed versions integrate the corresponding resistor divider. The adjustable version can set the output voltage through two external resistors.

The AP2318 is available in the standard DFN-3x3-8 and SOIC-8 packages.

Features

- Wide Operating Voltage Ranges: 2.5V to 12V
- Output Voltage Accuracy: $\pm 1.5\%$
- On-chip Thermal Shutdown
- ESD
 - Human Body Model 3kV
 - Machine Model 600V
- Operating Junction Temperature: -40°C to $+125^{\circ}\text{C}$

Pin Assignments

(Top View)

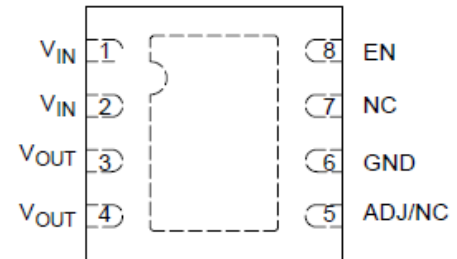

DFN-3x3-8

(Top View)

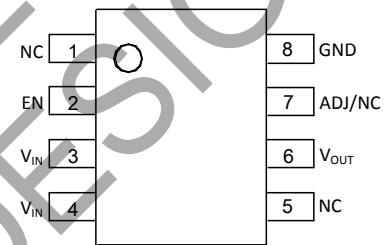

SOIC-8

Applications

- Notebook
- USB Device
- Add-on Card
- DVD Player
- PC Motherboard

Typical Applications Circuit

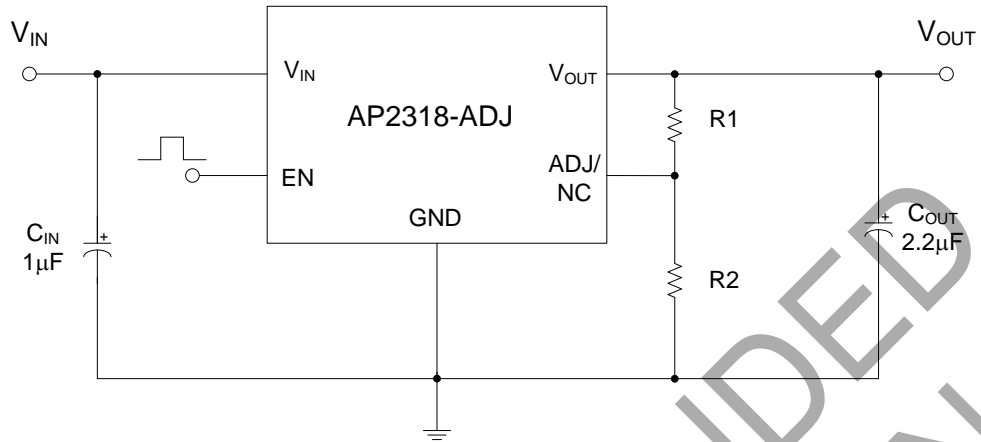

ADJ Version, $V_{OUT} = 0.8 \cdot (R1+R2)/R2$

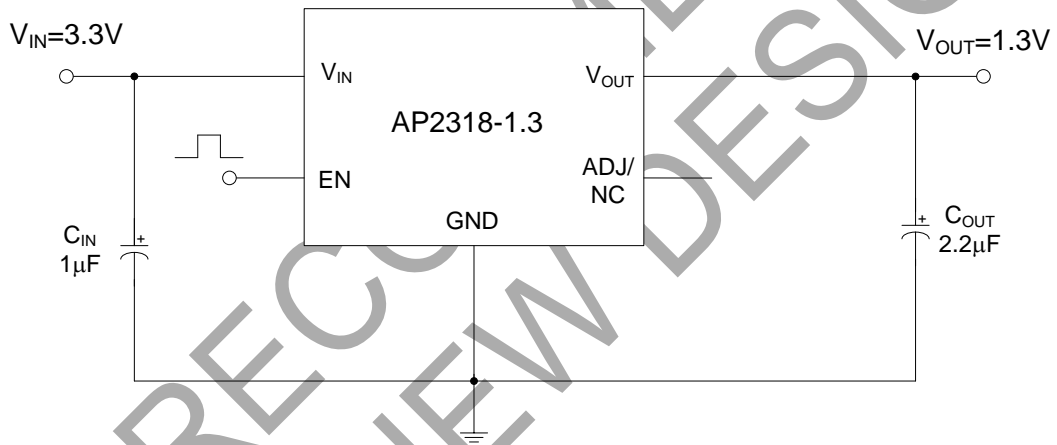

Fixed 1.3V Version, $V_{OUT} = 1.3V$

Pin Description

Pin Number		Pin Name	Function
DFN-3x3-8	SOIC-8		
1, 2	3, 4	V _{IN}	Input Voltage
3, 4	6	V _{OUT}	Output Voltage
5	7	ADJ/NC	Adjust Voltage/No Connection
6	8	GND	Ground
7	1, 5	NC	No Connection
8	2	EN	On/Off Control

Recommended Operating Conditions

Symbol	Parameter	Min	Max	Unit
V_{IN}	Input Voltage	2.5	12	V
V_{EN}	Enable Voltage	—	12	V
T_J	Operating Junction Temperature Range	-40	+125	°C

Electrical Characteristics (Operating Conditions: $2.5V \leq V_{IN} \leq 12V$, $C_{IN} = 1\mu F$, $C_{OUT} = 2.2\mu F$, $T_J = +25^\circ C$, unless otherwise specified. ($P \leq$ Maximum Power Dissipation). Limits appearing in **Boldface** type apply over the entire junction temperature range for operation of -40°C to +125°C.)

Symbol	Parameter	Conditions	Min	Typ	Max	Unit
V_{REF}	Reference Voltage	AP2318-ADJ $I_{OUT} = 10mA$, $V_{IN} - V_{OUT} = 2V$, $T_J = +25^\circ C$ $10mA \leq I_{OUT} \leq 600mA$, $V_{OUT} + 2V \leq V_{IN} \leq 12V$	0.788 0.784	0.800 0.800	0.812 0.816	V
V_{OUT}	Output Voltage	$I_{OUT} = 10mA$, $V_{IN} = 2.5V$, $T_J = +25^\circ C$ $10mA \leq I_{OUT} \leq 600mA$, $2.5V \leq V_{IN} \leq 12V$	-1.5% -2%	—	1.5% 2%	V
$I_{OUT(max)}$	Maximum Output Current	$V_{IN} - V_{OUT} = 2V$	0.85	1.2	—	A
V_{RLINE}	Line Regulation	AP2318-ADJ $I_{OUT} = 10mA$, $V_{OUT} + 2V \leq V_{IN} \leq 12V$	—	1	6	mV
		$I_{OUT} = 10mA$, $2.5V \leq V_{IN} \leq 12V$	—	1	6	mV
V_{RLOAD}	Load Regulation	AP2318-ADJ $V_{IN} = V_{OUT} + 2V$, $10mA \leq I_{OUT} \leq 600mA$	—	1	10	mV
		$V_{IN} = 2.5V$, $10mA \leq I_{OUT} \leq 600mA$	—	1	10	mV
V_{DROP}	Dropout Voltage	$\Delta V_{OUT} (\Delta V_{REF}) = 1%$, $I_{OUT} = 600mA$	—	0.35	—	V
I_{ADJ}	Adjust Pin Current	—	—	0.05	1	μA
$I_{LOAD(min)}$	Minimum Load Current	$V_{OUT} + 2V \leq V_{IN} \leq 12V$ (ADJ only)	—	1.7	5	mA
I_Q	Quiescent Current	$V_{IN} = V_{OUT} + 2V$, $I_{OUT} = 0mA$	—	250	—	μA
V_{NOI}	RMS Output Noise (% of V_{OUT})	$T_A = +25^\circ C$, $10Hz \leq f \leq 20kHz$	—	0.003	—	%
—	Thermal Shutdown Temperature	—	—	+150	—	°C
—	Thermal Shutdown Hysteresis	—	—	+25	—	°C
V_{EN}	Enable Input Voltage	Enable Logic Low	—	—	0.8	V
		Enable Logic High	2.25	—	—	
I_{EN}	Enable Input Current	$V_{EN} = 2.25V$	—	5	15	μA
		$V_{EN} = 0.8V$	—	—	4	μA
θ_{JC}	Thermal Resistance (Junction to Case)	DFN-3x3-8	—	15	—	°C/W
		SOIC-8	—	24	—	

Performance Characteristics

Output Voltage vs. Output Current
(Conditions: $V_{OUT} = 0.8V$, ADJ Short to GND)

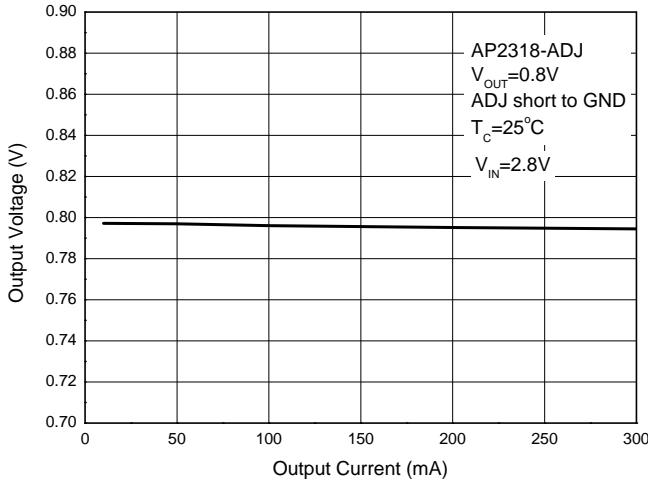

Output Voltage vs. Output Current
(Conditions: $V_{OUT} = 1.2V$, $R1 = 3k\Omega$, $R2 = 6.2k\Omega$)

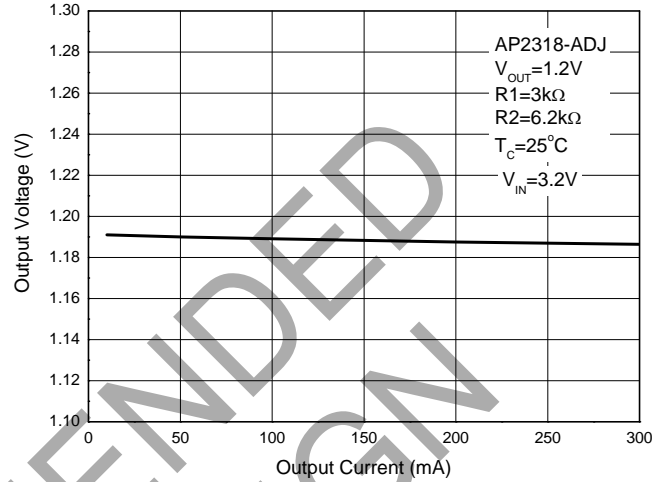

Output Voltage vs. Output Current
(Conditions: $V_{OUT} = 0.8V$, ADJ Short to GND)

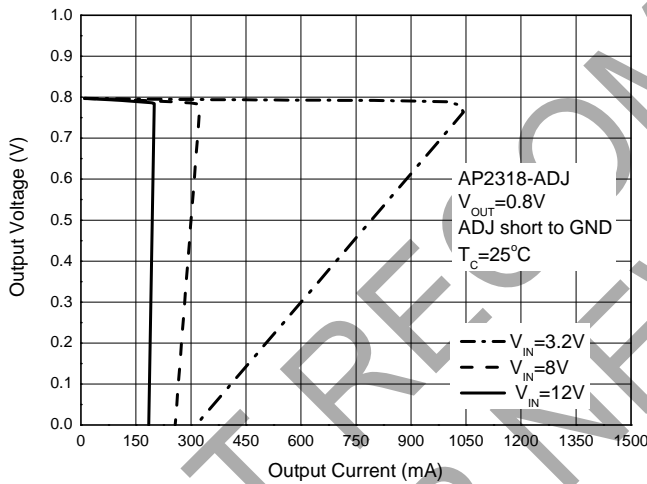

Output Voltage vs. Output Current
(Conditions: $V_{OUT} = 1.2V$, $R1 = 3k\Omega$, $R2 = 6.2k\Omega$)

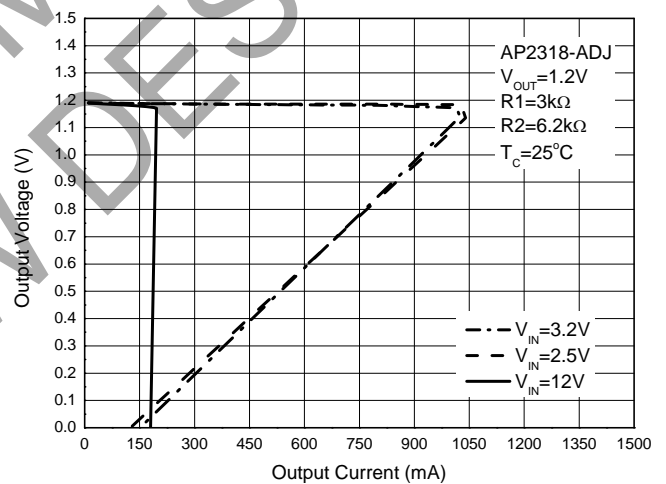

Output Voltage vs. Output Current
(Conditions: $V_{OUT} = 0.8V$, ADJ Short to GND)

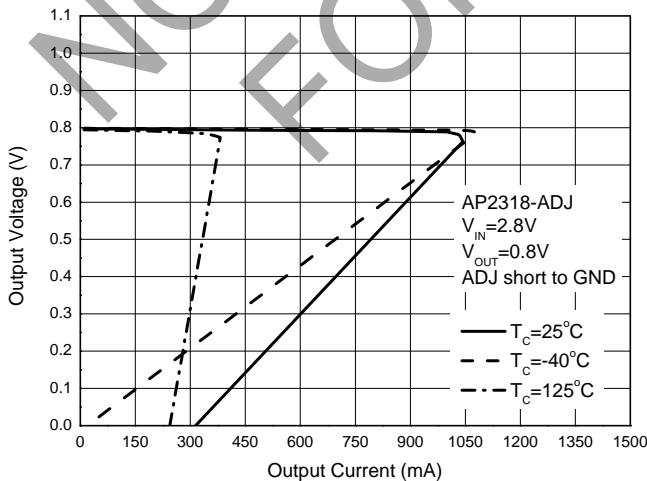

Output Voltage vs. Output Current
(Conditions: $V_{OUT} = 1.2V$, $R1 = 3k\Omega$, $R2 = 6.2k\Omega$)

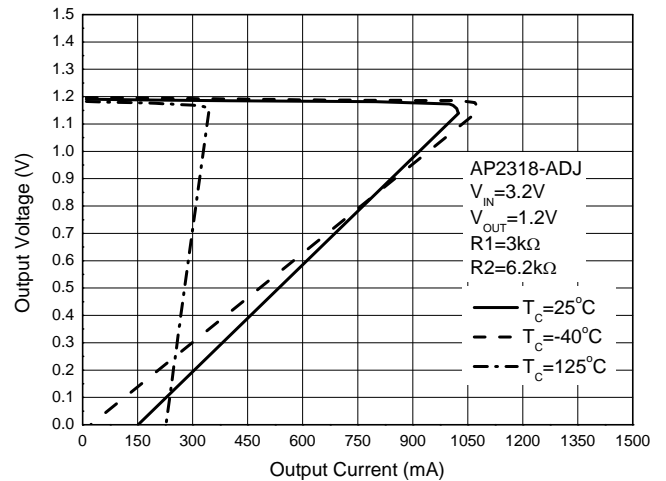

Performance Characteristics (Cont.)

Output Voltage vs. Input Voltage
(Conditions: $V_{OUT} = 0.8V$, ADJ Short to GND)

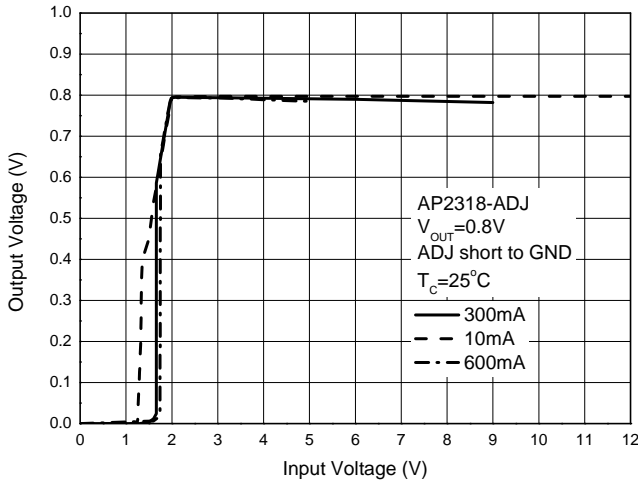

Output Voltage vs. Input Voltage
(Conditions: $V_{OUT} = 1.2V$, $R1 = 3k\Omega$, $R2 = 6.2k\Omega$)

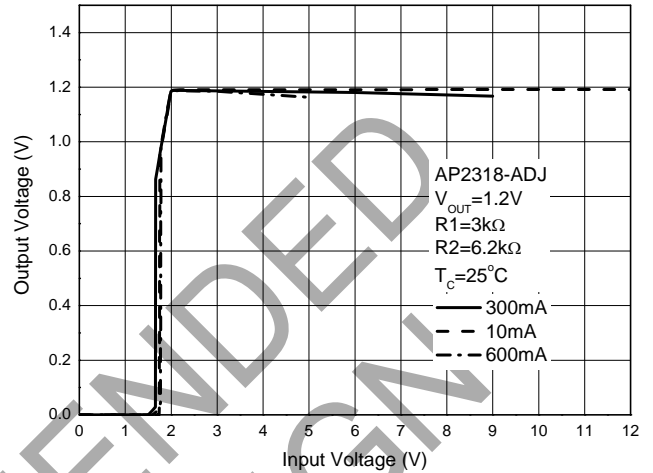

Output Voltage vs. Case Temperature
(Conditions: $V_{OUT} = 0.8V$, ADJ Short to GND)

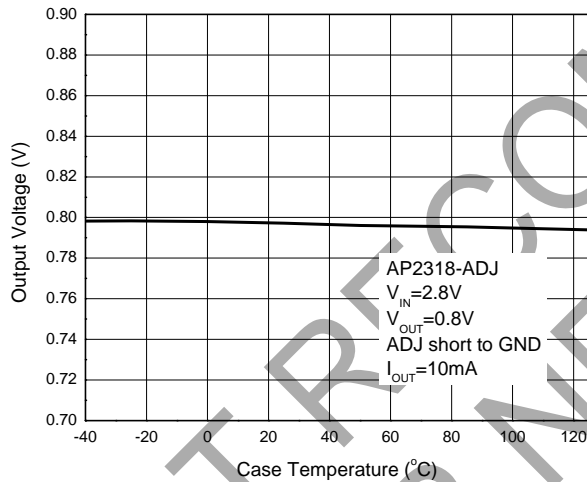

Output Voltage vs. Case Temperature
(Conditions: $V_{OUT} = 1.2V$, $R1 = 3k\Omega$, $R2 = 6.2k\Omega$)

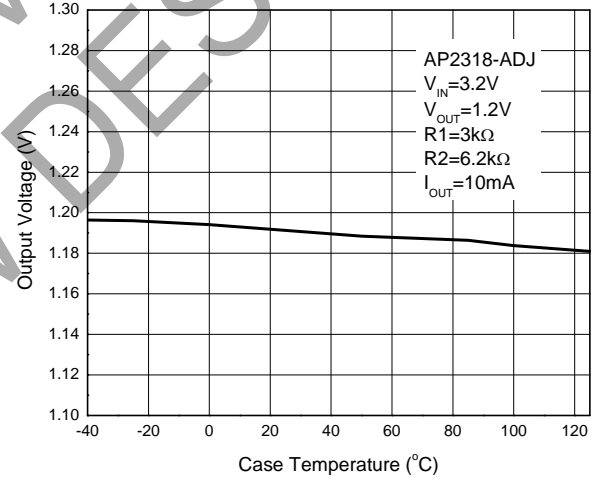

Supply Current vs. Input Voltage
(Conditions: $V_{OUT} = 0.8V$, ADJ Short to GND)

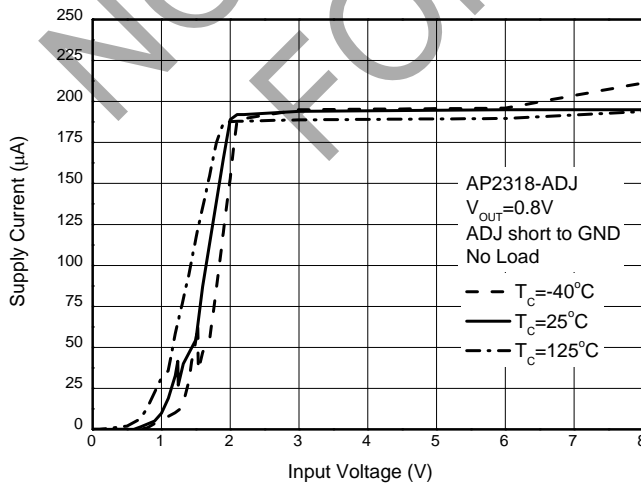

Supply Current vs. Input Voltage
(Conditions: $V_{OUT} = 1.2V$, $R1 = 3k\Omega$, $R2 = 6.2k\Omega$)

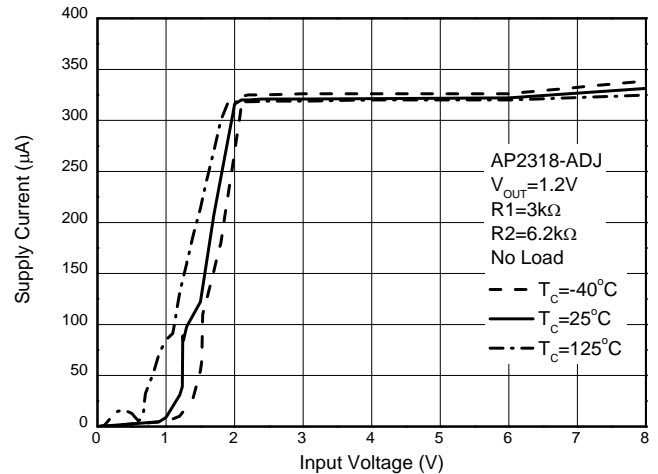

Performance Characteristics (Cont.)

Supply Current vs. Case Temperature
(Conditions: $V_{OUT} = 0.8V$, ADJ Short to GND)

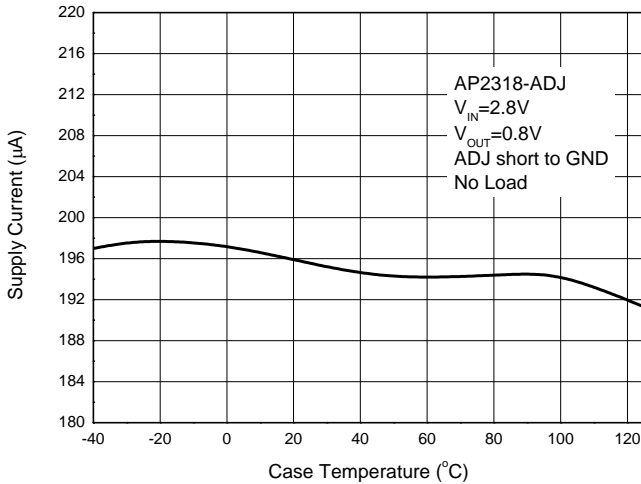

Supply Current vs. Case Temperature
(Conditions: $V_{OUT} = 1.2V$, $R1 = 3k\Omega$, $R2 = 6.2k\Omega$)

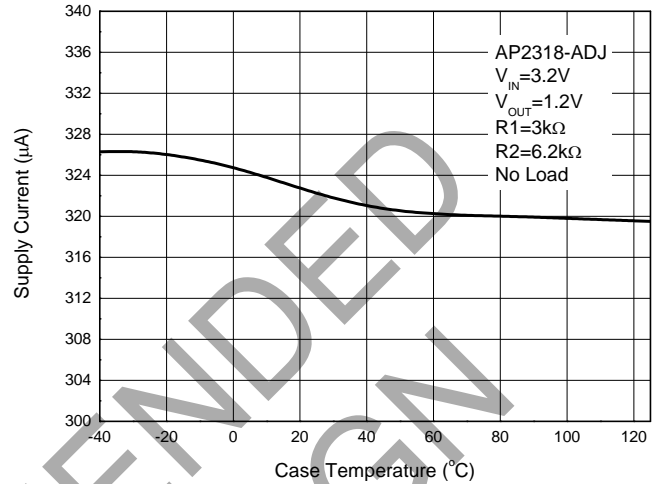

Supply Current vs. Output Current
(Conditions: $V_{OUT} = 0.8V$, ADJ Short to GND)

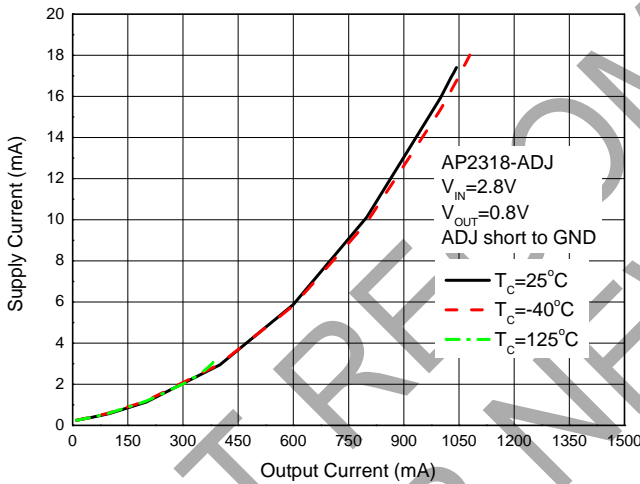

Supply Current vs. Output Current
(Conditions: $V_{OUT} = 1.2V$, $R1 = 3k\Omega$, $R2 = 6.2k\Omega$)

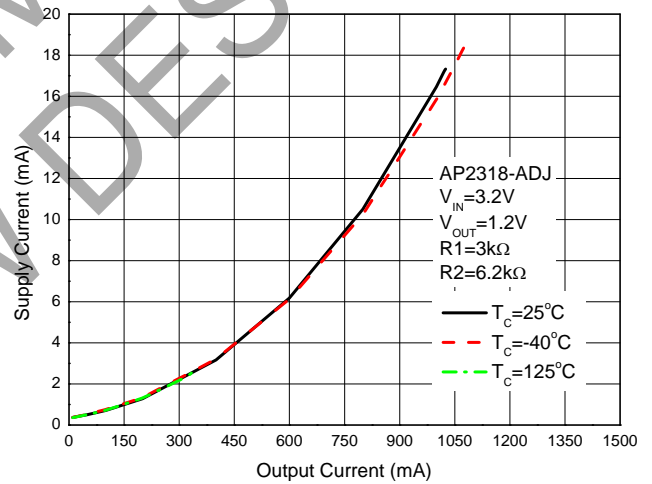

Supply Current vs. Output Current
(Conditions: $V_{OUT} = 0.8V$, ADJ Short to GND)

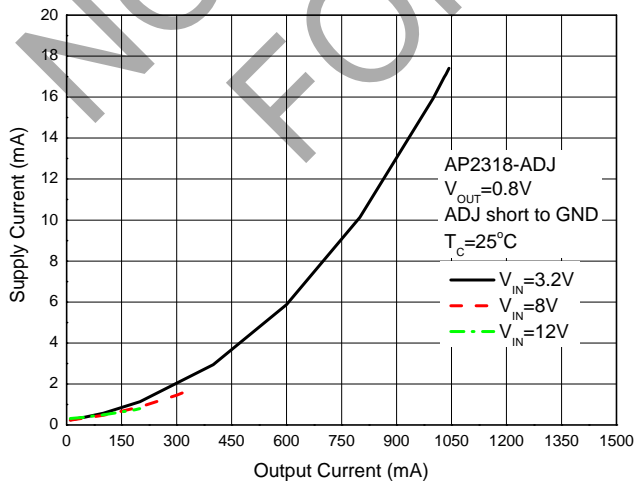

Supply Current vs. Output Current
(Conditions: $V_{OUT} = 1.2V$, $R1 = 3k\Omega$, $R2 = 6.2k\Omega$)

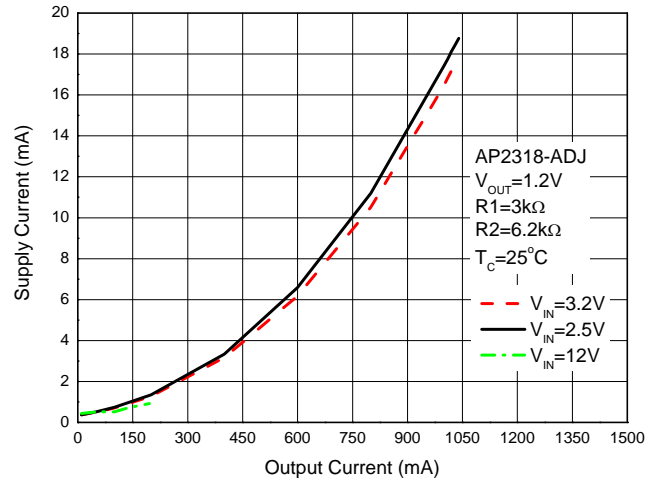

Performance Characteristics (Cont.)

Load Transient Response

(Conditions: $V_{IN} = 2.5V$, $V_{OUT} = 1.3V$, $I_{OUT} = 1mA$ to $300mA$,
 $C_{IN} = 1\mu F$, $C_{OUT} = 2.2\mu F$)

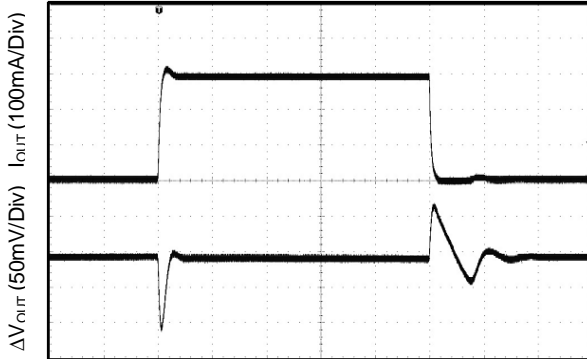

Time (200μs/Div)

Load Transient Response

(Conditions: $V_{IN} = 2.5V$, $V_{OUT} = 1.8V$, $I_{OUT} = 1mA$ to $600mA$,
 $C_{IN} = 1\mu F$, $C_{OUT} = 2.2\mu F$)

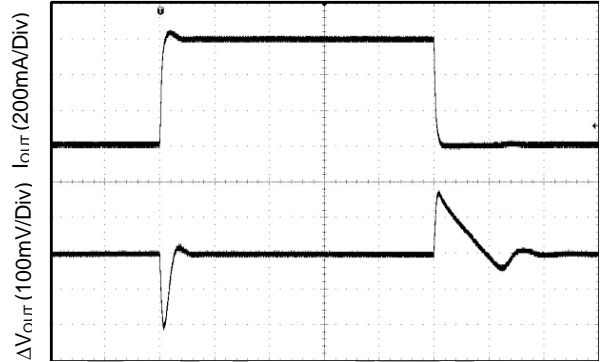

Time (200μs/Div)

Line Transient Response

(Conditions: $V_{IN} = 2.5V$ to $5V$, $V_{OUT} = 0.8V$, $I_{OUT} = 10mA$,
 $C_{IN} = 0\mu F$, $C_{OUT} = 2.2\mu F$)

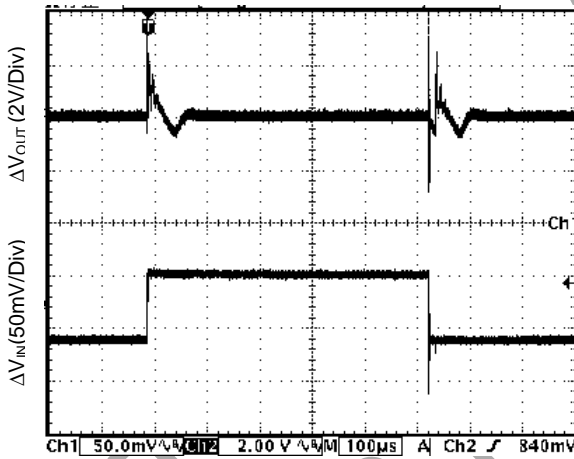

PSRR vs. Frequency

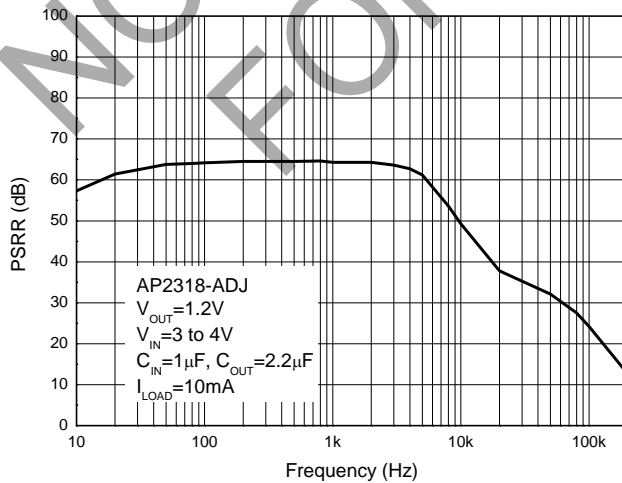

Line Transient Response

(Conditions: $V_{IN} = 2.5V$ to $10V$, $V_{OUT} = 0.8V$, $I_{OUT} = 10mA$,
 $C_{IN} = 0\mu F$, $C_{OUT} = 2.2\mu F$)

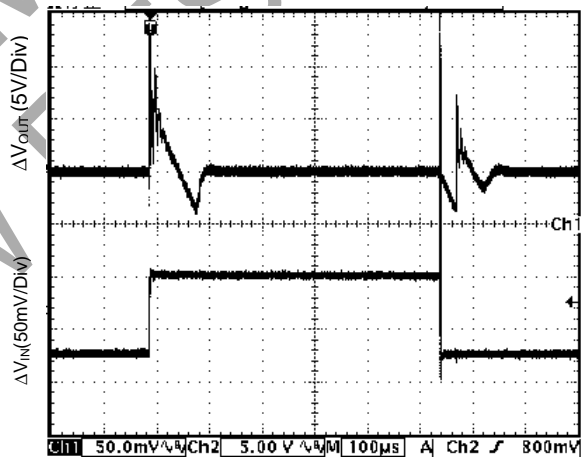

PSRR vs. Frequency

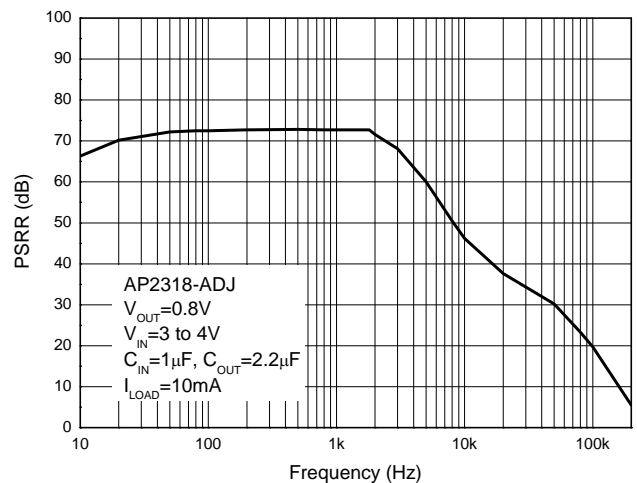

Performance Characteristics (Cont.)

Power Dissipation vs. Ambient Temperature
(Conditions: $V_{OUT} = 1.2V$, $R1 = 3k\Omega$, $R2 = 6.2k\Omega$)

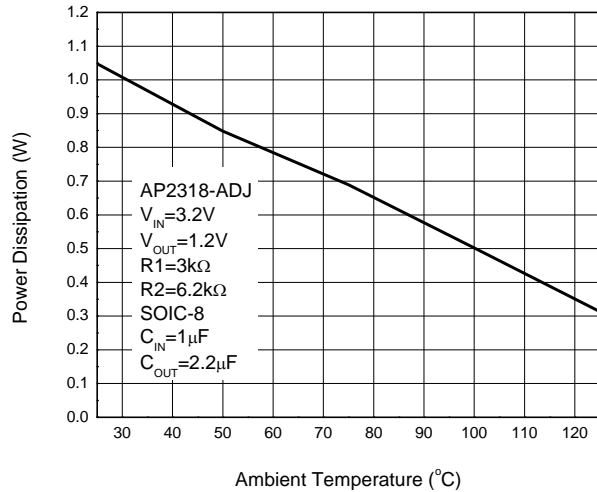

Output Voltage vs. Enable Input Voltage
(Conditions: $V_{OUT} = 1.2V$, $R1 = 3k\Omega$, $R2 = 6.2k\Omega$)

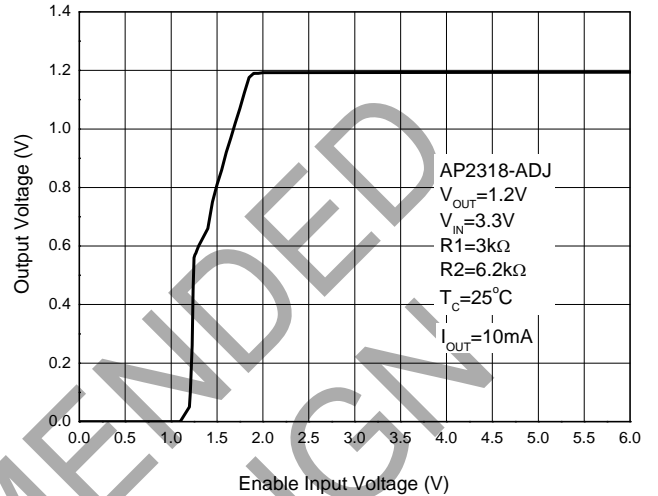

NOT RECOMMENDED FOR NEW DESIGN

Ordering Information

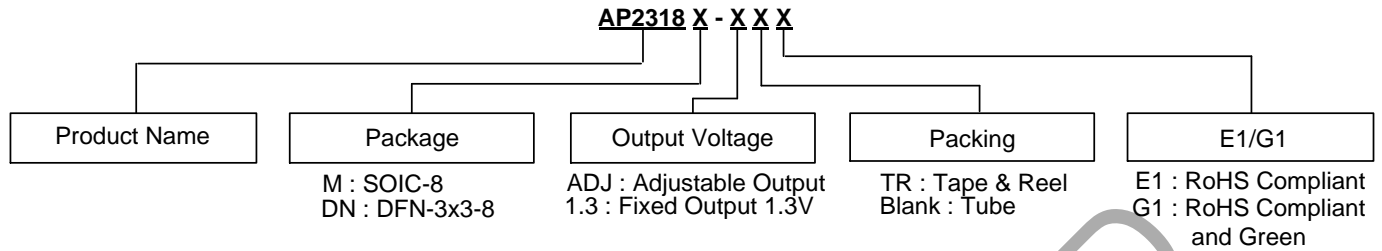

Package	Temperature Range	Part Number		Marking ID		Packing
		RoHS Compliant	RoHS Compliant and Green	RoHS Compliant	RoHS Compliant and Green	
SOIC-8	-40 to +125°C	AP2318M-ADJE1	AP2318M-ADJG1	2318M-ADJE1	2318M-ADJG1	Tube
		AP2318M-ADJTRE1	AP2318M-ADJTRG1	2318M-ADJE1	2318M-ADJG1	Tape & Reel
		AP2318M-1.3E1	AP2318M-1.3G1	2318M-1.3E1	2318M-1.3G1	Tube
		AP2318M-1.3TRE1	AP2318M-1.3TRG1	2318M-1.3E1	2318M-1.3G1	Tape & Reel
DFN-3x3-8	-40 to +125°C	AP2318DN-ADJTRE1	AP2318DN-ADJTRG1	F9E	B9E	Tape & Reel
		AP2318DN-1.3TRE1	AP2318DN-1.3TRG1	F9B	B9B	Tape & Reel

NOT RECOMMENDED FOR NEW DESIGN

Package Outline Dimensions (All dimensions in mm(inch).)

(1) Package Type: SOIC-8

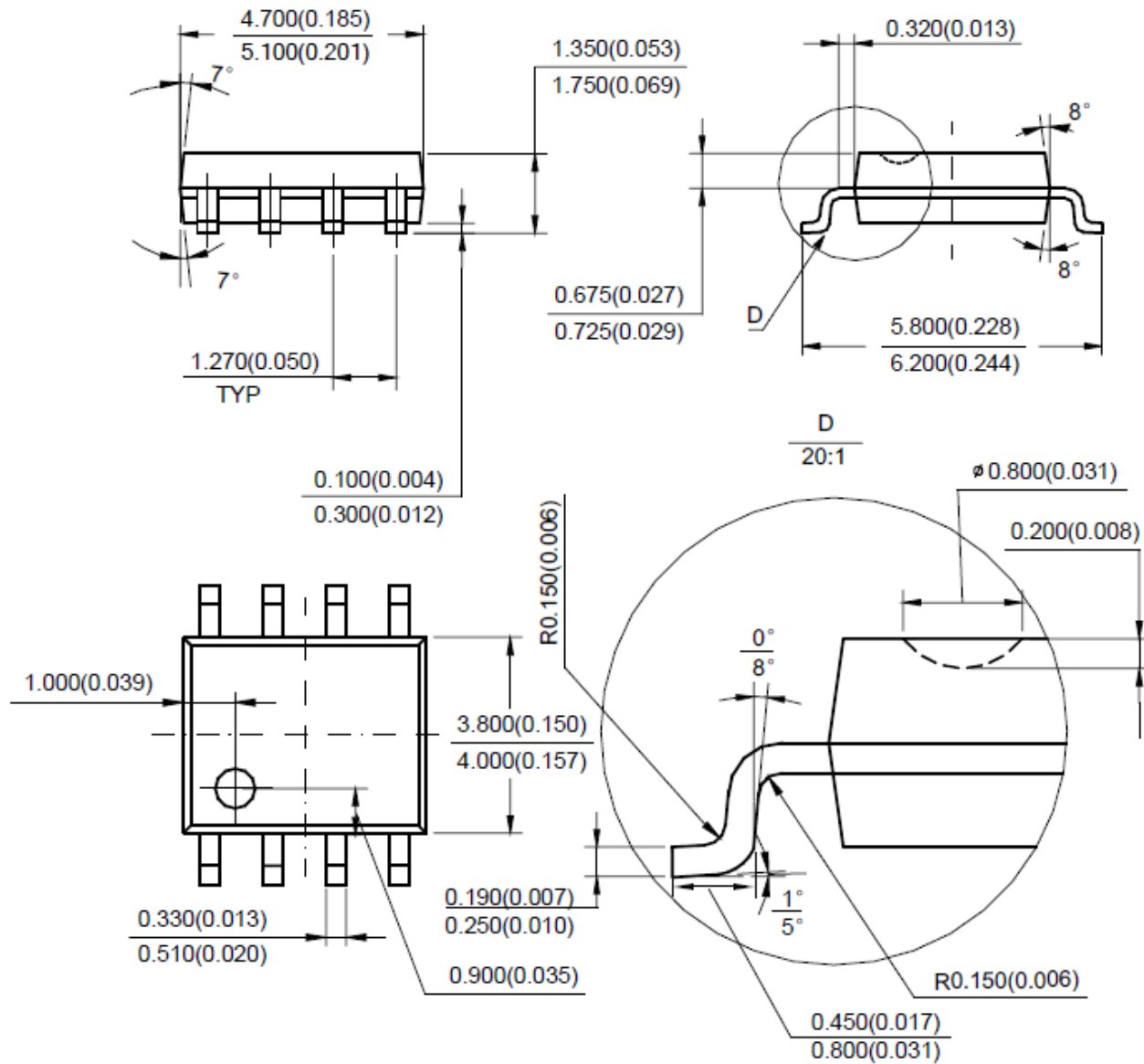

Note: Eject hole, oriented hole and mold mark is optional.

Package Outline Dimensions (Cont. All dimensions in mm(inch).)

(2) Package Type: DFN-3x3-8

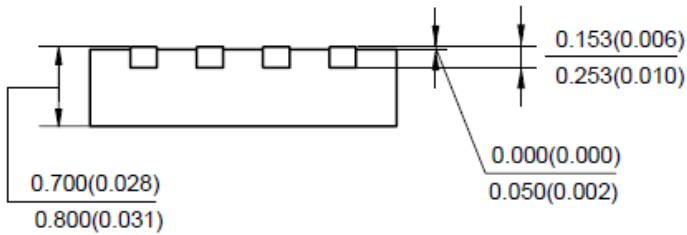
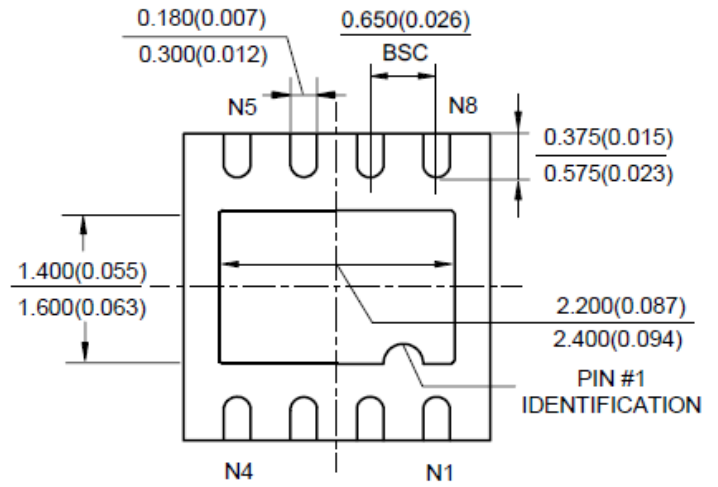
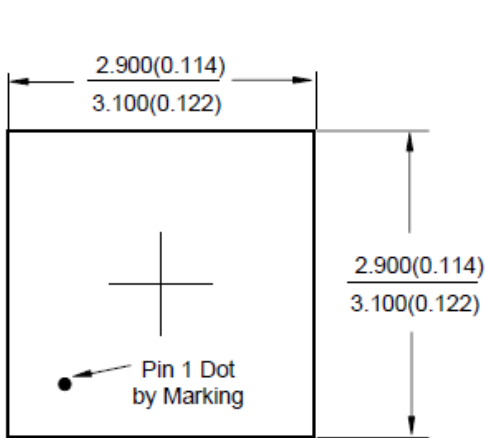

NOT RE
FOR NE

IMPORTANT NOTICE

1. DIODES INCORPORATED AND ITS SUBSIDIARIES (“DIODES”) MAKE NO WARRANTY OF ANY KIND, EXPRESS OR IMPLIED, WITH REGARDS TO ANY INFORMATION CONTAINED IN THIS DOCUMENT, INCLUDING, BUT NOT LIMITED TO, THE IMPLIED WARRANTIES OF MERCHANTABILITY, FITNESS FOR A PARTICULAR PURPOSE OR NON-INFRINGEMENT OF THIRD PARTY INTELLECTUAL PROPERTY RIGHTS (AND THEIR EQUIVALENTS UNDER THE LAWS OF ANY JURISDICTION).
2. The Information contained herein is for informational purpose only and is provided only to illustrate the operation of Diodes products described herein and application examples. Diodes does not assume any liability arising out of the application or use of this document or any product described herein. This document is intended for skilled and technically trained engineering customers and users who design with Diodes products. Diodes products may be used to facilitate safety-related applications; however, in all instances customers and users are responsible for (a) selecting the appropriate Diodes products for their applications, (b) evaluating the suitability of the Diodes products for their intended applications, (c) ensuring their applications, which incorporate Diodes products, comply the applicable legal and regulatory requirements as well as safety and functional-safety related standards, and (d) ensuring they design with appropriate safeguards (including testing, validation, quality control techniques, redundancy, malfunction prevention, and appropriate treatment for aging degradation) to minimize the risks associated with their applications.
3. Diodes assumes no liability for any application-related information, support, assistance or feedback that may be provided by Diodes from time to time. Any customer or user of this document or products described herein will assume all risks and liabilities associated with such use, and will hold Diodes and all companies whose products are represented herein or on Diodes’ websites, harmless against all damages and liabilities.
4. Products described herein may be covered by one or more United States, international or foreign patents and pending patent applications. Product names and markings noted herein may also be covered by one or more United States, international or foreign trademarks and trademark applications. Diodes does not convey any license under any of its intellectual property rights or the rights of any third parties (including third parties whose products and services may be described in this document or on Diodes’ website) under this document.
5. Diodes products are provided subject to Diodes’ Standard Terms and Conditions of Sale (<https://www.diodes.com/about/company/terms-and-conditions/terms-and-conditions-of-sales/>) or other applicable terms. This document does not alter or expand the applicable warranties provided by Diodes. Diodes does not warrant or accept any liability whatsoever in respect of any products purchased through unauthorized sales channel.
6. Diodes products and technology may not be used for or incorporated into any products or systems whose manufacture, use or sale is prohibited under any applicable laws and regulations. Should customers or users use Diodes products in contravention of any applicable laws or regulations, or for any unintended or unauthorized application, customers and users will (a) be solely responsible for any damages, losses or penalties arising in connection therewith or as a result thereof, and (b) indemnify and hold Diodes and its representatives and agents harmless against any and all claims, damages, expenses, and attorney fees arising out of, directly or indirectly, any claim relating to any noncompliance with the applicable laws and regulations, as well as any unintended or unauthorized application.
7. While efforts have been made to ensure the information contained in this document is accurate, complete and current, it may contain technical inaccuracies, omissions and typographical errors. Diodes does not warrant that information contained in this document is error-free and Diodes is under no obligation to update or otherwise correct this information. Notwithstanding the foregoing, Diodes reserves the right to make modifications, enhancements, improvements, corrections or other changes without further notice to this document and any product described herein. This document is written in English but may be translated into multiple languages for reference. Only the English version of this document is the final and determinative format released by Diodes.
8. Any unauthorized copying, modification, distribution, transmission, display or other use of this document (or any portion hereof) is prohibited. Diodes assumes no responsibility for any losses incurred by the customers or users or any third parties arising from any such unauthorized use.

Copyright © 2021 Diodes Incorporated

www.diodes.com