

Description

The AP3431 is a high efficiency step-down DC-DC voltage converter. The chip operation is optimized by peak-current mode architecture with built-in synchronous power MOS switchers. The oscillator and timing capacitors are all built-in providing an internal switching frequency of 1MHz that allows the use of small surface mount inductors and capacitors for portable product implementations.

Integrated Soft Start (SS), Under Voltage Lock Out (UVLO), Thermal Shutdown Detection (TSD) and short circuit protection are designed to provide reliable product applications.

The device is available in adjustable output voltage versions ranging from 0.8V to $0.9 \times V_{IN}$ when input voltage range is from 2.7V to 5.5V, and is able to deliver up to 2.0A.

The AP3431 is available in SOIC-8 package.

Features

- High Efficiency Buck Power Converter
- Output Current: 2A
- Low RDS(ON) Internal Switches : $120m\Omega (V_{IN}=5V)$
- Adjustable Output Voltage from 0.8V to $0.9 \times V_{IN}$
- Wide Operating Voltage Range: 2.7V to 5.5V
- Built-in Power Switches for Synchronous Rectification with High Efficiency
- Feedback Voltage: 800mV
- Switching Frequency: 1.0MHz
- Thermal Shutdown Protection
- Internal Soft Start

Pin Assignments

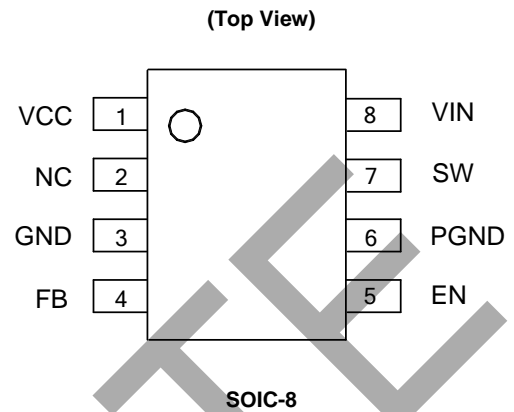

Applications

- LCD TV
- Set Top Box
- Post DC-DC Voltage Regulation
- PDA and Notebook Computer

Typical Applications Circuit (Note 1)

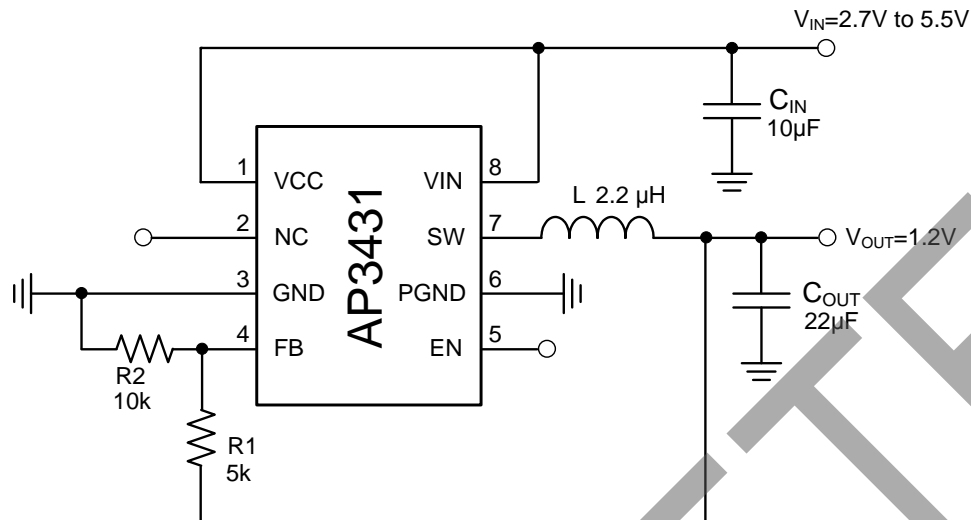

Note 1: $V_{OUT} = V_{FB} \times (1 + \frac{R_1}{R_2})$

V _{out} (V)	R1(kΩ)	R2(kΩ)	L1(µH)
3.3	31.25	10	2.2
2.5	21.5	10	2.2
1.8	12.5	10	2.2
1.2	5	10	2.2
1.0	3	10	2.2

Table 1. Component Guide

Pin Descriptions

Pin Number	Pin Name	Function
1	VCC	Supply input for the analog circuit
2	NC	No connection
3	GND	Ground pin
4	FB	Feedback pin. Receives the feedback voltage from a resistive divider connected across the output
5	EN	Chip enable pin. Active high, internal pull-high with 200kΩ resistor
6	PGND	Power switch ground pin
7	SW	Switch output pin
8	VIN	Power supply input for the MOSFET switch

OBSOLETE – PART DISCONTINUED

Functional Block Diagram

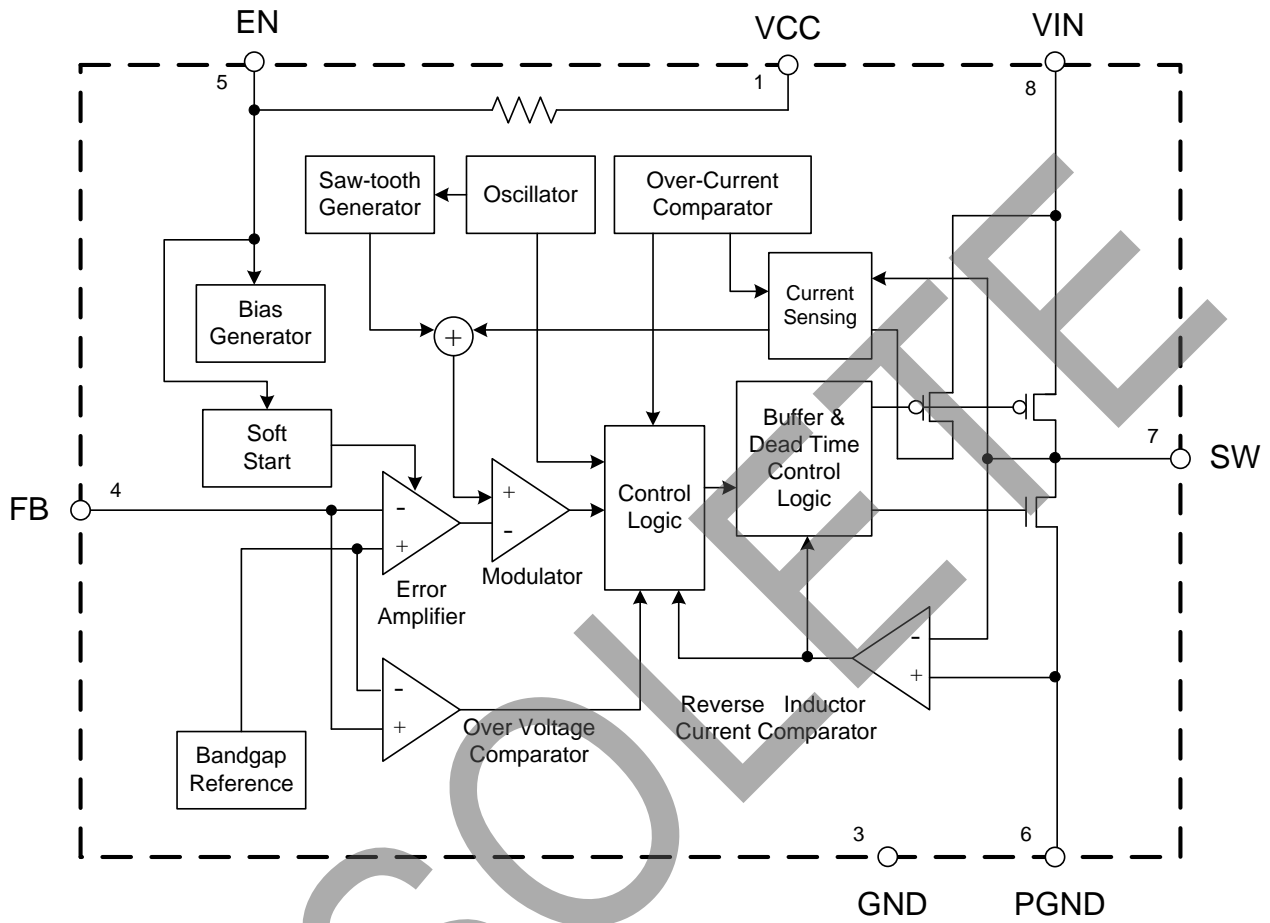

OBSOLETE – PART DISCONTINUED

OBSOLETE

Absolute Maximum Ratings (Note 2)

Symbol	Parameter	Value	Unit
V_{CC}	Supply Input for the Analog Circuit	0 to 6.0	V
V_{IN}	Power Supply Input for the MOSFET Switch	0 to 6.0	V
V_{SW}	SW Pin Switch Voltage	-0.3 to $V_{IN}+0.3$	V
V_{EN}	Enable Voltage	-0.3 to $V_{IN}+0.3$	V
I_{SW}	SW Pin Switch Current	2.9	A
P_D	Power Dissipation (on PCB, $T_A=+25^{\circ}C$)	1.45	W
θ_{JA}	Thermal Resistance (Junction to Ambient, Simulation)	68.63	$^{\circ}C/W$
T_J	Junction Temperature	+160	$^{\circ}C$
T_{OP}	Operating Temperature	-40 to +85	$^{\circ}C$
T_{STG}	Storage temperature	-55 to +150	$^{\circ}C$
V_{HBM}	ESD (Human Body Model)	2000	V
V_{MM}	ESD (Machine Model)	200	V

Note 2: Stresses greater than those listed under “Absolute Maximum Ratings” may cause permanent damage to the device. These are stress ratings only, and functional operation of the device at these or any other conditions beyond those indicated under “Recommended Operating Conditions” is not implied. Exposure to “Absolute Maximum Ratings” for extended periods may affect device reliability.

Recommended Operating Conditions

Symbol	Parameter	Min	Max	Unit
V_{IN}	Supply Input Voltage	2.7	5.5	V
T_J	Junction Temperature Range	-40	+125	$^{\circ}C$
T_A	Ambient Temperature Range	-40	+80	$^{\circ}C$

Electrical Characteristics ($V_{IN}=V_{CC}=V_{EN}=5V$, $V_{OUT}=1.2V$, $V_{FB}=0.8V$, $L=2.2\mu H$, $C_{IN}=10\mu F$, $C_{OUT}=22\mu F$, $T_A=+25^\circ C$, unless otherwise specified.)

Symbol	Parameter	Conditions	Min	Typ	Max	Unit
V_{IN}	Input Voltage Range	–	2.7	–	5.5	V
I_{OFF}	Shutdown Current	$V_{EN}=0V$	–	4	–	μA
I_{ON}	Active Current	$V_{FB} = 0.95V$	–	460	–	μA
V_{FB}	Regulated Feedback Voltage	For Adjustable Output Voltage	0.784	0.8	0.816	V
$\Delta V_{OUT}/V_{OUT}$	Regulated Output Voltage Accuracy	$V_{IN}=2.7V$ to $5.5V$, $I_{OUT}=0$ to $2.0A$	-3	–	3	%
I_{PK}	Peak Inductor Current	–	2.9	–	–	A
f_{OSC}	Oscillator Frequency	$V_{IN} = 2.7V$ to $5.5V$	–	1.0	–	MHz
$R_{ON(P)}$	PMOSFET R_{ON}	$V_{IN} = 5V$	–	120	–	m Ω
$R_{ON(N)}$	NMOSFET R_{ON}	$V_{IN} = 5V$	–	120	–	m Ω
$V_{EN,H}$	EN High-level Input Voltage	–	1.5	–	–	V
$V_{EN,L}$	EN Low-level Input Voltage	–	–	–	0.4	V
I_{EN}	EN Input Current	–	–	2	–	μA
t_{SS}	Soft-start Time	–	–	450	–	μs
D_{MAX}	Maximum Duty Cycle	–	90	–	V	%
–	Under Voltage Lock Out Threshold	Rising	–	2.4	–	V
		Falling	–	2.3	–	V
		Hysteresis	–	0.1	–	V
T_{SD}	Thermal Shutdown	Hysteresis=+30°C	–	+160	–	°C

OBSOLETE – PART DISCONTINUED

OBSOLETE

OBSOLETE – PART DISCONTINUED

Performance Characteristics

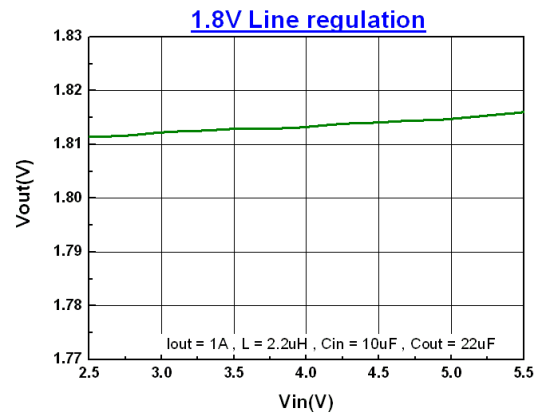
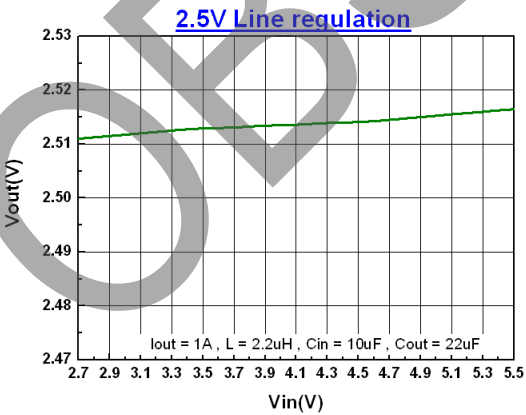
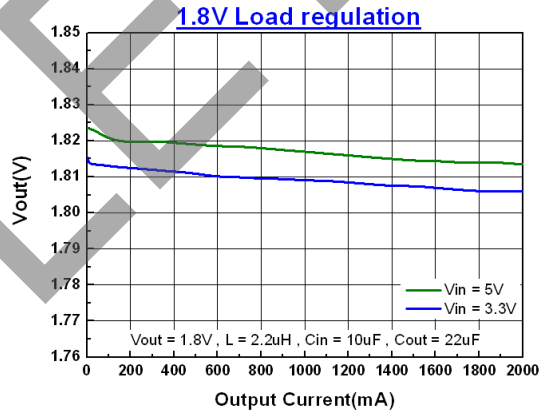
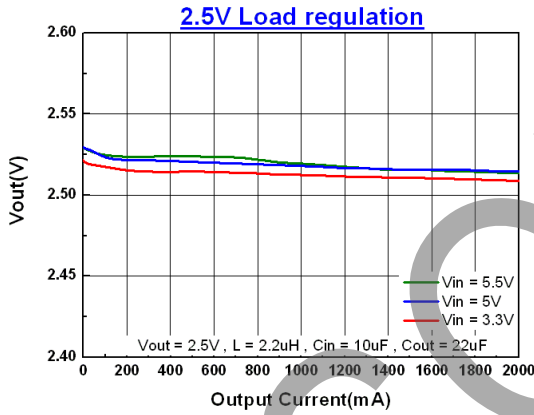
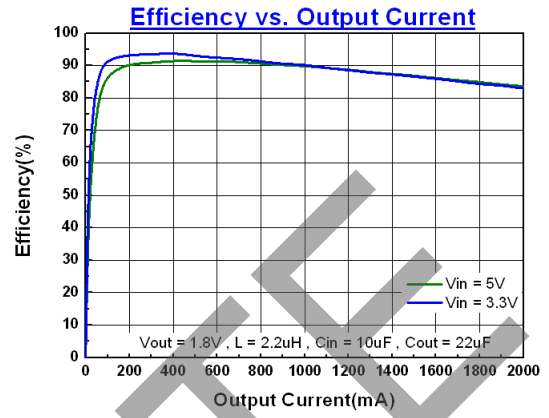
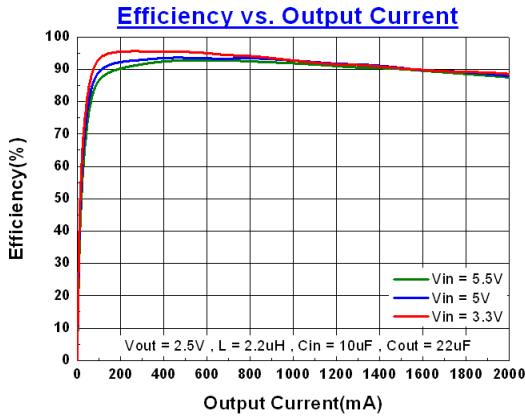

Performance Characteristics (Cont.)

OBSOLETE – PART DISCONTINUED

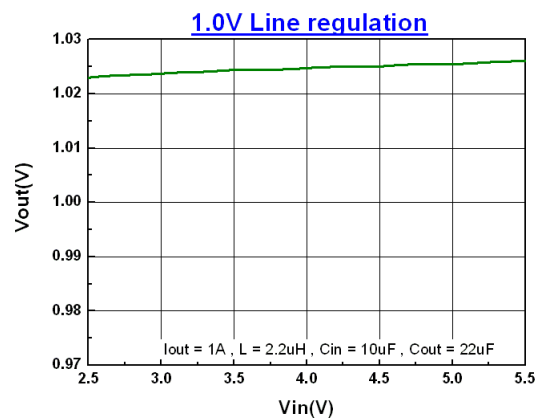
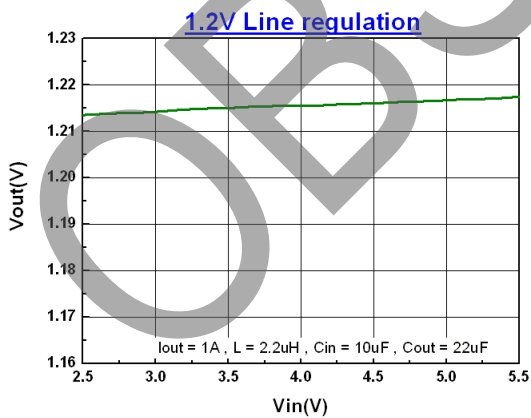
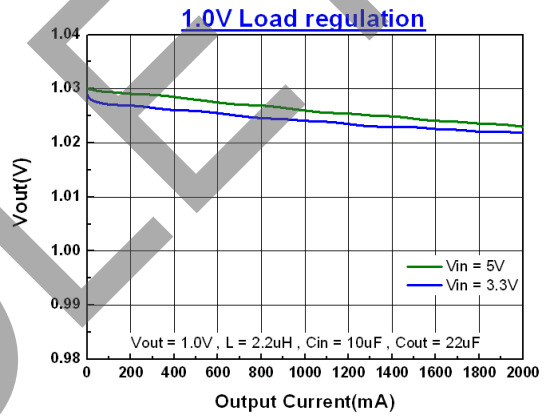
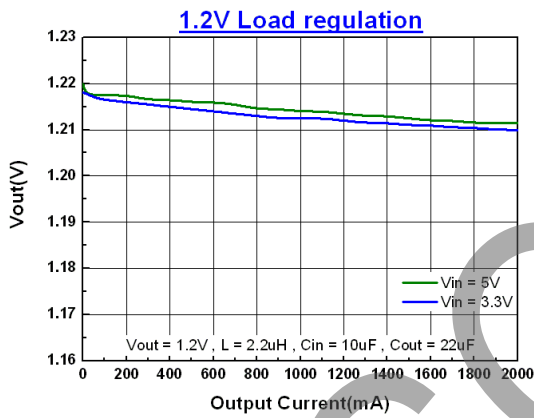
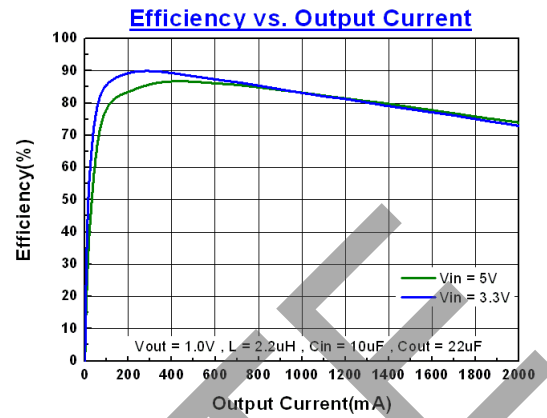
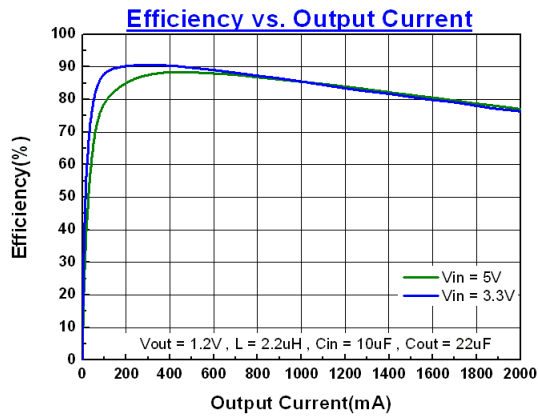

Performance Characteristics (Cont.)

OBSOLETE – PART DISCONTINUED

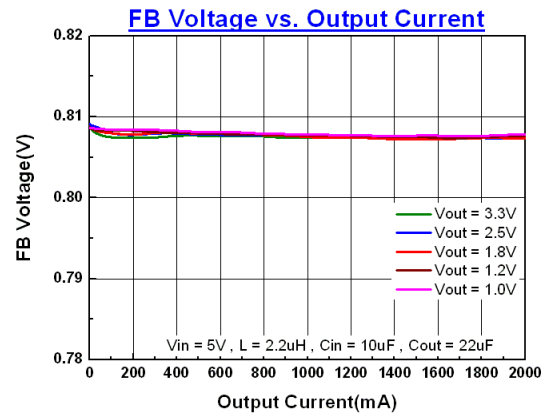
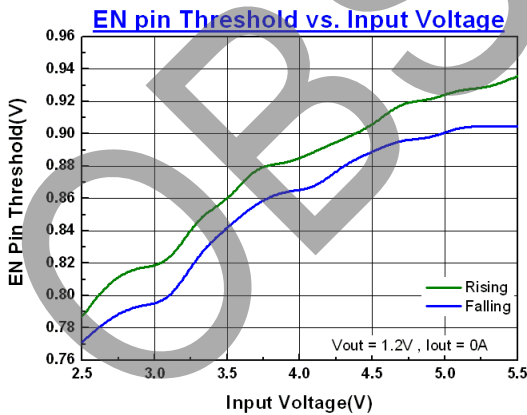
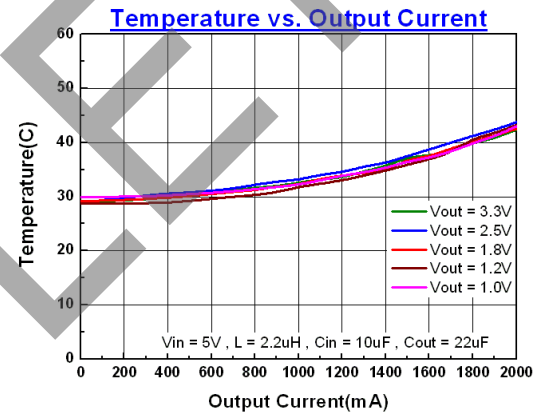
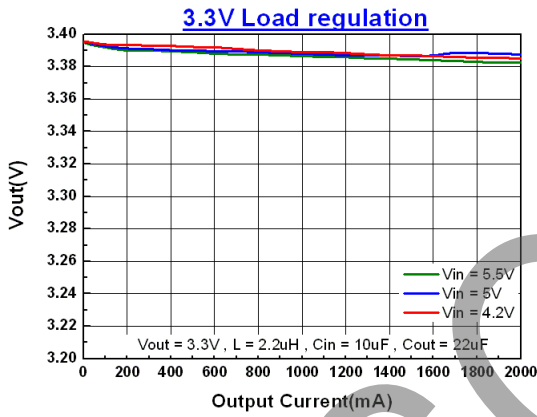
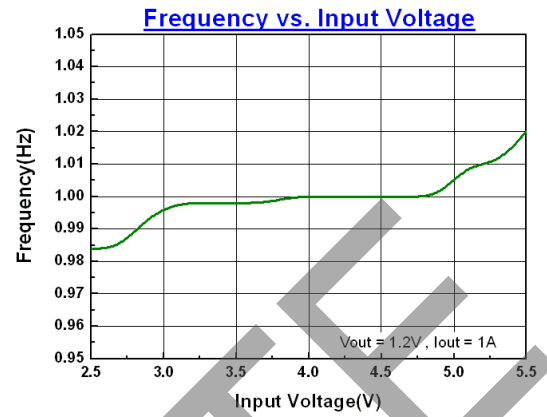
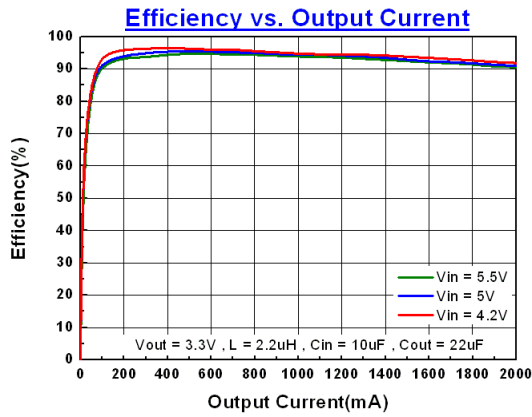

Performance Characteristics (Cont.)

V_{OUT} Ripple
(V_{IN}=5V, V_{OUT}=3.3V, I_{OUT}=500mA)

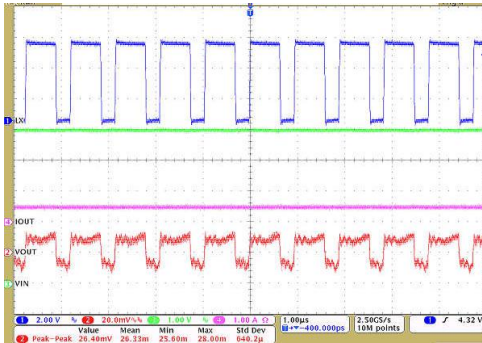

Dynamic Mode
(Load=200mA to 1200mA, V_{IN}=5V, V_{OUT}=3.3V)

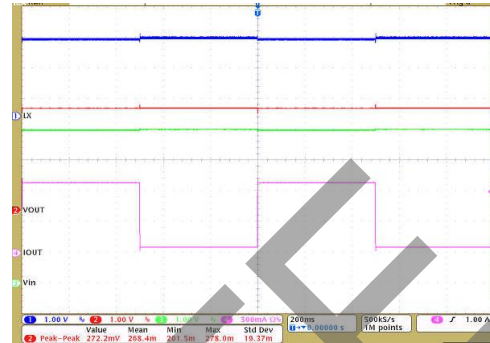

V_{OUT} Ripple
(V_{IN}=5V, V_{OUT}=3.3V, I_{OUT}=1A)

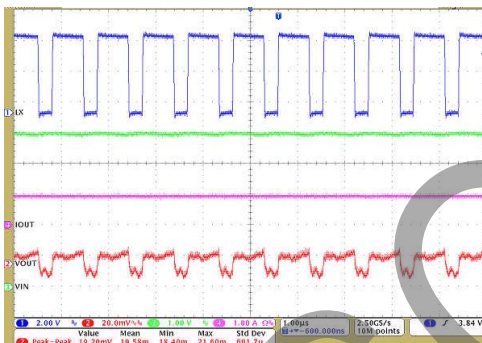

Dynamic Mode (Rising)

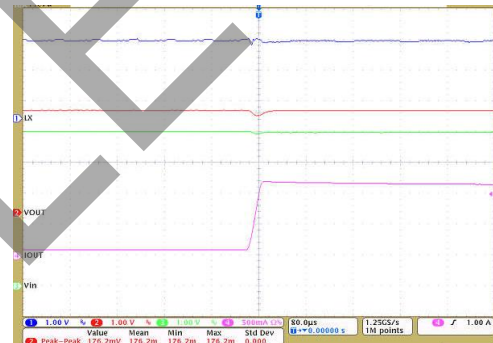

V_{OUT} Ripple
(V_{IN}=5V, V_{OUT}=3.3V, I_{OUT}=2A)

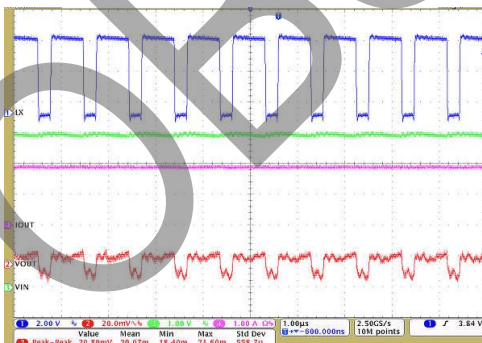

Dynamic Mode (Falling)

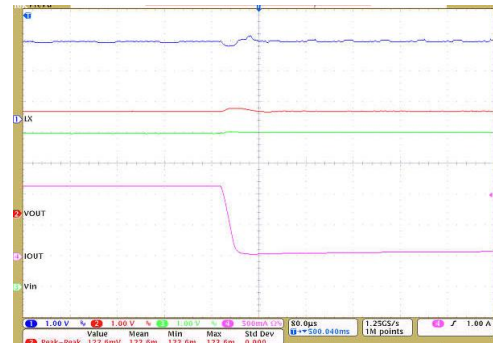

OBSOLETE – PART DISCONTINUED

Performance Characteristics (Cont.)

EN Pin, Low to High
($V_{IN}=5V, V_{OUT}=3.3V, I_{OUT}=100mA$)

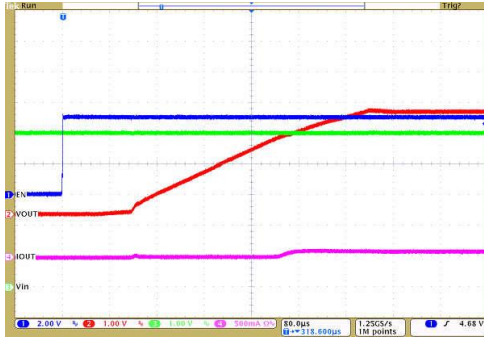

Soft Start
($V_{IN}=5V, V_{OUT}=3.3V, I_{OUT}=0A$)

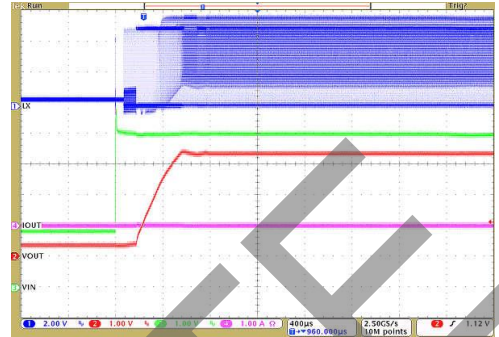

EN Pin, Low to High
($V_{IN}=5V, V_{OUT}=3.3V, I_{OUT}=1A$)

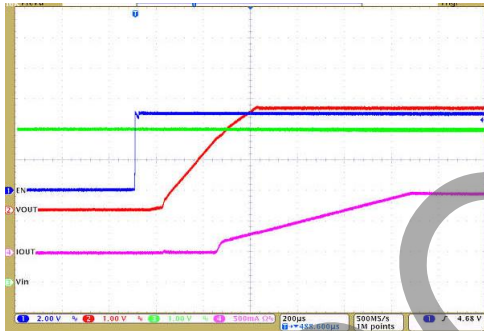

Soft Start
($V_{IN}=5V, V_{OUT}=3.3V, I_{OUT}=1A$)

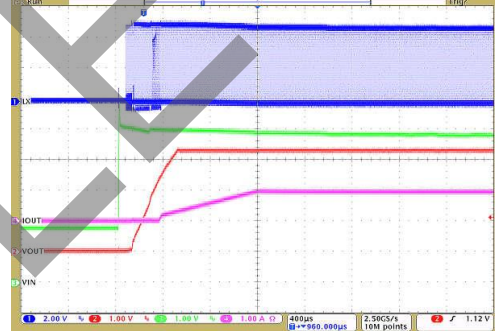

EN Pin, High to Low
($V_{IN}=5V, V_{OUT}=3.3V, I_{OUT}=1A$)



OTP

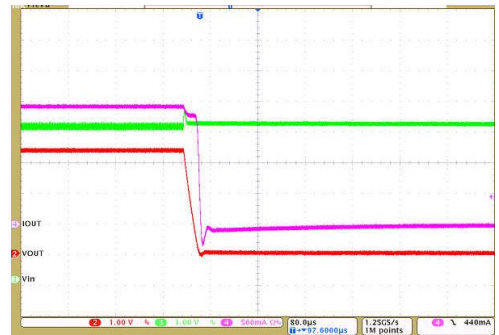

OBSOLETE – PART DISCONTINUED

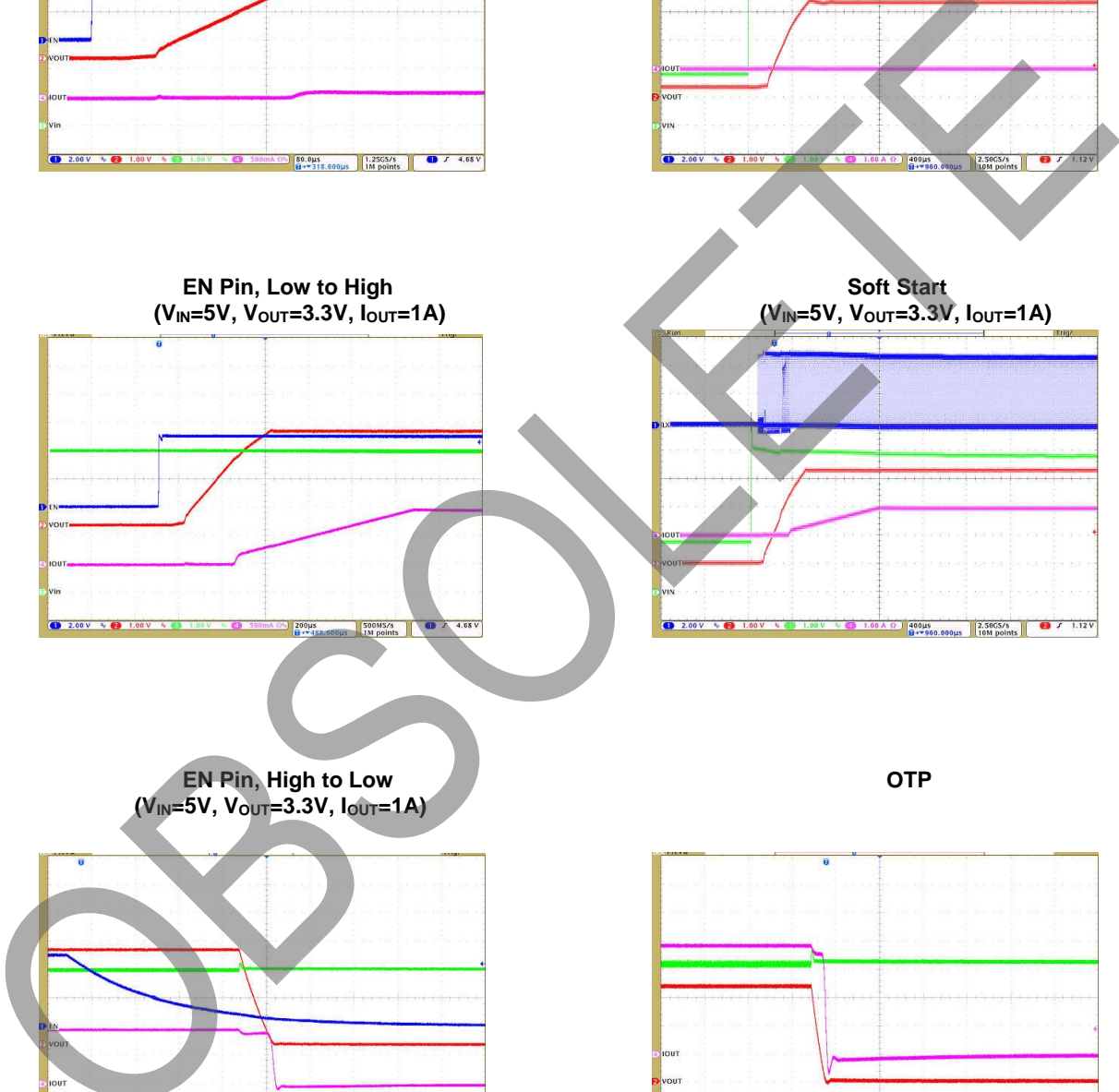

Application Information

The basic AP3431 application circuit is shown in Figure Typical Application Circuit of AP3431, external components selection is determined by the load current and is critical with the selection of inductor and capacitor values.

1. Inductor Selection

For most applications, the value of inductor is chosen based on the required ripple current with the range of 1μH to 6.8μH.

$$\Delta I_L = \frac{1}{f \times L} V_{OUT} \left(1 - \frac{V_{OUT}}{V_{IN}}\right)$$

The largest ripple current occurs at the highest input voltage. Having a small ripple current reduces the ESR loss in the output capacitor and improves the efficiency. The highest efficiency is realized at low operating frequency with small ripple current. However, larger value inductors will be required. A reasonable starting point for ripple current setting is $\Delta I_L = 40\% I_{MAX}$. For a maximum ripple current stays below a specified value, the inductor should be chosen according to the following equation:

$$L = \left[\frac{V_{OUT}}{f \times \Delta I_L (MAX)} \right] \left[1 - \frac{V_{OUT}}{V_{IN} (MAX)} \right]$$

The DC current rating of the inductor should be at least equal to the maximum output current plus half the highest ripple current to prevent inductor core saturation. For better efficiency, a lower DC-resistance inductor should be selected.

2. Capacitor Selection

The input capacitance, C_{IN}, is needed to filter the trapezoidal current at the source of the top MOSFET. To prevent large ripple voltage, a low ESR input capacitor sized for the maximum RMS current must be used. The maximum RMS capacitor current is given by:

$$I_{RMS} = I_{OMAX} \times \frac{[V_{OUT} (V_{IN} - V_{OUT})]^{\frac{1}{2}}}{V_{IN}}$$

It indicates a maximum value at $V_{IN} = 2V_{OUT}$, where $I_{RMS} = I_{OUT}/2$. This simple worst-case condition is commonly used for design because even significant deviations do not much relieve. The selection of C_{OUT} is determined by the Effective Series Resistance (ESR) that is required to minimize output voltage ripple and load step transients, as well as the amount of bulk capacitor that is necessary to ensure that the control loop is stable. Loop stability can be also checked by viewing the load step transient response as described in the following section. The output ripple, ΔV_{OUT} , is determined by:

$$\Delta V_{OUT} \leq \Delta I_L \left[ESR + \frac{1}{8 \times f \times C_{OUT}} \right]$$

The output ripple is the highest at the maximum input voltage since ΔI_L increases with input voltage.

3. Load Transient

A switching regulator typically takes several cycles to respond to the load current step. When a load step occurs, V_{OUT} immediately shifts by an amount equal to $\Delta I_{LOAD} \times ESR$, where ESR is the effective series resistance of output capacitor. ΔI_{LOAD} also begins to charge or discharge C_{OUT} generating a feedback error signal used by the regulator to return V_{OUT} to its steady-state value. During the recovery time, V_{OUT} can be monitored for overshoot or ringing that would indicate a stability problem.

4. Output Voltage Setting

The output voltage of AP3431 can be adjusted by a resistive divider according to the following formula:

$$V_{OUT} = V_{REF} \times \left(1 + \frac{R_1}{R_2}\right) = 0.8V \times \left(1 + \frac{R_1}{R_2}\right)$$

Application Information (Cont.)

The resistive divider senses the fraction of the output voltage as shown in Figure of Setting the Output Voltage .

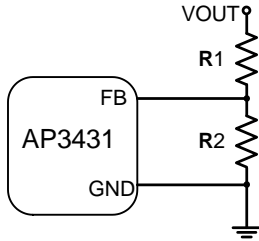

Setting the Output Voltage

5. Short Circuit Protection

When the AP3431 output node is shorted to GND, as VFB drop under 0.4V, the chip will enter soft-start mode to protect itself, when short circuit is removed, and VFB rise over 0.4V, the AP3431 recover back to normal operation again. If the AP3431 reach OCP threshold while short circuit, the AP3431 will enter soft-start cycle until the current under OCP threshold.

6. Efficiency Considerations

The efficiency of switching regulator is equal to the output power divided by the input power times 100%. It is usually useful to analyze the individual losses to determine what is limiting efficiency and which change could produce the largest improvement. Efficiency can be expressed as:

$$\text{Efficiency} = 100\% - L_1 - L_2 - \dots$$

Where L1, L2, etc. are the individual losses as a percentage of input power.

Although all dissipative elements in the regulator produce losses, two major sources usually account for most of the power losses: V_{IN} quiescent current and I^2R losses. The V_{IN} quiescent current loss dominates the efficiency loss at very light load currents and the I^2R loss dominates the efficiency loss at medium to heavy load currents.

6.1 The V_{IN} quiescent current loss comprises two parts: the DC bias current as given in the electrical characteristics and the internal MOSFET switch gate charge currents. The gate charge current results from switching the gate capacitance of the internal power MOSFET switches. Each cycle the gate is switched from high to low, then to high again, and the packet of charge, dQ moves from V_{IN} to ground. The resulting dQ/dt is the current out of V_{IN} that is typically larger than the internal DC bias current. In continuous mode,

$$I_{GATE} = f \times (Q_P + Q_N)$$

Where Q_P and Q_N are the gate charge of power PMOSFET and NMOSFET switches. Both the DC bias current and gate charge losses are proportional to the V_{IN} and this effect will be more serious at higher input voltages.

6.2 I^2R losses are calculated from internal switch resistance, R_{SW} and external inductor resistance R_L . In continuous mode, the average output current flowing through the inductor is chopped between power PMOSFET switch and NMOSFET switch. Then, the series resistance looking into the SW pin is a function of both PMOSFET and NMOSFET $R_{DS(ON)}$ resistance and the duty cycle (D) are as follows:

$R_{DS(ON)}$ resistance and the duty cycle (D):

$$R_{SW} = R_{DS(ON)P} \times D + R_{DS(ON)N} \times (1 - D)$$

Therefore, to obtain the I^2R losses, simply add R_{SW} to R_L and multiply the result by the square of the average output current.

OBSOLETE – PART DISCONTINUED

Application Information (Cont.)

Other losses including C_{IN} and C_{OUT} ESR dissipative losses and inductor core losses generally account for less than 2 % of total additional loss.

7. Thermal Characteristics

In most applications, the part does not dissipate much heat due to its high efficiency. However, in some conditions when the part is operating in high ambient temperature with high $R_{DS(ON)}$ resistance and high duty cycles, such as in LDO mode, the heat dissipated may exceed the maximum junction temperature. To avoid the part from exceeding maximum junction temperature, the user should do some thermal analysis. The maximum power dissipation depends on the layout of PCB, the thermal resistance of IC package, the rate of surrounding airflow and the temperature difference between junction and ambient.

8. PCB Layout Considerations

When laying out the printed circuit board, the following checklist should be used to optimize the performance of AP3431.

- 1) The power traces, including the GND trace, the SW trace and the VIN trace should be kept direct, short and wide.
- 2) Put the input capacitor as close as possible to the V_{IN} and GND pins.
- 3) The FB pin should be connected directly to the feedback resistor divider.
- 4) Keep the switching node, SW, away from the sensitive FB pin and the node should be kept small area.

Ordering Information

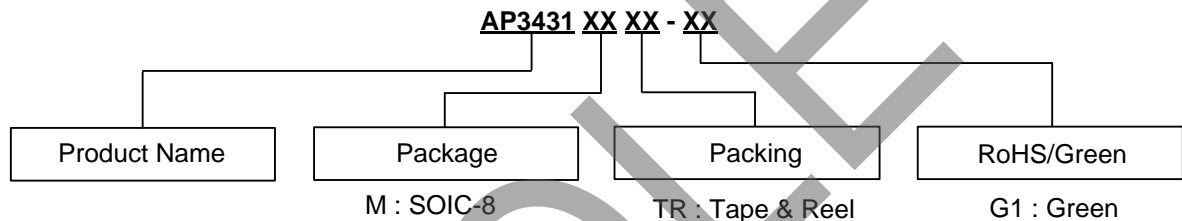

Package	Temperature Range	Part Number	Marking ID	Packing
SOIC-8	-40 to +80°C	AP3431M-G1	3431M-G1	Tube
		AP3431MTR-G1	3431M-G1	Tape & Reel

OBSOLETE – PART DISCONTINUED

Package Outline Dimensions (All dimensions in mm(inch).)

(1) Package Type: SOIC-8

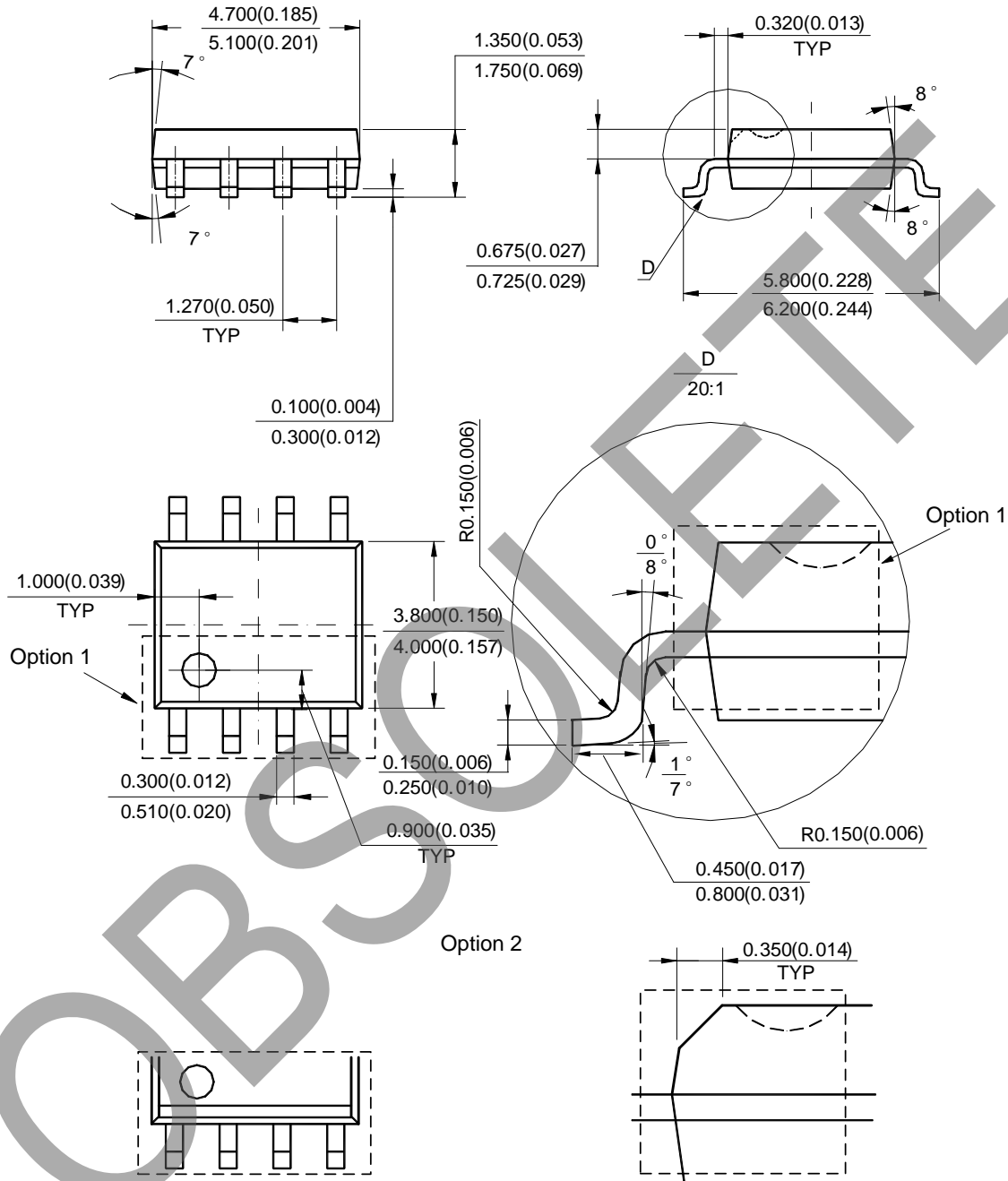

Note: Eject hole, oriented hole and mold mark is optional.

OBSOLETE – PART DISCONTINUED

Suggested Pad Layout

(1) Package Type: SOIC-8

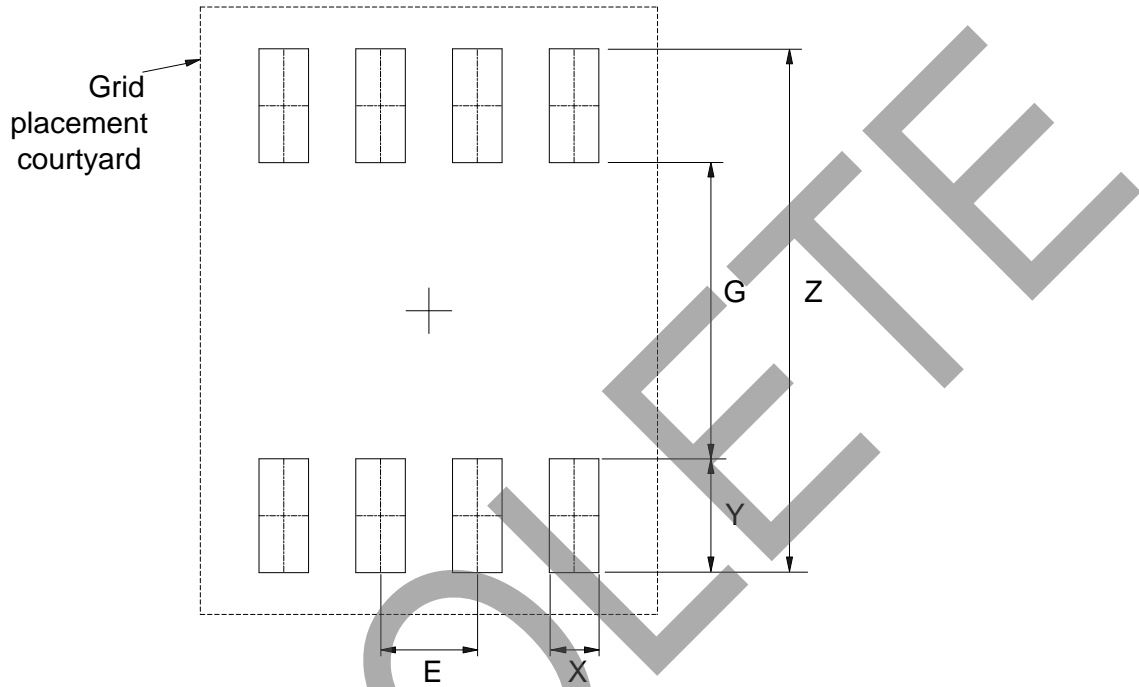

Dimensions	Z (mm)/(inch)	G (mm)/(inch)	X (mm)/(inch)	Y (mm)/(inch)	E (mm)/(inch)
Value	6.900/0.272	3.900/0.154	0.650/0.026	1.500/0.059	1.270/0.050

OBSOLETE – PART DISCONTINUED

OBSOLETE

IMPORTANT NOTICE

DIODES INCORPORATED MAKES NO WARRANTY OF ANY KIND, EXPRESS OR IMPLIED, WITH REGARDS TO THIS DOCUMENT, INCLUDING, BUT NOT LIMITED TO, THE IMPLIED WARRANTIES OF MERCHANTABILITY AND FITNESS FOR A PARTICULAR PURPOSE (AND THEIR EQUIVALENTS UNDER THE LAWS OF ANY JURISDICTION).

Diodes Incorporated and its subsidiaries reserve the right to make modifications, enhancements, improvements, corrections or other changes without further notice to this document and any product described herein. Diodes Incorporated does not assume any liability arising out of the application or use of this document or any product described herein; neither does Diodes Incorporated convey any license under its patent or trademark rights, nor the rights of others. Any Customer or user of this document or products described herein in such applications shall assume all risks of such use and will agree to hold Diodes Incorporated and all the companies whose products are represented on Diodes Incorporated website, harmless against all damages.

Diodes Incorporated does not warrant or accept any liability whatsoever in respect of any products purchased through unauthorized sales channel. Should Customers purchase or use Diodes Incorporated products for any unintended or unauthorized application, Customers shall indemnify and hold Diodes Incorporated and its representatives harmless against all claims, damages, expenses, and attorney fees arising out of, directly or indirectly, any claim of personal injury or death associated with such unintended or unauthorized application.

Products described herein may be covered by one or more United States, international or foreign patents pending. Product names and markings noted herein may also be covered by one or more United States, international or foreign trademarks.

This document is written in English but may be translated into multiple languages for reference. Only the English version of this document is the final and determinative format released by Diodes Incorporated.

LIFE SUPPORT

Diodes Incorporated products are specifically not authorized for use as critical components in life support devices or systems without the express written approval of the Chief Executive Officer of Diodes Incorporated. As used herein:

A. Life support devices or systems are devices or systems which:

1. are intended to implant into the body, or
2. support or sustain life and whose failure to perform when properly used in accordance with instructions for use provided in the labeling can be reasonably expected to result in significant injury to the user.

B. A critical component is any component in a life support device or system whose failure to perform can be reasonably expected to cause the failure of the life support device or to affect its safety or effectiveness.

Customers represent that they have all necessary expertise in the safety and regulatory ramifications of their life support devices or systems, and acknowledge and agree that they are solely responsible for all legal, regulatory and safety-related requirements concerning their products and any use of Diodes Incorporated products in such safety-critical, life support devices or systems, notwithstanding any devices- or systems-related information or support that may be provided by Diodes Incorporated. Further, Customers must fully indemnify Diodes Incorporated and its representatives against any damages arising out of the use of Diodes Incorporated products in such safety-critical, life support devices or systems.

Copyright © 2018, Diodes Incorporated

www.diodes.com