

Description

The AP3928 is a universal AC voltage step-down power switcher, specially designed for home appliances and IoT applications with non-isolated buck solution.

The device integrates a 700V high-performance power MOSFET. Coordinating with a single-winding inductor, it uses fewer external components and provides a low bill of materials (BOM) cost solution.

The AP3928 can achieve high output current, excellent constant voltage regulation, and high conversion efficiency. The peak current and switching frequency continuously reduces as the load decreases, so the device can achieve excellent efficiency performance at light load and improve overall system efficiency.

The AP3928 has multiple protection features to enhance the system safety and reliability. The device has overtemperature protection, undervoltage lock function, output short protection, overload protection, and open-loop protection.

The AP3928 is available in the SO-8 (Standard) package.

Features

- Universal 85V_{AC} to 300V_{AC} Input Range
- Internal MOSFET of 700V
- Maximal Peak Current: 1.1A Typical.
- Maximum 600mA Rated Output Current
- Up to 10W Output Power
- No Load Power Consumption: < 30mW with External Bias
- Frequency Modulation to Suppress EMI
- Various Protections: OTP (Overtemperature Protection), OLP (Overload Protection), SCP (Short-Circuit Protection)
- Fewer Components
- Low Audible Noise Solution
- SO-8 (Standard) Package
- **Totally Lead-Free & Fully RoHS Compliant (Notes 1 & 2)**
- **Halogen and Antimony Free. "Green" Device (Note 3)**
- **For automotive applications requiring specific change control (i.e. parts qualified to AEC-Q100/101/104/200, PPAP capable, and manufactured in IATF 16949 certified facilities), please [contact us](https://www.diodes.com/contact-us) or your local Diodes representative. <https://www.diodes.com/quality/product-definitions/>**

Pin Assignments

(Top View)

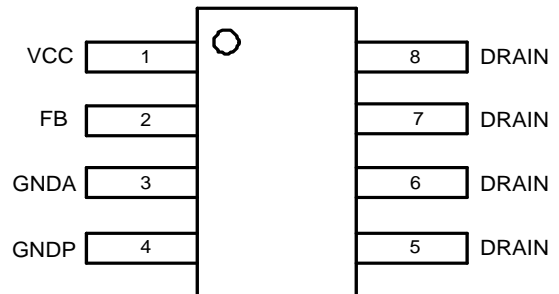

SO-8 (Standard)

Applications

- Home appliances
- IoT applications
- Industrial controls
- Standby power and auxiliary power

Notes:

1. No purposely added lead. Fully EU Directive 2002/95/EC (RoHS), 2011/65/EU (RoHS 2) & 2015/863/EU (RoHS 3) compliant.
2. See <https://www.diodes.com/quality/lead-free/> for more information about Diodes Incorporated's definitions of Halogen- and Antimony-free, "Green" and Lead-free.
3. Halogen- and Antimony-free "Green" products are defined as those which contain <900ppm bromine, <900ppm chlorine (<1500ppm total Br + Cl) and <1000ppm antimony compounds.

Typical Applications Circuit

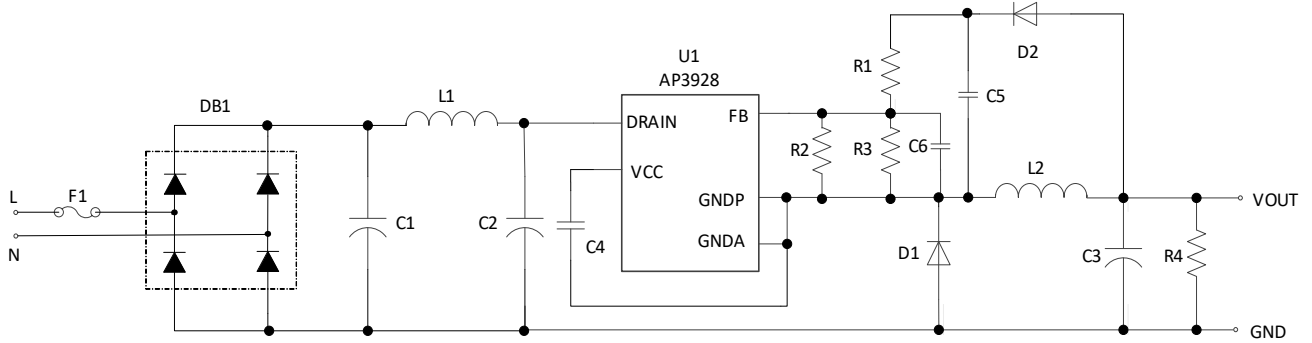

Pin Descriptions

Pin Number	Pin Name	Function
1	VCC	Connection Point of External Bypass Capacitor for Internally Generated Control Circuit Power Supply.
2	FB	Regulator Feedback.
3	GNDA	Ground Reference for VCC and FB Pins. Short to GNDP Pin in the Application.
4	GNDP	IC Power Ground.
5, 6, 7, 8	DRAIN	Internal Power MOSFET Drain. High-Voltage Current Source Input.

Functional Block Diagram

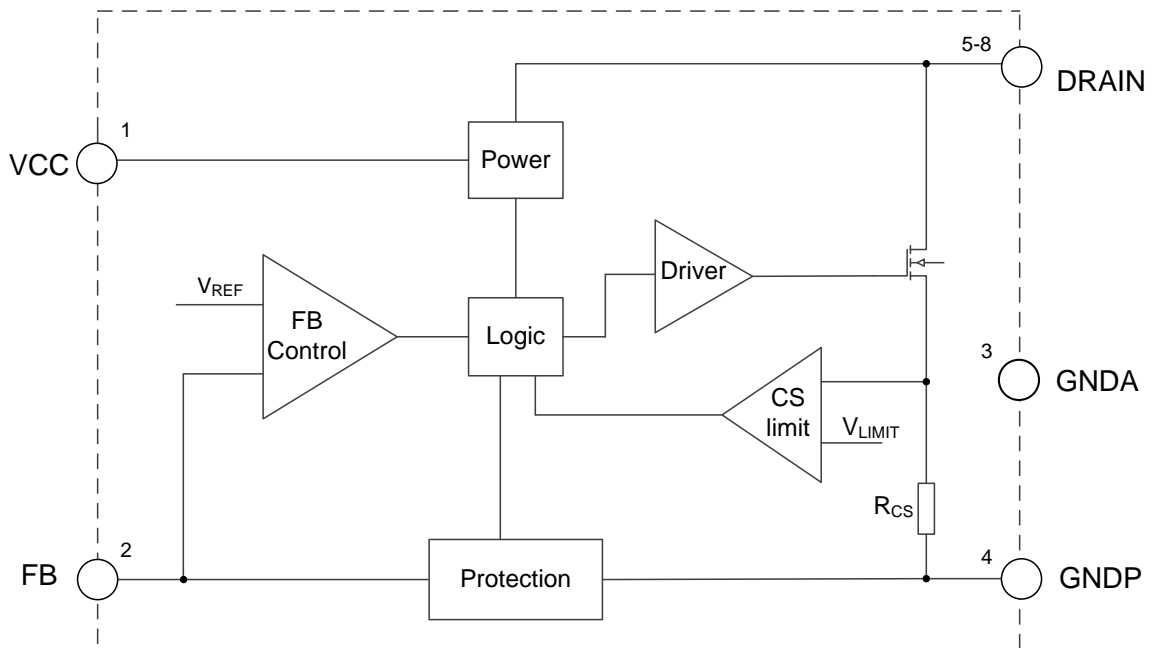

Absolute Maximum Ratings (Note 4)

Symbol	Parameter	Rating	Unit
V _{DSS}	Drain Pin Voltage	-0.3 to 700	V
VCC	Internally Generated Control Circuit Power Supply	-0.3 to 20	V
V _{FB} , G _{NDA} , G _{NDP}	FB, GNDA and GNDP Pin Voltage	-0.3 to 6.5	V
P _D	Continuous Power Dissipation (T _A = +25°C)	2	W
T _J	Operating Junction Temperature	+150	°C
T _{STG}	Storage Temperature	-65 to +150	°C
T _{LEAD}	Lead Temperature (Soldering, 10s)	+300	°C
θ _{JA}	Thermal Resistance (Junction to Ambient) (Note 5)	76	°C/W
θ _{JC}	Thermal Resistance (Junction to Case)	23	°C/W
—	ESD (Human Body Model)	4000	V
—	ESD (Charge Device Model)	1000	V

- Notes:
- Stresses greater than those listed under *Absolute Maximum Ratings* can cause permanent damage to the device. These are stress ratings only, and functional operation of the device at these or any other conditions beyond those indicated under *Recommended Operating Conditions* is not implied. Exposure to *Absolute Maximum Ratings* for extended periods can affect device reliability.
 - Test condition: device mounted on FR-4 substrate PC board, 2oz copper, with 1inch² cooling area.

Recommended Operating Conditions

Symbol	Parameter	Min	Max	Unit
VCC	Supply Voltage	7.9	19	V
V _{DSS}	Drain-Source Voltage (Note 6)	—	560	V
T _A	Ambient Temperature	-40	+125	°C

- Note:
- The drain-source voltage is 80% of V_{DSS} in the aging condition.

Electrical Characteristics (VCC = 8.8V, -40°C < TA < +125°C, unless otherwise specified.)

Symbol	Parameter	Condition	Min	Typ	Max	Unit
HV Startup Current Source						
I _{HV}	HV Supply Current	VCC = 7V VDRAIN = 100V	1	3.5	10	mA
I _{LEAK}	Leakage Current of Drain	VCC = 9.5V VDRAIN = 400V TA = +25°C	—	10	12	μA
VCC Voltage Management						
VCC_HVOFF	VCC Increasing Level at which HV Supply is OFF	—	8.4	9	9.6	V
VCC_HVON	VCC Decreasing Level at which HV Supply is ON	—	7.9	8.5	9.1	V
VCC_HYS	VCC Hysteresis (VCC_HVOFF - VCC_HVON)	—	200	—	—	mV
VCC_UVLO	VCC Minimum Operating Voltage	TA = +25°C	7.3	7.9	8.5	V
VCC_RESTART	VCC Restart Voltage	—	3	4.5	5.5	V
I _{CC1}	VCC Operating Current with MOSFET Switching	VCC = 9.5V, f = 58kHz TA = +25°C	450	850	1150	μA
I _{CC2}	VCC Quiescent Current with No Switching	TA = +25°C	80	136	300	μA
I _{CC_LATCH}	VCC Latch Off-Current	VCC = 9.5V, TA = +25°C	—	26	50	μA
Internal MOSFET						
V _{DSS}	Breakdown Voltage	TA = +25°C (Note 7)	700	—	—	V
R _{DS(ON)}	ON Resistance	TA = +25°C	—	5.2	6.5	Ω
Internal Current Sense						
I _{PK_MAX}	Maximum Peak Current	TA = +25°C	980	1100	1220	mA
t _{LEB1}	Leading-Edge Blanking	TA = +25°C	—	350	470	ns
I _{SCP}	Current Set Point for Short-Circuit Protection	TA = +25°C (Note 8)	1500	1925	2200	mA
t _{LEB2}	Leading-Edge Blanking for Short-Circuit Protection	TA = +25°C (Note 8)	—	200	—	ns
Feedback Input (FB Pin)						
t _{MINOFF}	Minimum OFF-Time	TA = +25°C	11	13	15	μs
t _{MAXON}	Maximal ON-Time	TA = +25°C	29	35	41	μs
V _{FB}	Feedback Voltage for MOSFET Switch-On Threshold	—	2.4	2.5	2.6	V
OLP_Counting	The Counting Cycle for OLP	—	—	8192	—	cycle
V _{OLD}	Open-Loop Detection Voltage	TA = +25°C	0.2	0.3	0.4	V
Overtemperature Protection						
T _{OTP}	Thermal Shutdown Threshold	(Note 8)	+135	+150	+165	°C
	Thermal Shutdown Hysteresis	(Note 8)	—	+30	—	°C

Notes: 7. The drain-source voltage is 80% of V_{DSS} in the aging condition.
8. Guaranteed by design.

Performance Characteristics

FB Voltage vs. Ambient Temperature

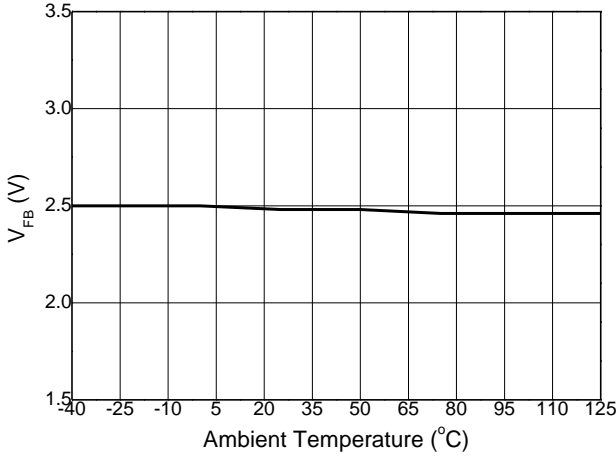

V_{BP_HVON} Voltage vs. Ambient Temperature

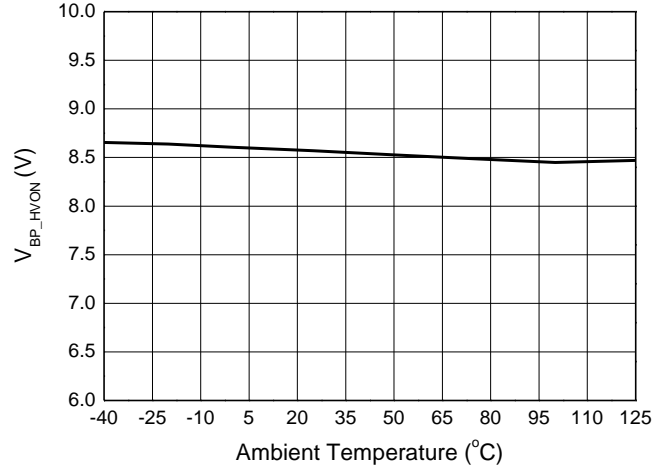

V_{BP_HVOFF} Voltage vs. Ambient Temperature

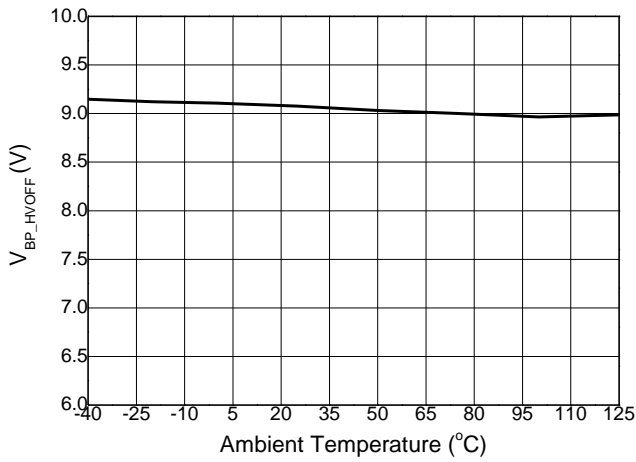

R_{DS(ON)} vs. Ambient Temperature

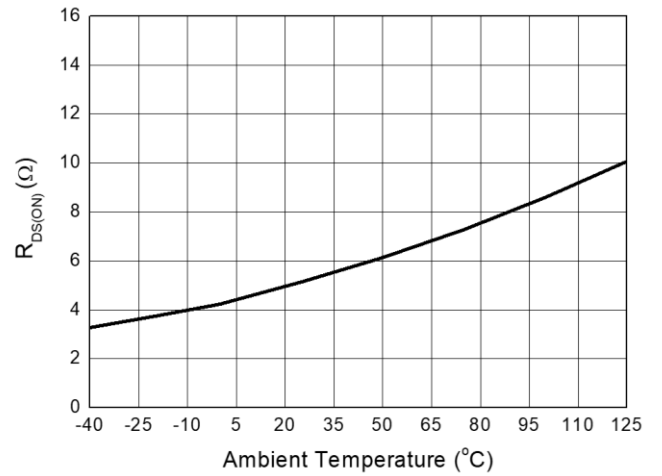

Performance Characteristics (continued)

The value of R5 can be determined by the following equation:

$$R5 = \frac{V_O - V_{CC_HVON}}{I_{CC2}}$$

Constant Voltage Operation

The AP3928 can be used in a buck circuit as shown in the *Typical Applications Circuit*. In the beginning of each cycle, the internal integrated MOSFET turns ON when the FB voltages fall below the reference voltage V_{FB} (2.5V). The FB voltage is derived from the sampling capacitor voltage, which can reflect output voltage.

The ON period time is determined by the inductor current variable value ΔI_L, (ΔI_L is the gap of the peak-current limitation value I_{PK} and the initial inductor current value I_{INI}), the inductance value, and the input voltage. The ON time calculation is as follows:

$$t_{ON} = L \cdot \frac{\Delta I_L}{V_{IN_DC}} = L \cdot \frac{I_{PK} - I_{INI}}{V_{IN_DC}}$$

Where I_{INI} is zero in DCM status.

When the inductor current reaches peak-current limitation, the internal MOSFET will turn off. The inductor current charges the sampling capacitor (C5) and the output capacitor (C3) via the freewheeling diodes D2 and D1 respectively. In this stage, the sampling capacitor voltage reflects the output voltage.

The output voltage can be regulated by sampling the FB voltage. In the MOSFET OFF time, the inductor current decreases linearly from peak current. When the inductor current falls below the output current, the FB voltage begins to decrease with the sampling capacitor voltage decreasing. Once the FB voltage is detected below the reference voltage of primary MOSFET turn-on threshold, a new switching cycle starts.

The regulated output voltage can be described as the following equation:

$$V_O = V_{FB} \times \left(\frac{R_{UP} + R_{DOWN}}{R_{DOWN}} \right)$$

Where, R_{UP} = R1 and R_{DOWN} = $\frac{R2 \cdot R3}{R2 + R3}$.

Figures 3(a) and 3(b) show the operation diagram under DCM and CCM.

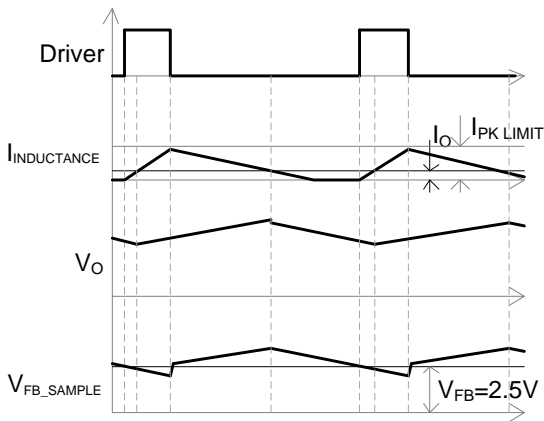

Figure 3(a). DCM

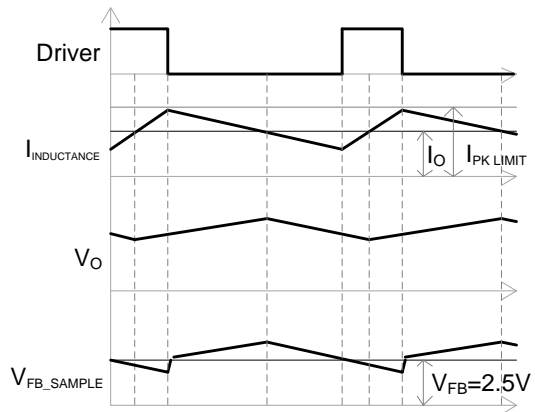

Figure 3(b). CCM

Performance Characteristics (continued)

Startup Control

An eight-stage control method is designed for soft-start function. During startup period, the minimum OFF time limit is reduced from 52.4µs to 13µs in stages. Every stage has different numbers of switching cycles (see Table 1).

Figure 4 describes the driver time sequence.

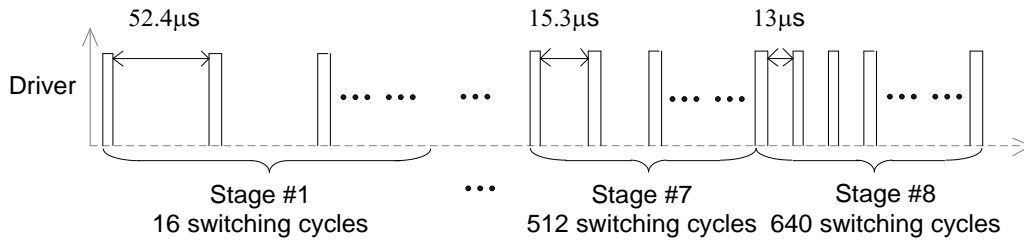

Figure 4. Driver Time Sequence in Startup Process

Stage	Minimum OFF Time (µs)	Cycles
#1	52.4	16
#2	38.9	32
#3	25.6	64
#4	22.4	128
#5	19.5	256
#6	17.1	384
#7	15.3	512
#8	13	640

Table 1. The Number of Cycles in Every Stage

Operation Frequency and Peak Current Characteristics

In order to achieve excellent efficiency performance at light load and improve overall system efficiency, the AP3928 utilizes an optimized frequency curve, as shown in Figure 5. By means of increasing MOSFET off-time, switching frequency continuously decreases as the load decreases, which is optimized for better light load efficiency. The peak current also decreases with load decreases, which can avoid audio noise when the frequency enters into audio frequency range.

The switching-frequency equation is as follows:

$$f_s = \left(\frac{V_{IN} - V_o}{V_{IN}}\right) \cdot \frac{V_o}{2 \cdot L \cdot (I_{PK} - I_o)}, \text{ for CCM}$$

$$f_s = \left(\frac{V_{IN} - V_o}{V_{IN}}\right) \cdot \frac{2 \cdot V_o \cdot I_o}{L \cdot I_{PK}^2}, \text{ for DCM}$$

The switching frequency and the peak current limit adjust as shown in the following equation:

$$I_{PK} = I_{PK_MAX} - (40mA / \mu s) \cdot (t_{OFF} - t_{MINOFF})$$

The minimal value of I_{PK} is limited internally.

Performance Characteristics (continued)

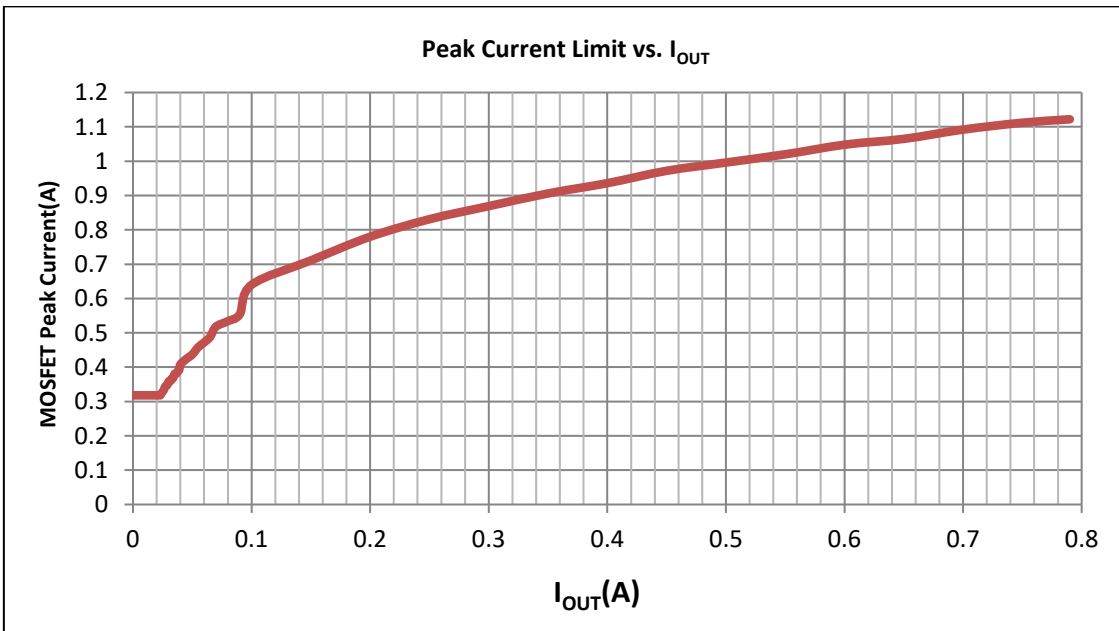
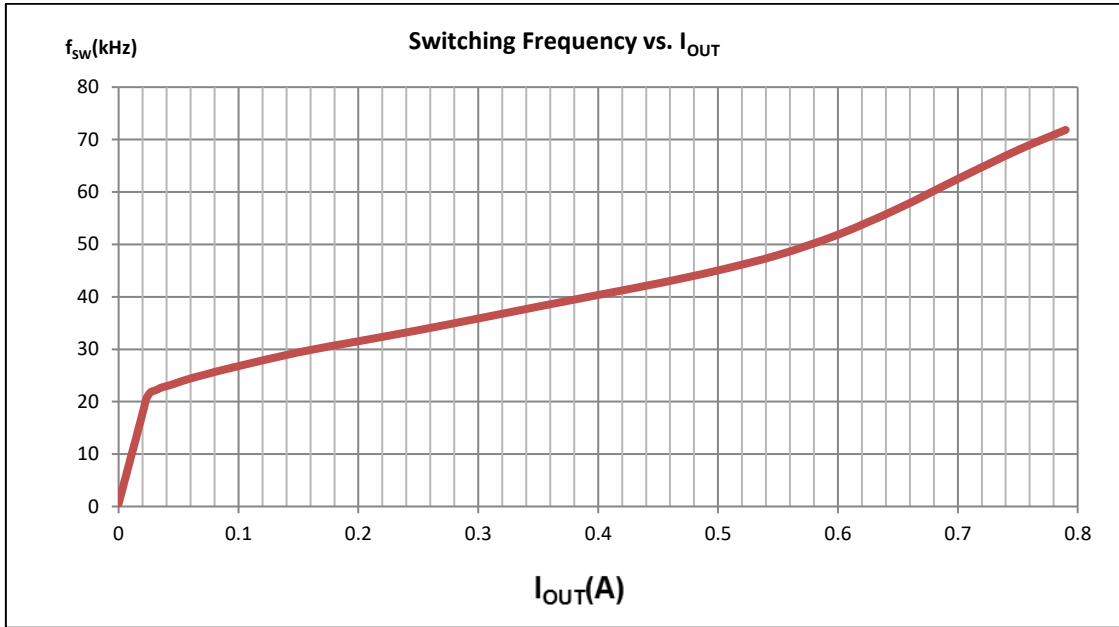

Figure 5. Frequency and Peak Current Limit Characteristic ($V_o = 18V$, $L1 = 0.47mH$)

Performance Characteristics (continued)

Overload Protection (OLP)

With the increase of load, the peak current and the switching frequency also increase. When the peak current reaches the maximum limitation, and the OFF time is the minimum OFF time, the internal OLP timer begins to count. For avoiding false triggering during startup and other load transition condition, OLP is activated only when the switching pulses reach to the OLP_counting cycles requirement.

Short-Circuit Protection (SCP)

The AP3928 shuts down when the peak current exceeds short-circuit threshold, and the AP3928 resumes operation when the fault is removed.

Note that the inductor saturation current should be higher than I_{SCP} to avoid SCP being triggered during startup. Otherwise, the device may not turn on normally.

Overtemperature Protection (OTP)

The AP3928 integrates an internal overtemperature protection function. The AP3928 shuts down when the inner junction temperature exceeds thermal shutdown threshold T_{OTP} (+150°C). After exceeding the threshold, the VCC voltage begins to drop, and when VCC voltage drops to $V_{CC_RESTART}$ (4.5V), the internal high-voltage regulator turns on to charge the external VCC capacitor.

Open-Loop Detection (OLD)

When the FB voltage drops below the open-loop detection threshold voltage V_{OLD} , the AP3928 stops working and begins a restart cycle. The open-loop detection is blanked for 64 switching cycles during startup process. Moreover, if FB pin was floating, output voltage will be fixed to 12V typically.

Overshoot Improvement

In general, there is no capacitor between FB pin and GNDP (GNDA) pin. But in some cases where strict overshoot is required, we recommend a ceramic capacitor C6 (390pF to 2.2nF) in Figure 6. In addition, adding a C6 can improve output voltage ripple as well.

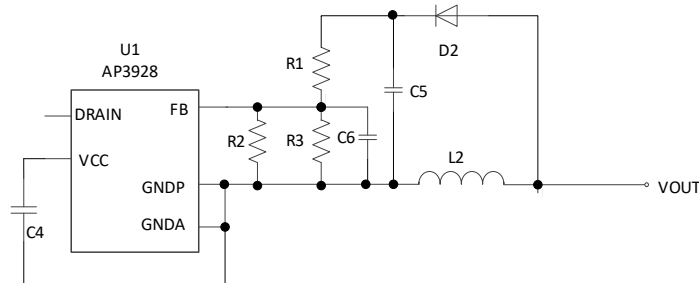
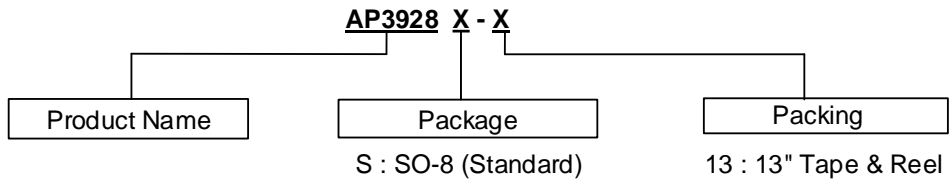

Figure 6. Overshoot Improvement

Leading-Edge Blanking (LEB)

A narrow spike on the leading edge of the current waveform can usually be observed when the power MOSFET is turned on. Normally, the leading-edge blanking time t_{LEB1} is built in to prevent false-triggering caused by the turn-on spike. But in the case of a short circuit, the leading-edge blanking time is t_{LEB2} . During this period, the current limit comparator is disabled, and the gate driver cannot be switched off.

Ordering Information



Orderable Part Number	Part Number Suffix	Package	Marking ID	Packing	
				Qty.	Carrier
AP3928S-13	-13	SO-8 (Standard)	AP3928	4000	Tape and Reel

Marking Information

Package Type: SO-8 (Standard)

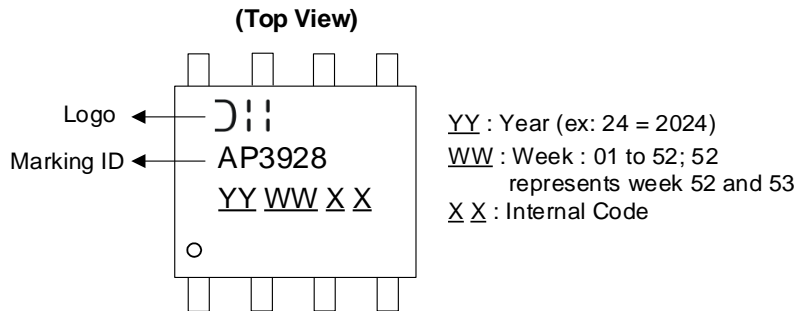

Package Outline Dimensions

Please see <http://www.diodes.com/package-outlines.html> for the latest version.

SO-8 (Standard)

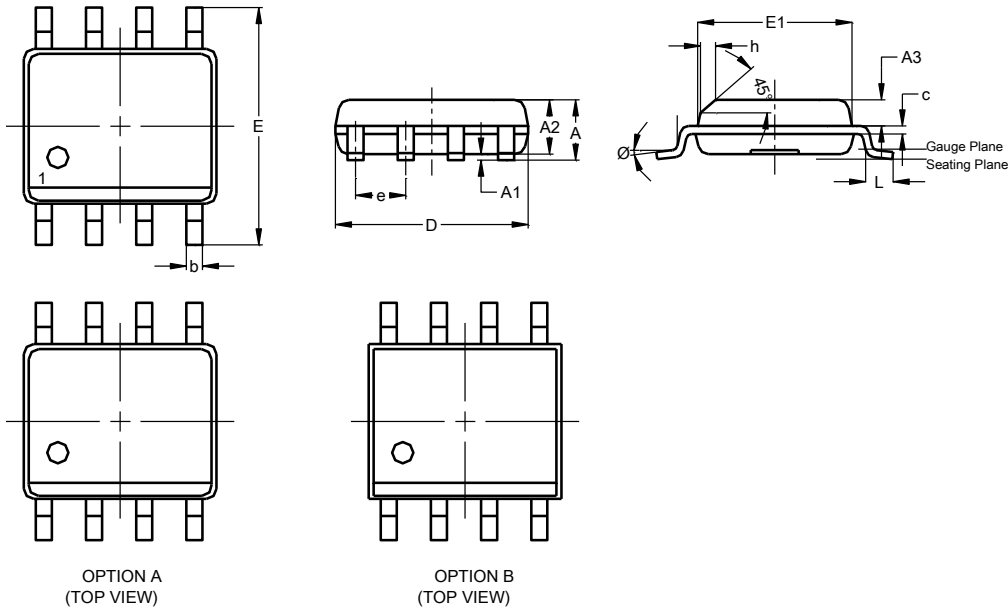

SO-8 (Standard)			
Dim	Min	Max	Typ
A	--	1.75	--
A1	0.10	0.25	--
A2	1.25	1.65	--
A3	0.50	0.70	--
b	0.30	0.51	--
c	0.15	0.25	--
D	4.80	5.00	--
E	5.80	6.20	6.00
E1	3.80	4.00	--
e	--	--	1.27
h	0.25	0.50	--
L	0.45	0.82	--
Ø	0°	8°	--
All Dimensions in mm			

Suggested Pad Layout

Please see <http://www.diodes.com/package-outlines.html> for the latest version.

SO-8 (Standard)

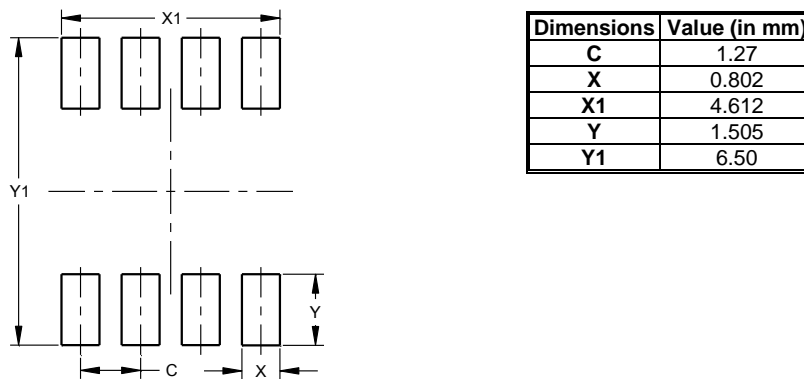

Mechanical Data

- Moisture Sensitivity: Level 3 per JESD22-A113
- Terminals: Finish – Matte Tin Plated Leads, Solderable per JESD22-B102 (E3)
- Weight: 0.076 grams (Approximate)

IMPORTANT NOTICE

1. DIODES INCORPORATED (Diodes) AND ITS SUBSIDIARIES MAKE NO WARRANTY OF ANY KIND, EXPRESS OR IMPLIED, WITH REGARDS TO ANY INFORMATION CONTAINED IN THIS DOCUMENT, INCLUDING, BUT NOT LIMITED TO, THE IMPLIED WARRANTIES OF MERCHANTABILITY, FITNESS FOR A PARTICULAR PURPOSE OR NON-INFRINGEMENT OF THIRD PARTY INTELLECTUAL PROPERTY RIGHTS (AND THEIR EQUIVALENTS UNDER THE LAWS OF ANY JURISDICTION).
2. The Information contained herein is for informational purpose only and is provided only to illustrate the operation of Diodes' products described herein and application examples. Diodes does not assume any liability arising out of the application or use of this document or any product described herein. This document is intended for skilled and technically trained engineering customers and users who design with Diodes' products. Diodes' products may be used to facilitate safety-related applications; however, in all instances customers and users are responsible for (a) selecting the appropriate Diodes products for their applications, (b) evaluating the suitability of Diodes' products for their intended applications, (c) ensuring their applications, which incorporate Diodes' products, comply the applicable legal and regulatory requirements as well as safety and functional-safety related standards, and (d) ensuring they design with appropriate safeguards (including testing, validation, quality control techniques, redundancy, malfunction prevention, and appropriate treatment for aging degradation) to minimize the risks associated with their applications.
3. Diodes assumes no liability for any application-related information, support, assistance or feedback that may be provided by Diodes from time to time. Any customer or user of this document or products described herein will assume all risks and liabilities associated with such use, and will hold Diodes and all companies whose products are represented herein or on Diodes' websites, harmless against all damages and liabilities.
4. Products described herein may be covered by one or more United States, international or foreign patents and pending patent applications. Product names and markings noted herein may also be covered by one or more United States, international or foreign trademarks and trademark applications. Diodes does not convey any license under any of its intellectual property rights or the rights of any third parties (including third parties whose products and services may be described in this document or on Diodes' website) under this document.
5. Diodes' products are provided subject to Diodes' Standard Terms and Conditions of Sale (<https://www.diodes.com/about/company/terms-and-conditions/terms-and-conditions-of-sales/>) or other applicable terms. This document does not alter or expand the applicable warranties provided by Diodes. Diodes does not warrant or accept any liability whatsoever in respect of any products purchased through unauthorized sales channel.
6. Diodes' products and technology may not be used for or incorporated into any products or systems whose manufacture, use or sale is prohibited under any applicable laws and regulations. Should customers or users use Diodes' products in contravention of any applicable laws or regulations, or for any unintended or unauthorized application, customers and users will (a) be solely responsible for any damages, losses or penalties arising in connection therewith or as a result thereof, and (b) indemnify and hold Diodes and its representatives and agents harmless against any and all claims, damages, expenses, and attorney fees arising out of, directly or indirectly, any claim relating to any noncompliance with the applicable laws and regulations, as well as any unintended or unauthorized application.
7. While efforts have been made to ensure the information contained in this document is accurate, complete and current, it may contain technical inaccuracies, omissions and typographical errors. Diodes does not warrant that information contained in this document is error-free and Diodes is under no obligation to update or otherwise correct this information. Notwithstanding the foregoing, Diodes reserves the right to make modifications, enhancements, improvements, corrections or other changes without further notice to this document and any product described herein. This document is written in English but may be translated into multiple languages for reference. Only the English version of this document is the final and determinative format released by Diodes.
8. Any unauthorized copying, modification, distribution, transmission, display or other use of this document (or any portion hereof) is prohibited. Diodes assumes no responsibility for any losses incurred by the customers or users or any third parties arising from any such unauthorized use.
9. This Notice may be periodically updated with the most recent version available at <https://www.diodes.com/about/company/terms-and-conditions/important-notice>

The Diodes logo is a registered trademark of Diodes Incorporated in the United States and other countries.
All other trademarks are the property of their respective owners.
© 2024 Diodes Incorporated. All Rights Reserved.

www.diodes.com