

ASMBJ SERIES

SURFACE MOUNT UNIDIRECTIONAL AND BIDIRECTIONAL TRANSIENT VOLTAGE SUPPRESSORS

REVERSE VOLTAGE -5.0 to 75 Volts
POWER DISSIPATION -600 Watts

FEATURES



- For surface mounted applications
- Reliable low cost construction utilizing molded plastic technique
- Typical IR less than 1uA above 10V
- Fast response time: typically less than 1.0ns for Uni-direction, less than 5.0ns for Bi-direction, from 0 Volts to BV min
- Glass Passivated Die Construction
- Automotive grade
- **Lead-Free Finish; RoHS Compliant (Notes 1 & 2)**
- **Halogen and Antimony Free. "Green" Device (Note 3)**
- **The ASMBJ SERIES are suitable for automotive applications requiring specific change control; these parts are AEC-Q101 qualified, PPAP capable, and manufactured in IATF 16949 certified facilities.**

<https://www.diodes.com/quality/product-definitions/>

MECHANICAL DATA

- Package: Molded plastic
- Package Material: Molding compound, UL Flammability classification 94V-0, (No Br. Sb. Cl.) "Halogen-free".
- Polarity: by cathode band denotes uni-directional device, non cathode band denotes bi-directional device
- Moisture Sensitivity: Level 1 per J-STD-020
- Terminals: Finish Matte Tin Plated Leads, Solderable per MIL-STD-202, Method 208 (e3)
- Weight: 0.003 ounces, 0.093 gram (Approximate)

SMB

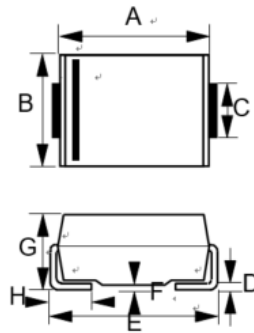

SMB		
DIM.	MIN.	MAX.
A	4.06	4.57
B	3.30	3.94
C	1.96	2.21
D	0.15	0.31
E	5.21	5.59
F	0.05	0.20
G	2.01	2.50
H	0.76	1.52

All Dimensions in millimeter

MAXIMUM RATINGS AND ELECTRICAL CHARACTERISTICS

Ratings at 25°C ambient temperature unless otherwise specified.

ABSOLUTE RATINGS

PARAMETER	SYMBOL	VALUE	UNIT
PEAK POWER DISSIPATION AT TA = 25 C, TP = 1ms (Note 4)	P _{PK}	600	W
Peak Forward Surge Current 8.3ms single half sine-wave @Tj=25°C (Note 5)	I _{FSM}	90	A
Steady State Power Dissipation with PCB	P _{M(AV)}	1.5	W
Maximum Instantaneous forward voltage at 16A (Notes 5, 6)	V _F	2.5	V
Typical Thermal Resistance	R _{θJA} R _{θJC}	90 25	°C/W
Operating Temperature Range	T _J	-55 to +175	°C
Storage Temperature Range	T _{STG}	-55 to +175	°C

Notes:

1. EU Directive 2002/95/EC (RoHS), 2011/65/EU (RoHS 2) & 2015/863/EU (RoHS 3) compliant. All applicable RoHS exemptions applied.
2. See <https://www.diodes.com/quality/lead-free/> for more information about Diodes Incorporated's definitions of Halogen- and Antimony-free, "Green" and Lead-free.
3. Halogen- and Antimony-free "Green" products are defined as those which contain <900ppm bromine, <900ppm chlorine (<1500ppm total Br + Cl) and <1000ppm antimony compounds.
4. Non-repetitive current pulse, per fig. 3 and derated above T_J= 25°C per fig.1.
5. Only for uni-directional units.
6. V_F max=2.5V at I_F=16A 300us square wave pulse.

ELECTRICAL CHARACTERISTICS

Device Uni- Directional	Device Bi- Directional	Device Marking Code		Reverse Standoff Voltage VR (V)	Breakdown Voltage VBR Volts			Max. Clamping Voltage @Ipp VC (V)	Max. Peak Pulse Current IPP (A)	Max. Reverse Leakage @ VR IR (uA)
		(UNI)	(BI)		Min.	Max.	@It (mA)			
ASMBJ5.0A	ASMBJ5.0CA	AKE	AAE	5.0	6.40	7.07	10	9.2	65.2	800
ASMBJ6.0A	ASMBJ6.0CA	AKG	AAG	6.0	6.67	7.37	10	10.3	58.3	800
ASMBJ6.5A	ASMBJ6.5CA	AKK	AAK	6.5	7.22	7.98	10	11.2	53.6	500
ASMBJ7.0A	ASMBJ7.0CA	AKM	AAM	7.0	7.78	8.60	1.0	12.0	50.0	200
ASMBJ7.5A	ASMBJ7.5CA	AKP	AAP	7.5	8.33	9.21	1.0	12.9	46.5	100
ASMBJ8.0A	ASMBJ8.0CA	AKR	AAR	8.0	8.89	9.83	1.0	13.6	44.1	50.0
ASMBJ8.5A	ASMBJ8.5CA	AKT	AAR	8.5	9.44	10.4	1.0	14.4	41.7	20.0
ASMBJ9.0A	ASMBJ9.0CA	AKV	AAV	9.0	10.0	11.1	1.0	15.4	39.0	10.0
ASMBJ10A	ASMBJ10CA	AKX	AAX	10.0	11.1	12.3	1.0	17.0	35.3	0.5
ASMBJ11A	ASMBJ11CA	AKZ	AAZ	11.0	12.2	13.5	1.0	18.2	33.0	0.5
ASMBJ12A	ASMBJ12CA	ALE	ABE	12.0	13.3	14.7	1.0	19.9	30.2	0.5
ASMBJ13A	ASMBJ13CA	ALG	ABG	13.0	14.4	15.9	1.0	21.5	27.9	0.5
ASMBJ14A	ASMBJ14CA	ALK	ABK	14.0	15.6	17.2	1.0	23.2	25.8	0.5
ASMBJ15A	ASMBJ15CA	ALM	ABM	15.0	16.7	18.5	1.0	24.4	24.0	0.5
ASMBJ16A	ASMBJ16CA	ALP	ABP	16.0	17.8	19.7	1.0	26.0	23.1	0.5
ASMBJ17A	ASMBJ17CA	ALR	ABR	17.0	18.9	20.9	1.0	27.6	21.7	0.5
ASMBJ18A	ASMBJ18CA	ALT	ABR	18.0	20.0	22.1	1.0	29.2	20.5	0.5
ASMBJ20A	ASMBJ20CA	ALV	ABV	20.0	22.2	24.5	1.0	32.4	18.5	0.5
ASMBJ22A	ASMBJ22CA	ALX	ABX	22.0	24.4	27.0	1.0	35.5	16.9	0.5
ASMBJ24A	ASMBJ24CA	ALZ	ABZ	24.0	26.7	29.5	1.0	38.9	15.4	0.5
ASMBJ26A	ASMBJ26CA	AME	ACE	26.0	28.9	31.9	1.0	42.1	14.2	0.5
ASMBJ28A	ASMBJ28CA	AMG	ACG	28.0	31.1	34.4	1.0	45.4	13.2	0.5
ASMBJ30A	ASMBJ30CA	AMK	ACK	30.0	33.3	36.8	1.0	48.4	12.4	0.5
ASMBJ33A	ASMBJ33CA	AMM	ACM	33.0	36.7	40.6	1.0	53.3	11.3	0.5
ASMBJ36A	ASMBJ36CA	AMP	ACP	36.0	40.0	44.2	1.0	58.1	10.3	0.5
ASMBJ40A	ASMBJ40CA	AMR	ACR	40.0	44.4	49.1	1.0	64.5	9.3	0.5
ASMBJ43A	ASMBJ43CA	AMT	ACR	43.0	47.8	52.8	1.0	69.4	8.6	0.5
ASMBJ45A	ASMBJ45CA	AMV	ACV	45.0	50.0	55.3	1.0	72.7	8.3	0.5
ASMBJ48A	ASMBJ48CA	AMX	ACX	48.0	53.3	58.9	1.0	77.4	7.7	0.5
ASMBJ51A	ASMBJ51CA	AMZ	ACZ	51.0	56.7	62.7	1.0	82.4	7.3	0.5
ASMBJ54A	ASMBJ54CA	ANE	ADE	54.0	60.0	66.3	1.0	87.1	6.9	0.5
ASMBJ58A	ASMBJ58CA	ANG	ADG	58.0	64.4	71.2	1.0	93.6	6.4	0.5
ASMBJ60A	ASMBJ60CA	ANK	ADK	60.0	66.7	73.7	1.0	96.8	6.2	0.5
ASMBJ61A	ASMBJ61CA	ANL	ADL	61.0	66.6	71.9	1.0	97.6	6.1	0.5
ASMBJ64A	ASMBJ64CA	ANM	ADM	64.0	71.1	78.6	1.0	103	5.8	0.5
ASMBJ70A	ASMBJ70CA	ANP	ADP	70.0	77.8	86.0	1.0	113	5.3	0.5
ASMBJ75A	ASMBJ75CA	ANR	ADR	75.0	83.3	92.1	1.0	121	4.9	0.5

Notes:

Suffix 'A' denotes 5% tolerance device.

- 1) Add suffix 'C' or 'CA' after part number to specify Bi-directional devices.
- 2) The IR limit is double for Bi-Directional devices.

**RATING AND CHARACTERISTIC CURVES
ASMBJ SERIES**

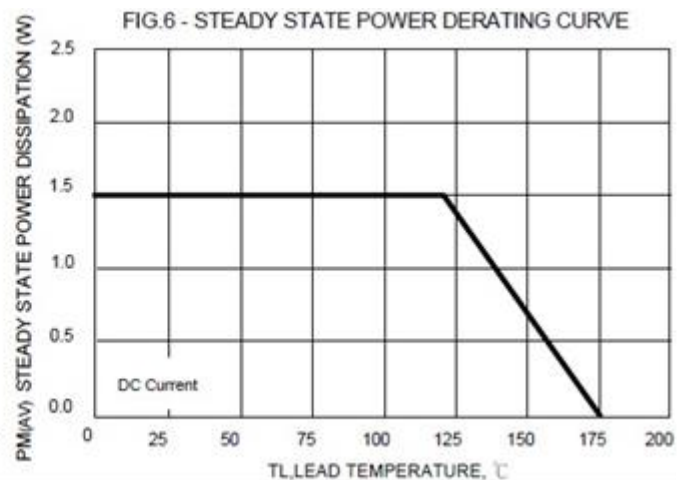
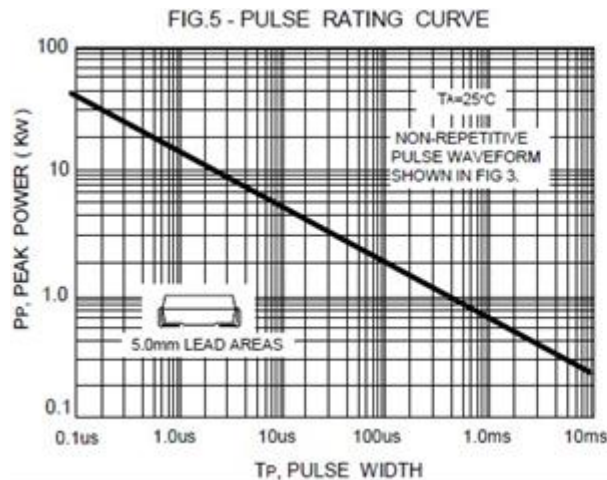
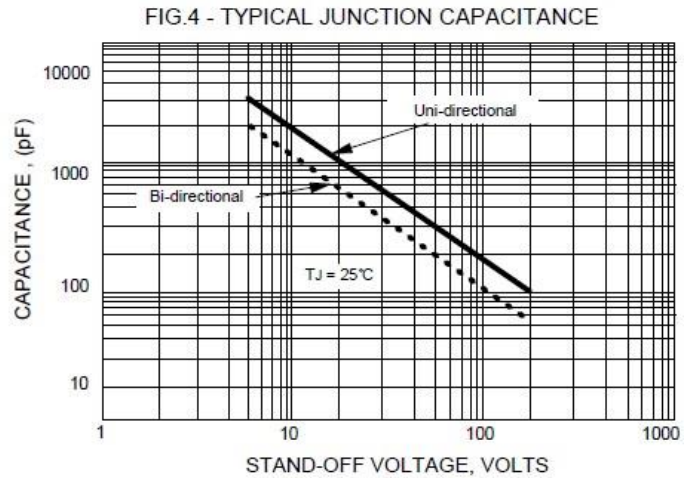
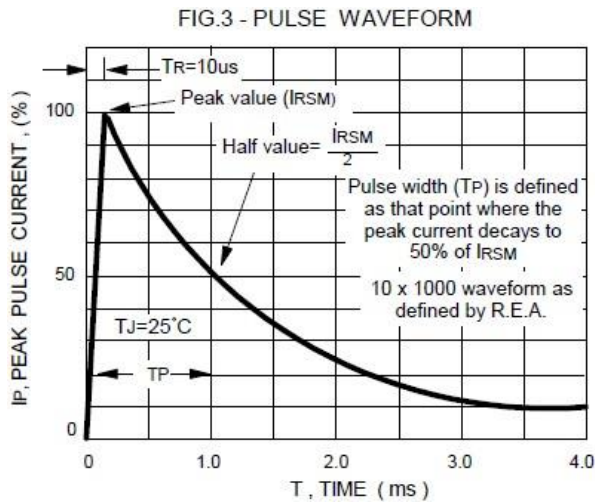
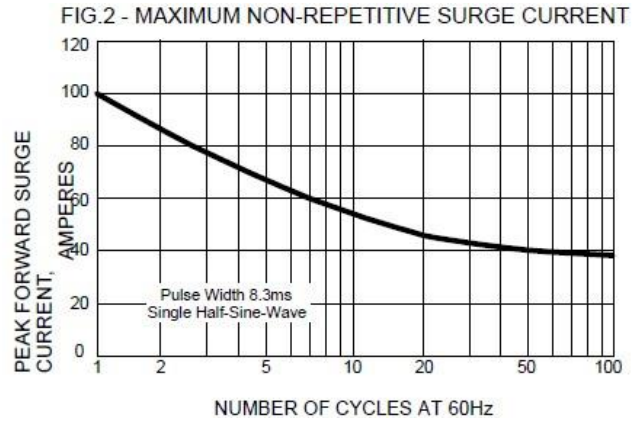
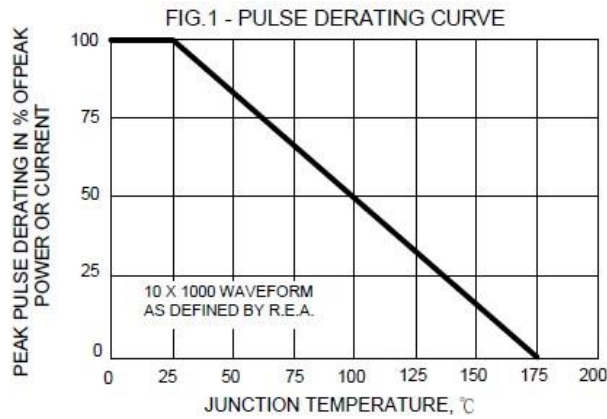

Ordering Information :

Part Number	Package	Packing	
		Qty.	Carrier
ASMBJ SERIES	SMB	3000pcs	Reel

Marking Information :

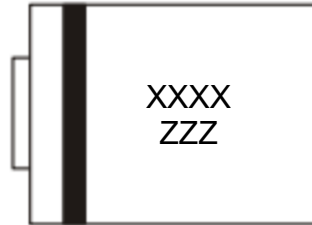

XXXX : Assembly Tracing Code
ZZZ : Product Type Marking Code
Bar Denotes Cathode Side

Packaging Information :

DEVICE	Q'TY/REEL (PCS)	REEL DIA. (INCH)	Q'TY/BOX (PCS)	Q'TY/CARTON (PCS)
ASMBJXXA ASMBJXXCA	3000	13	6K	48K

Suggested Pad Layout :

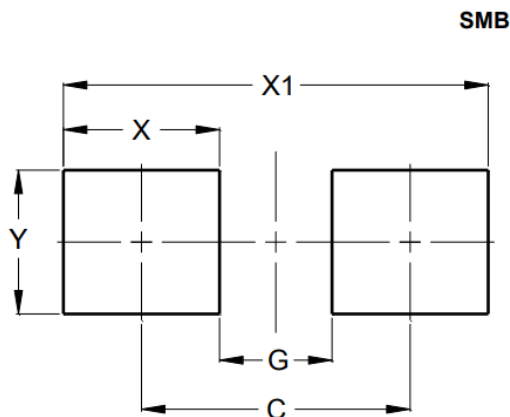

Dimensions	Value (in mm)
C	4.30
G	1.80
X	2.50
X1	6.80
Y	2.30

Note: The suggested land pattern dimensions have been provided for reference only, as actual pad layouts may vary depending on application. These dimensions may be modified based on user equipment capability or fabrication criteria. A more robust pattern may be desired for wave soldering and is calculated by adding 0.2 mm to the 'Z' dimension. For further information, please reference document IPC-7351A, Naming Convention for Standard SMT Land Patterns, and for International grid details, please see document IEC, Publication 97.

Note: For high voltage applications, the appropriate industry sector guidelines should be considered with regards to creepage and clearance distances between device Terminals and PCB tracking.

IMPORTANT NOTICE

1. DIODES INCORPORATED (Diodes) AND ITS SUBSIDIARIES MAKE NO WARRANTY OF ANY KIND, EXPRESS OR IMPLIED, WITH REGARDS TO ANY INFORMATION CONTAINED IN THIS DOCUMENT, INCLUDING, BUT NOT LIMITED TO, THE IMPLIED WARRANTIES OF MERCHANTABILITY, FITNESS FOR A PARTICULAR PURPOSE OR NON-INFRINGEMENT OF THIRD PARTY INTELLECTUAL PROPERTY RIGHTS (AND THEIR EQUIVALENTS UNDER THE LAWS OF ANY JURISDICTION).

2. The Information contained herein is for informational purpose only and is provided only to illustrate the operation of Diodes' products described herein and application examples. Diodes does not assume any liability arising out of the application or use of this document or any product described herein. This document is intended for skilled and technically trained engineering customers and users who design with Diodes' products. Diodes' products may be used to facilitate safety-related applications; however, in all instances customers and users are responsible for (a) selecting the appropriate Diodes products for their applications, (b) evaluating the suitability of Diodes' products for their intended applications, (c) ensuring their applications, which incorporate Diodes' products, comply the applicable legal and regulatory requirements as well as safety and functional-safety related standards, and (d) ensuring they design with appropriate safeguards (including testing, validation, quality control techniques, redundancy, malfunction prevention, and appropriate treatment for aging degradation) to minimize the risks associated with their applications.

3. Diodes assumes no liability for any application-related information, support, assistance or feedback that may be provided by Diodes from time to time. Any customer or user of this document or products described herein will assume all risks and liabilities associated with such use, and will hold Diodes and all companies whose products are represented herein or on Diodes' websites, harmless against all damages and liabilities.

4. Products described herein may be covered by one or more United States, international or foreign patents and pending patent applications. Product names and markings noted herein may also be covered by one or more United States, international or foreign trademarks and trademark applications. Diodes does not convey any license under any of its intellectual property rights or the rights of any third parties (including third parties whose products and services may be described in this document or on Diodes' website) under this document.

5. Diodes' products are provided subject to Diodes' Standard Terms and Conditions of Sale (<https://www.diodes.com/about/company/terms-and-conditions/terms-and-conditions-of-sales/>) or other applicable terms. This document does not alter or expand the applicable warranties provided by Diodes. Diodes does not warrant or accept any liability whatsoever in respect of any products purchased through unauthorized sales channel.

6. Diodes' products and technology may not be used for or incorporated into any products or systems whose manufacture, use or sale is prohibited under any applicable laws and regulations. Should customers or users use Diodes' products in contravention of any applicable laws or regulations, or for any unintended or unauthorized application, customers and users will (a) be solely responsible for any damages, losses or penalties arising in connection therewith or as a result thereof, and (b) indemnify and hold Diodes and its representatives and agents harmless against any and all claims, damages, expenses, and attorney fees arising out of, directly or indirectly, any claim relating to any noncompliance with the applicable laws and regulations, as well as any unintended or unauthorized application.

7. While efforts have been made to ensure the information contained in this document is accurate, complete and current, it may contain technical inaccuracies, omissions and typographical errors. Diodes does not warrant that information contained in this document is error-free and Diodes is under no obligation to update or otherwise correct this information. Notwithstanding the foregoing, Diodes reserves the right to make modifications, enhancements, improvements, corrections or other changes without further notice to this document and any product described herein. This document is written in English but may be translated into multiple languages for reference. Only the English version of this document is the final and determinative format released by Diodes.

8. Any unauthorized copying, modification, distribution, transmission, display or other use of this document (or any portion hereof) is prohibited. Diodes assumes no responsibility for any losses incurred by the customers or users or any third parties arising from any such unauthorized use.

9. This Notice may be periodically updated with the most recent version available at <https://www.diodes.com/about/company/terms-and-conditions/important-notice>

The Diodes logo is a registered trademark of Diodes Incorporated in the United States and other countries.

All other trademarks are the property of their respective owners.

© 2023 Diodes Incorporated. All Rights Reserved.

www.diodes.com