

## Description

The AZ39150 is low dropout three-terminal regulator with a typical dropout of 375mV at 1.5A output current.

The AZ39150 provides current limit and thermal shutdown. On-chip thermal shutdown provides protection against any combination of high current and ambient temperature that would create excessive junction temperatures.

The AZ39150 is available for 3.3V, 5.0V and 12V versions now. It is available in the industry standard TO-220-3, TO-263-3, TO-252-2 (1), TO-252-2 (2), TO-252-2 (3) and TO-252-2 (4) power packages.

## Features

- Minimum Guaranteed Output Current: 1.5A
- Dropout Voltage: 375mV at  $I_{OUT} = 1.5A$
- Output Accuracy: 1%
- Low Ground Current
- Internal Current Limit and Thermal Protection
- Reversed-battery and Reversed-lead Insertion Protection
- Fast Transient Response
- **For automotive applications requiring specific change control (i.e. parts qualified to AEC-Q100/101/200, PPAP capable, and manufactured in IATF 16949 certified facilities), please [contact us](#) or your local Diodes representative. <https://www.diodes.com/quality/product-definitions/>**

## Applications

- LCD TV
- Set Top Box
- LCD Monitor
- SMPS Post Regulator
- Laptop, Palmtop and Notebook
- Portable Instrumentation
- USB Power Supply

## Pin Assignments

(Top View)

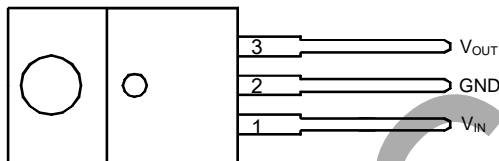

TO-220-3

(Top View)

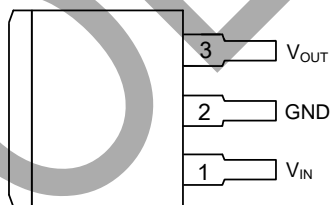

TO-263-3 (S Package)

(Top View)

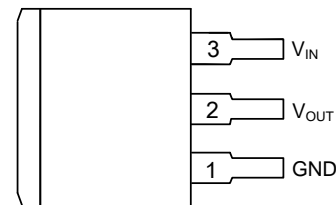

TO-263-3 (SA Package)

(Top View)

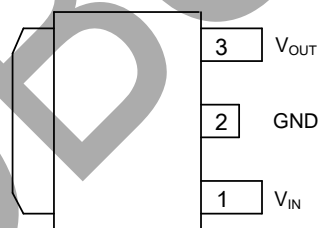

TO-252-2 (1)

(Top View)

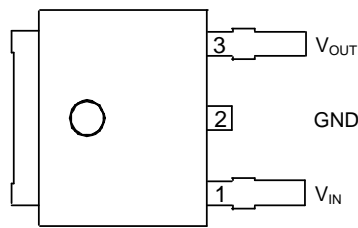

TO-252-2 (2)

(Top View)

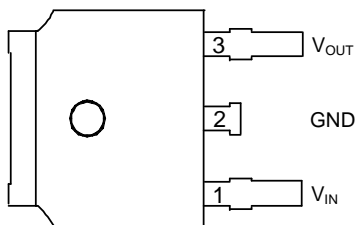

TO-252-2 (3)

(Top View)

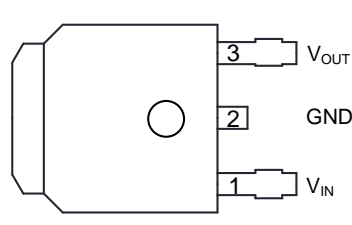

TO-252-2 (4)

OBSOLETE - PART DISCONTINUED

**Typical Applications Circuit**

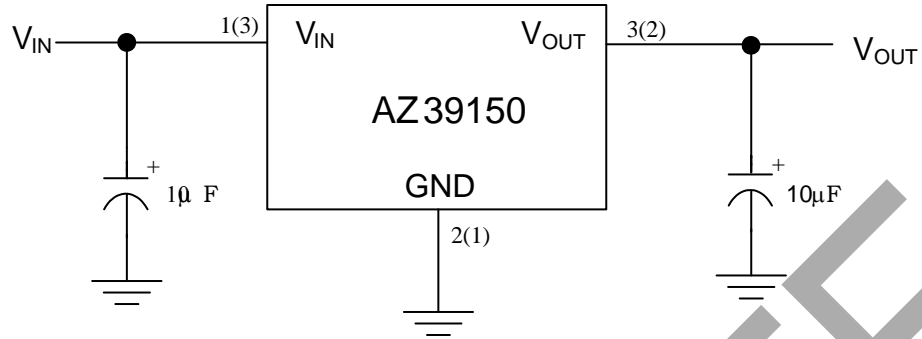

A(B)  
A: TO-220-3, TO-263-3 (S), TO-252-2 (1)/(2)/(3)/(4)  
B: TO-263-3 (SA)

**Pin Description**

Pin Number		Pin Name	Function
TO-220-3 / TO-263-3 (S) TO-252-2 (1)/(2)/(3)/(4)	TO-263-3 (SA)		
1	3	V <sub>IN</sub>	Unregulated input.
2	1	GND	The ground pin. This pin and TAB are internally connected.
3	2	V <sub>OUT</sub>	Regulated output.

**Functional Block Diagram**

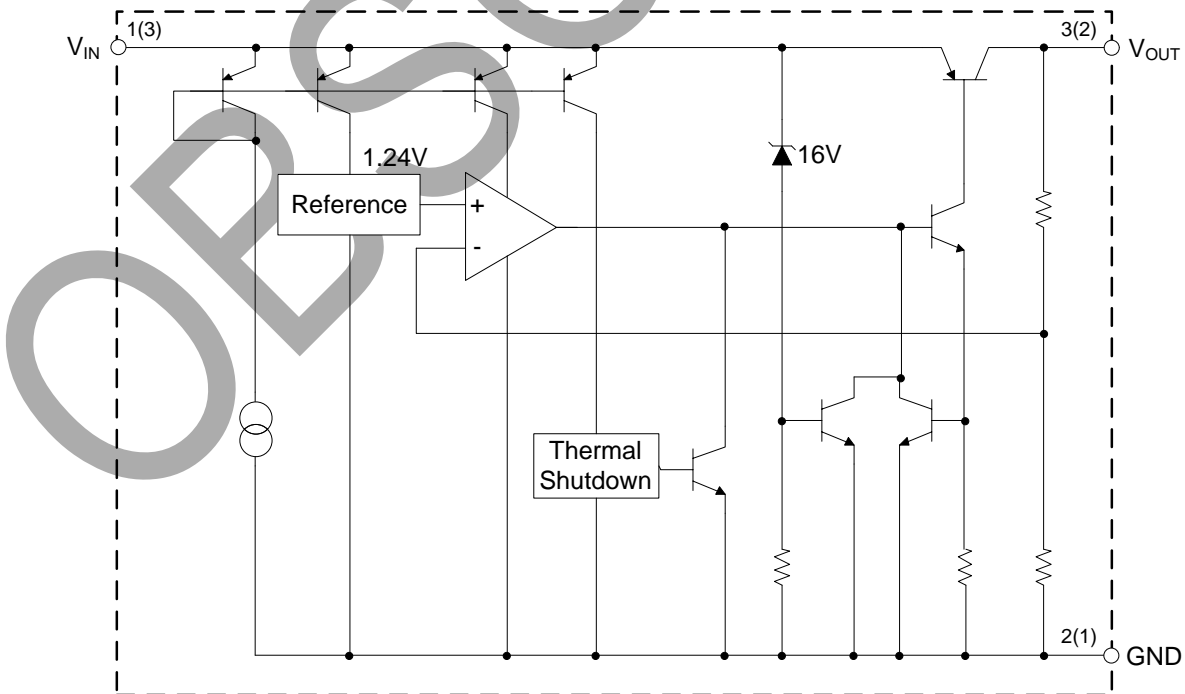

A(B)  
A: TO-220-3, TO-263-3 (S), TO-252-2 (1)/(2)/(3)/(4)  
B: TO-263-3 (SA)

OBSOLETE - PART DISCONTINUED

**Absolute Maximum Ratings** (Note 1)

Symbol	Parameter	Rating	Unit
V <sub>IN</sub>	Supply Voltage	15	V
T <sub>J</sub>	Maximum Operating Junction Temperature	+150	°C
T <sub>STG</sub>	Storage Temperature Range	-65 to +150	°C
T <sub>LEAD</sub>	Lead Temperature (Soldering, 10sec)	+300	°C
—	ESD (Machine Model)	300	V

Note: 1. Stresses greater than those listed under *Absolute Maximum Ratings* can cause permanent damage to the device. These are stress ratings only, and functional operation of the device at these or any other conditions beyond those indicated under *Recommended Operating Conditions* is not implied. Exposure to *Absolute Maximum Ratings* for extended periods can affect device reliability.

**Recommended Operating Conditions**

Symbol	Parameter	Min	Max	Unit
V <sub>IN</sub>	Supply Voltage	—	13.2	V
T <sub>J</sub>	Operating Junction Temperature	-40	+125	°C

OBSOLETE

OBSOLETE - PART DISCONTINUED

**Electrical Characteristics-3.3V** (Operating Conditions:  $V_{IN} = 4.3V$ ,  $I_{OUT} = 10mA$ ,  $C_{IN} = 10\mu F$ ,  $C_{OUT} = 10\mu F$ ,  $T_J = +25^\circ C$ , unless otherwise specified. The **Boldface** applies over  $-40^\circ C \leq T_J \leq +125^\circ C$ .)

Symbol	Parameter	Conditions	Min	Typ	Max	Unit	
$V_{OUT}$	Output Voltage	$I_{OUT} = 10mA$	3.27	3.3	3.33	V	
		$10mA \leq I_{OUT} \leq 1.5A$ , $4.3V \leq V_{IN} \leq 8V$	<b>3.23</b>	<b>3.3</b>	<b>3.37</b>	V	
$V_{RLINE}$	Line Regulation	$I_{OUT} = 10mA$ , $4.3V \leq V_{IN} \leq 8V$	—	2	17	mV	
$V_{RLOAD}$	Load Regulation	$V_{IN} = 4.3V$ , $10mA \leq I_{OUT} \leq 1.5A$	—	6.6	<b>33</b>	mV	
$\Delta V_{OUT}/\Delta T$	Output Voltage Temperature Coefficient	$I_{OUT} = 10mA$	—	<b>66</b>	<b>330</b>	$\mu V/^\circ C$	
$V_{DROP}$	Dropout Voltage (Note 2)	$\Delta V_{OUT} = 1\%$	$I_{OUT} = 100mA$	—	80	<b>200</b>	mV
			$I_{OUT} = 750mA$	—	260	—	mV
			$I_{OUT} = 1.5A$	—	375	500	mV
$I_{GND}$	Ground Current	$I_{OUT} = 750mA$ , $V_{IN} = 4.3V$	—	4	<b>20</b>	mA	
		$I_{OUT} = 1.5A$ , $V_{IN} = 4.3V$	—	17	—	mA	
$I_{LIMIT}$	Current Limit	$V_{OUT} = 0V$ (Note 3)	2.0	2.8	—	A	
$I_{LOAD (MIN)}$	Minimum Load Current	—	—	7	10	mA	
—	Output Noise Voltage (rms)	10Hz to 100kHz, $I_{OUT} = 100mA$ , $C_{OUT} = 10\mu F$	—	400	—	$\mu V$	

- Notes:
2. Dropout voltage is defined as the input-to-output differential when the output voltage drops to 99% of its nominal value which is measured at  $V_{OUT}+1V$  applied to  $V_{IN}$ .
  3.  $V_{IN} = V_{OUT(NOMINAL)} + 1V$ .

OBSOLETE

OBsolete - PART DISCONTINUED

**Electrical Characteristics-5.0V** (Operating Conditions:  $V_{IN} = 6V$ ,  $I_{OUT} = 10mA$ ,  $C_{IN} = 10\mu F$ ,  $C_{OUT} = 10\mu F$ ,  $T_J = +25^\circ C$ , unless otherwise specified. The **Boldface** applies over  $-40^\circ C \leq T_J \leq +125^\circ C$ .)

Symbol	Parameter	Conditions	Min	Typ	Max	Unit	
$V_{OUT}$	Output Voltage	$I_{OUT} = 10mA$	4.95	5.0	5.05	V	
		$10mA \leq I_{OUT} \leq 1.5A$ , $6V \leq V_{IN} \leq 8V$	<b>4.90</b>	<b>5.0</b>	<b>5.10</b>	V	
$V_{RLINE}$	Line Regulation	$I_{OUT} = 10mA$ , $6V \leq V_{IN} \leq 8V$	—	3	25	mV	
$V_{RLOAD}$	Load Regulation	$V_{IN} = 6V$ , $10mA \leq I_{OUT} \leq 1.5A$	—	10	50	mV	
$\Delta V_{OUT}/\Delta T$	Output Voltage Temperature Coefficient	$I_{OUT} = 10mA$	—	<b>100</b>	<b>500</b>	$\mu V/^\circ C$	
$V_{DROP}$	Dropout Voltage (Note 2)	$\Delta V_{OUT} = 1\%$	$I_{OUT} = 100mA$	—	80	<b>200</b>	mV
			$I_{OUT} = 750mA$	—	260	—	mV
			$I_{OUT} = 1.5A$	—	375	500	mV
$I_{GND}$	Ground Current	$I_{OUT} = 750mA$ , $V_{IN} = 6V$	—	4	<b>20</b>	mA	
		$I_{OUT} = 1.5A$ , $V_{IN} = 6V$	—	17	—	mA	
$I_{LIMIT}$	Current Limit	$V_{OUT} = 0V$ (Note 3)	2.0	2.8	—	A	
$I_{LOAD (MIN)}$	Minimum Load Current	—	—	7	10	mA	
—	Output Noise Voltage (rms)	10Hz to 100kHz, $I_{OUT} = 100mA$ , $C_{OUT} = 10\mu F$	—	400	—	$\mu V$	

- Notes:
2. Dropout voltage is defined as the input-to-output differential when the output voltage drops to 99% of its nominal value which is measured at  $V_{OUT}+1V$  applied to  $V_{IN}$ .
  3.  $V_{IN} = V_{OUT(NOMINAL)} + 1V$ .

OBSOLETE

OBSOLETE - PART DISCONTINUED

**Electrical Characteristics-12V** (Operating Conditions:  $V_{IN} = 13V$ ,  $I_{OUT} = 10mA$ ,  $C_{IN} = 10\mu F$ ,  $C_{OUT} = 10\mu F$ ,  $T_J = +25^\circ C$ , unless otherwise specified. The **Boldface** applies over  $-40^\circ C \leq T_J \leq +125^\circ C$ .)

Symbol	Parameter	Conditions	Min	Typ	Max	Unit	
$V_{OUT}$	Output Voltage	$I_{OUT} = 10mA$	11.88	12.0	12.12	V	
		$10mA \leq I_{OUT} \leq 1.5A$ , $13V \leq V_{IN} \leq 15V$	<b>11.76</b>	<b>12.0</b>	<b>12.24</b>	V	
$V_{RLINE}$	Line Regulation	$I_{OUT} = 10mA$ , $13V \leq V_{IN} \leq 15V$	—	3	25	mV	
$V_{RLOAD}$	Load Regulation	$V_{IN} = 13V$ , $10mA \leq I_{OUT} \leq 1.5A$	—	10	50	mV	
$\Delta V_{OUT}/\Delta T$	Output Voltage Temperature Coefficient	$I_{OUT} = 10mA$	—	<b>100</b>	<b>500</b>	$\mu V/^\circ C$	
$V_{DROP}$	Dropout Voltage (Note 2)	$\Delta V_{OUT} = 1\%$	$I_{OUT} = 100mA$	—	80	<b>200</b>	mV
			$I_{OUT} = 750mA$	—	260	—	mV
			$I_{OUT} = 1.5A$	—	375	500	mV
$I_{GND}$	Ground Current	$I_{OUT} = 750mA$ , $V_{IN} = 13V$	—	4	<b>20</b>	mA	
		$I_{OUT} = 1.5A$ , $V_{IN} = 13V$	—	17	—	mA	
$I_{LIMIT}$	Current Limit	$V_{OUT} = 0V$ (Note 3)	2.0	2.8	—	A	
$I_{LOAD (MIN)}$	Minimum Load Current	—	—	7	10	mA	
—	Output Noise Voltage (rms)	10Hz to 100kHz, $I_{OUT} = 100mA$ , $C_{OUT} = 10\mu F$	—	400	—	$\mu V$	

- Notes:
- Dropout voltage is defined as the input-to-output differential when the output voltage drops to 99% of its nominal value which is measured at  $V_{OUT}+1V$  applied to  $V_{IN}$ .
  - $V_{IN} = V_{OUT(NOMINAL)} + 1V$ .

OBSOLETE

**Performance Characteristics**

**Dropout Voltage vs. Output Current**

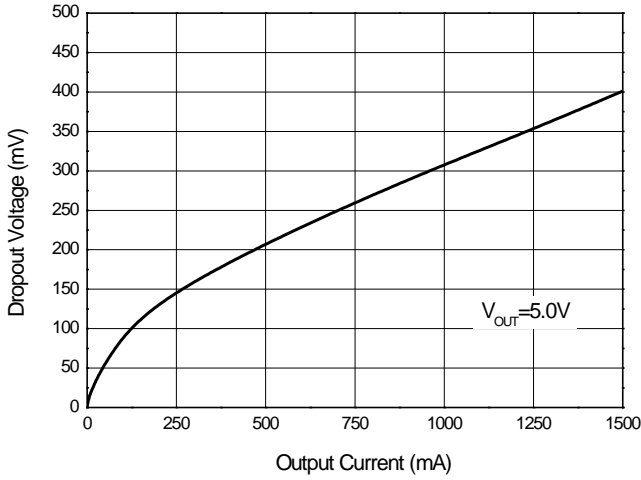

**Dropout Voltage vs. Temperature**

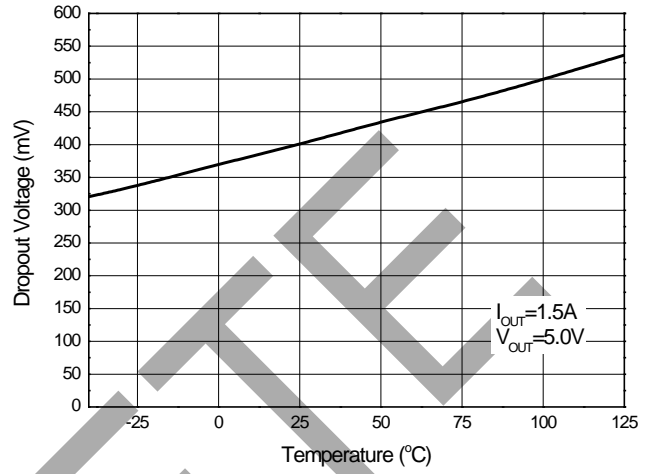

**Ground Current vs. Output Current**

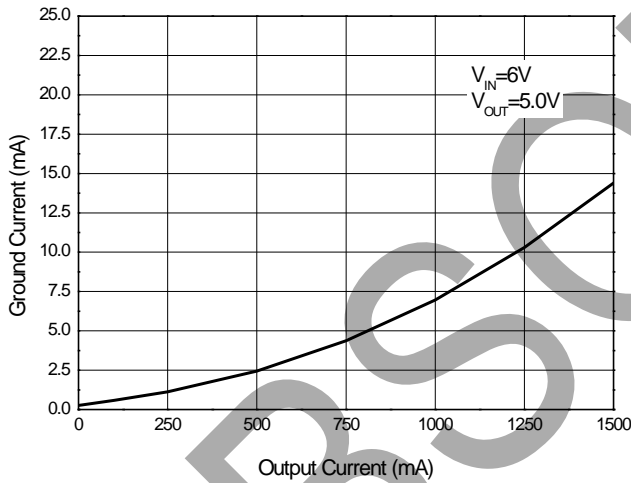

**Ground Current vs. Supply Voltage**

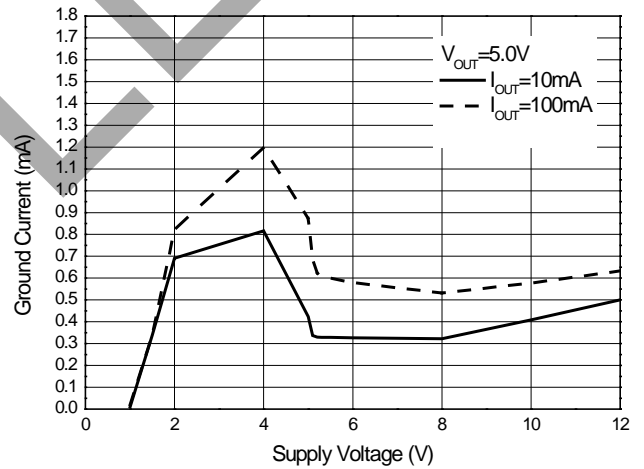

**Ground Current vs. Supply Voltage**

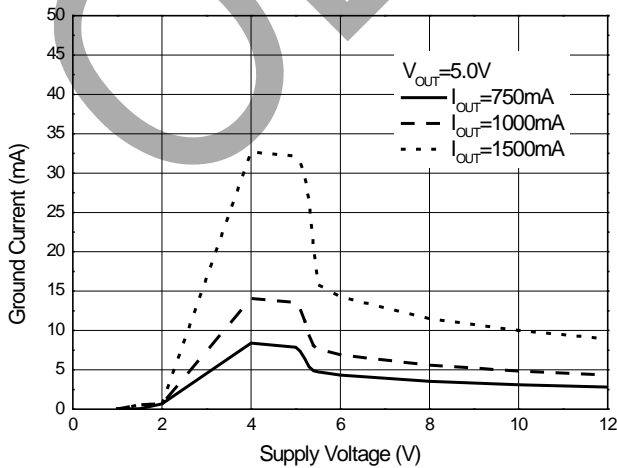

**Ground Current vs. Temperature**

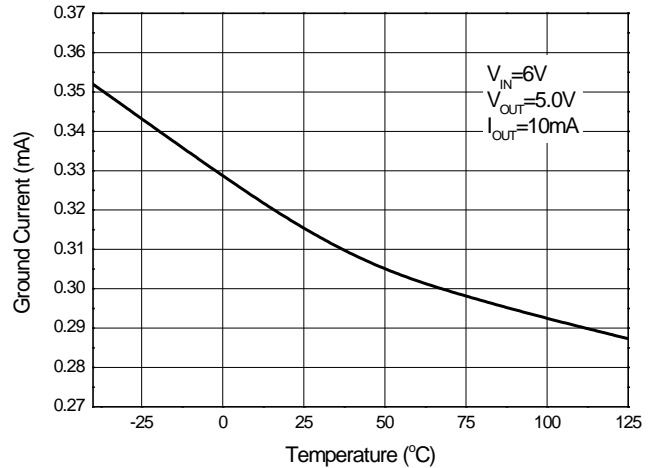

OBSOLETE - PART DISCONTINUED

**Performance Characteristics** (continued)

**Ground Current vs. Temperature**

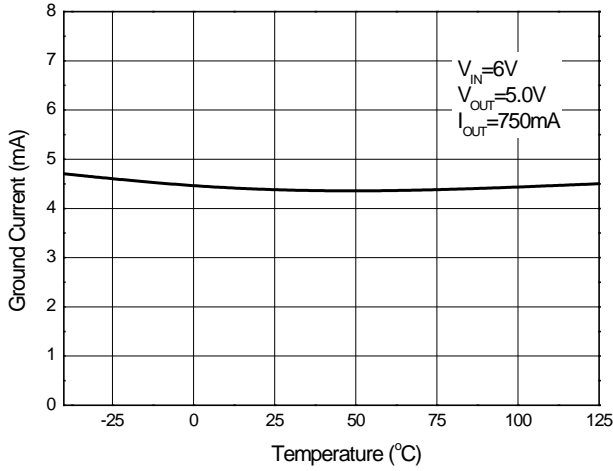

**Ground Current vs. Temperature**

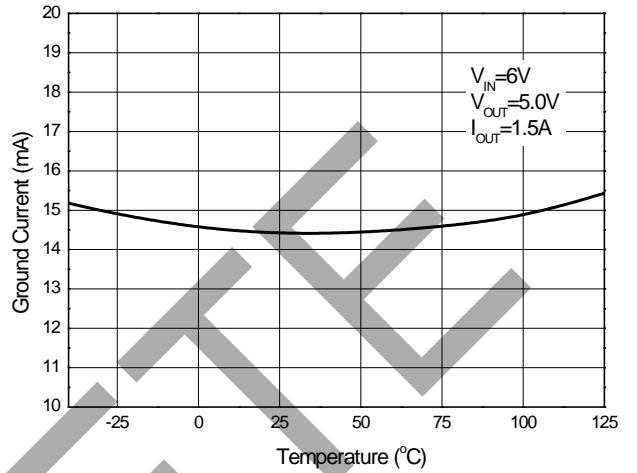

**Output Voltage vs. Temperature**

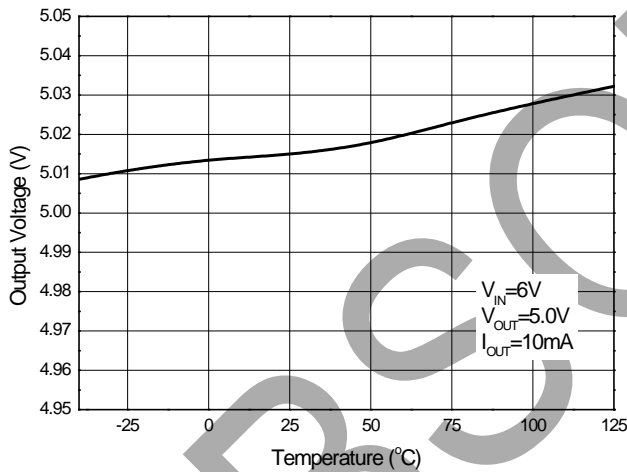

**Load Transient**

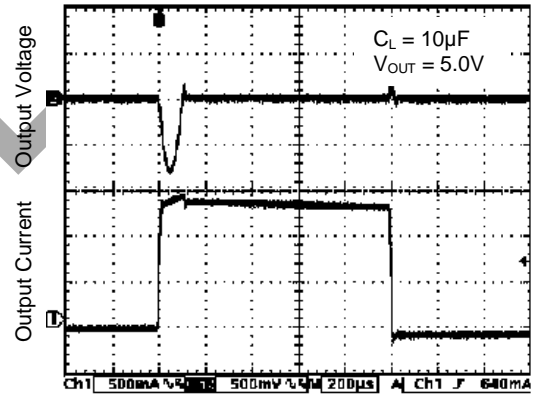

**Load Transient**

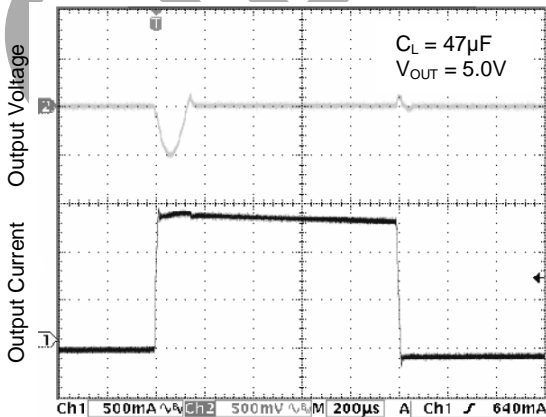

**Line Transient**

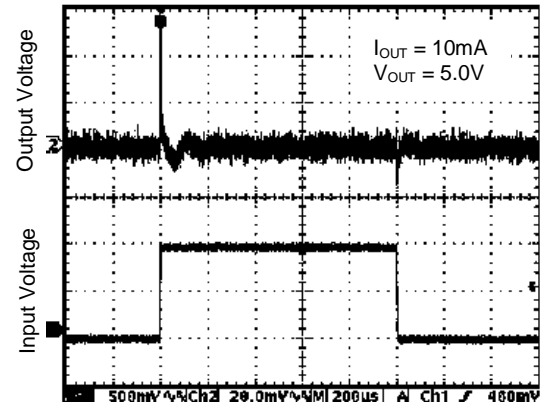

OBSOLETE - PART DISCONTINUED



**Ordering Information**

**AZ39150 X - X X X**

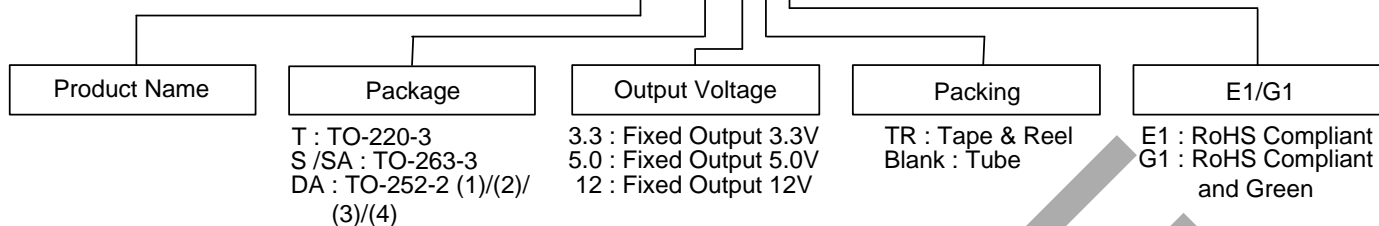

Package	Temperature Range	Part Number		Marking ID		Packing
		RoHS Compliant	RoHS Compliant and Green	RoHS Compliant	RoHS Compliant and Green	
TO-220-3	-40 to +125°C	AZ39150T-3.3E1	AZ39150T-3.3G1	AZ39150T-3.3E1	AZ39150T-3.3G1	Tube
		AZ39150T-5.0E1	AZ39150T-5.0G1	AZ39150T-5.0E1	AZ39150T-5.0G1	Tube
		AZ39150T-12E1	—	AZ39150T-12E1	—	Tube
TO-263-3 (S)	-40 to +125°C	AZ39150S-3.3E1	AZ39150S-3.3G1	AZ39150S-3.3E1	AZ39150S-3.3G1	Tube
		AZ39150S-3.3TRE1	AZ39150S-3.3TRG1	AZ39150S-3.3E1	AZ39150S-3.3G1	Tape & Reel
		AZ39150S-5.0E1	AZ39150S-5.0G1	AZ39150S-5.0E1	AZ39150S-5.0G1	Tube
		AZ39150S-5.0TRE1	AZ39150S-5.0TRG1	AZ39150S-5.0E1	AZ39150S-5.0G1	Tape & Reel
		AZ39150S-12E1	—	AZ39150S-12E1	—	Tube
		AZ39150S-12TRE1	—	AZ39150S-12E1	—	Tape & Reel
TO-263-3 (SA)	-40 to +125°C	—	AZ39150SA-3.3TRG1	—	AZ39150SA-3.3G1	Tape & Reel
		—	AZ39150SA-5.0TRG1	—	AZ39150SA-5.0G1	Tape & Reel
		—	AZ39150SA-12TRG1	—	AZ39150SA-12G1	Tape & Reel
TO-252-2 (1)/(2)/(3)/(4)	-40 to +125°C	—	AZ39150DA-3.3TRG1	—	AZ39150DA-3.3G1	Tape & Reel
		—	AZ39150DA-5.0TRG1	—	AZ39150DA-5.0G1	Tape & Reel
		—	AZ39150DA-12TRG1	—	AZ39150DA-12G1	Tape & Reel

OBSOLETE - PART DISCONTINUED

**Package Outline Dimensions** (All dimensions in mm(inch).)

Please see <http://www.diodes.com/package-outlines.html> for the latest version.

(1) Package Type: TO-220-3

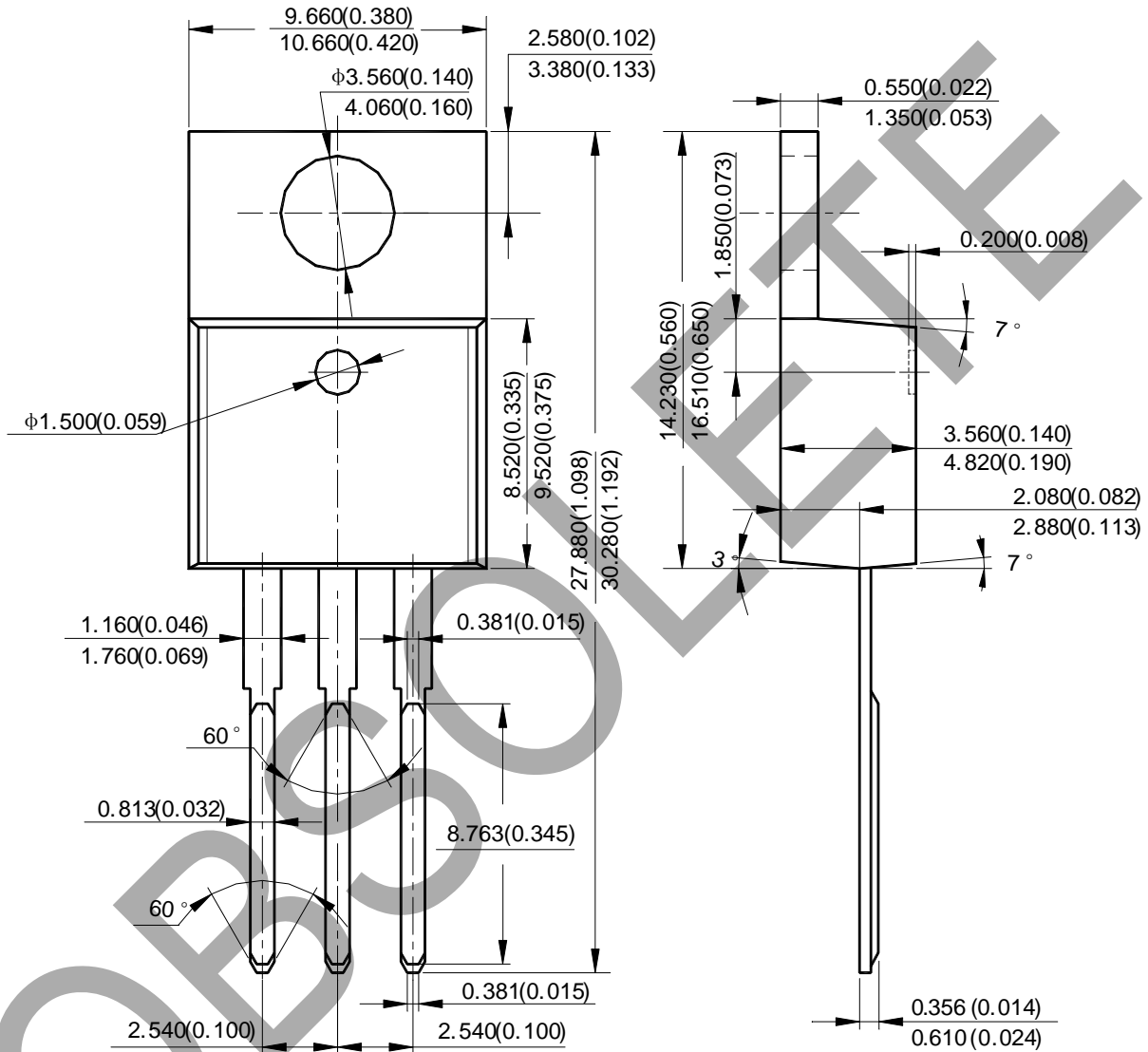

OBSOLETE - PART DISCONTINUED

**Package Outline Dimensions** (All dimensions in mm(inch) (continued))

Please see <http://www.diodes.com/package-outlines.html> for the latest version.

(2) Package Type: TO-263-3

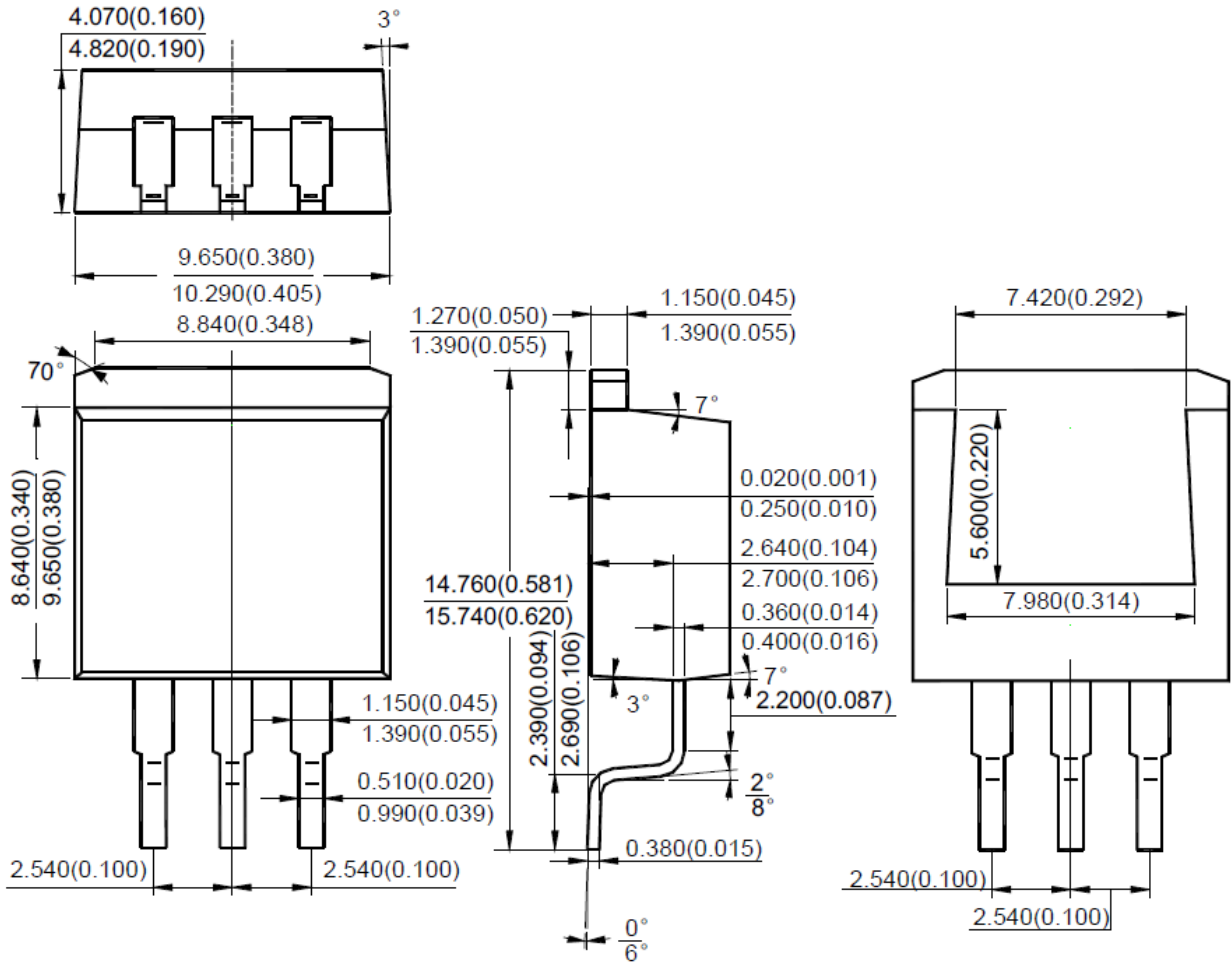

OBSOLETE - PART DISCONTINUED

**Package Outline Dimensions** (All dimensions in mm(inch) (continued))

Please see <http://www.diodes.com/package-outlines.html> for the latest version.

(3) Package Type: TO-252-2 (1)

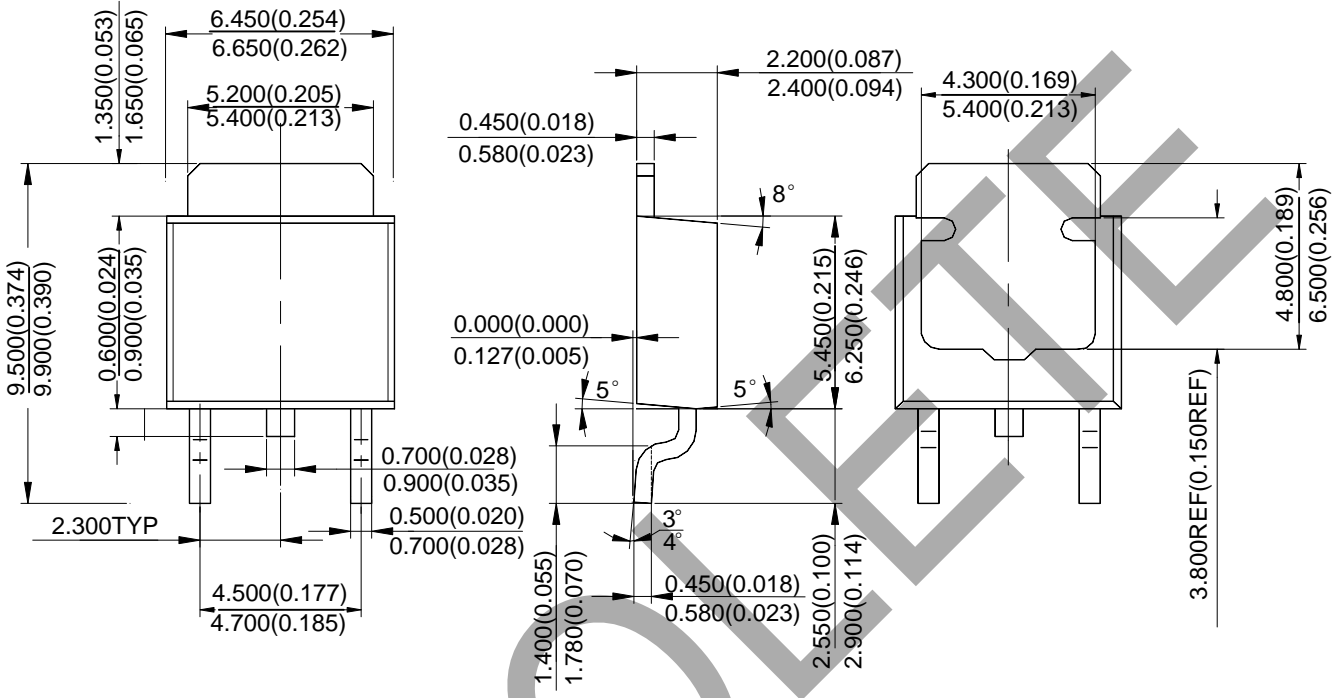

OBSOLETE - PART DISCONTINUED

OBSOLETE

**Package Outline Dimensions** (All dimensions in mm(inch) (continued))

Please see <http://www.diodes.com/package-outlines.html> for the latest version.

**(4) Package Type: TO-252-2 (2)**

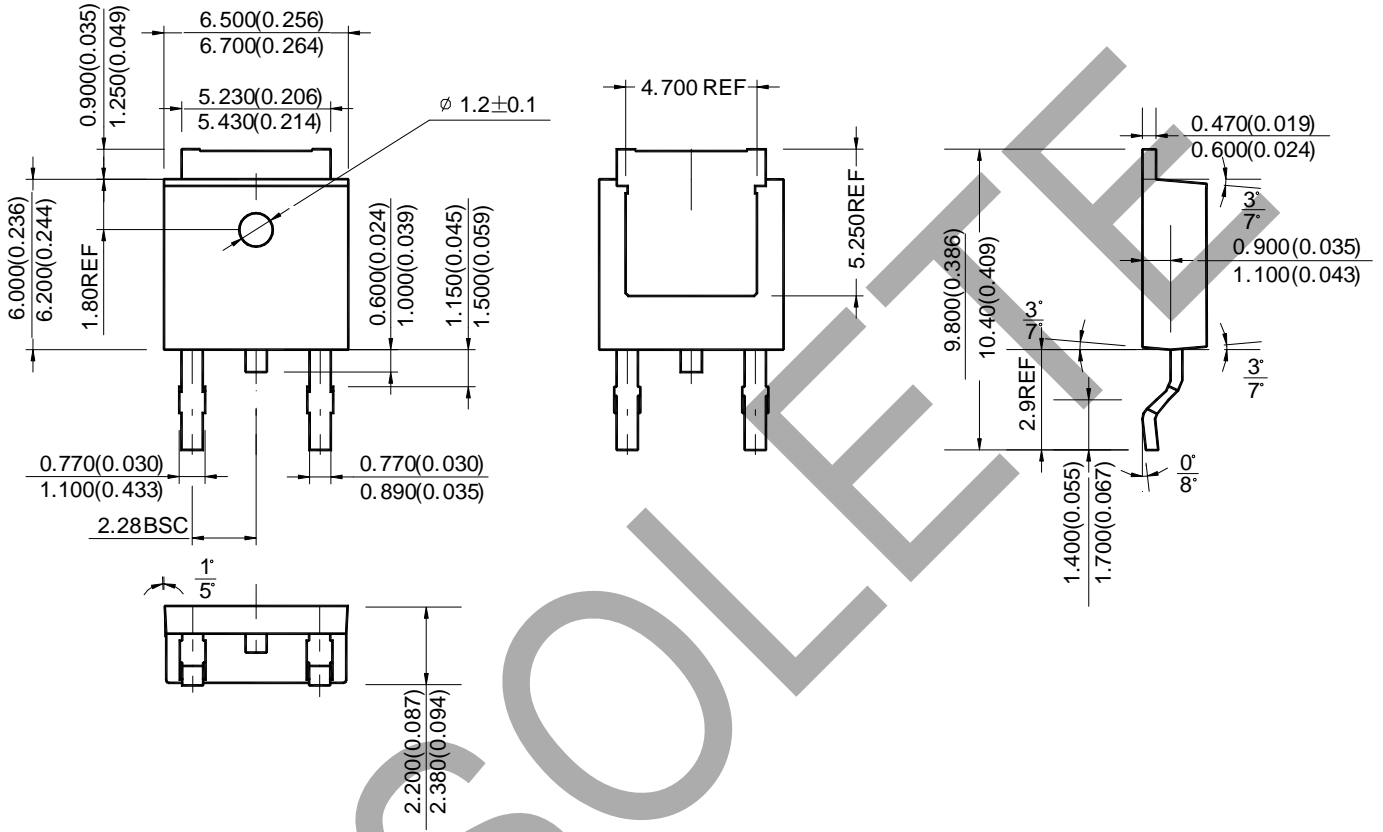

OBSOLETE - PART DISCONTINUED

OBSOLETE

**Package Outline Dimensions** (All dimensions in mm(inch) (continued))

Please see <http://www.diodes.com/package-outlines.html> for the latest version.

(5) Package Type: TO-252-2 (3)

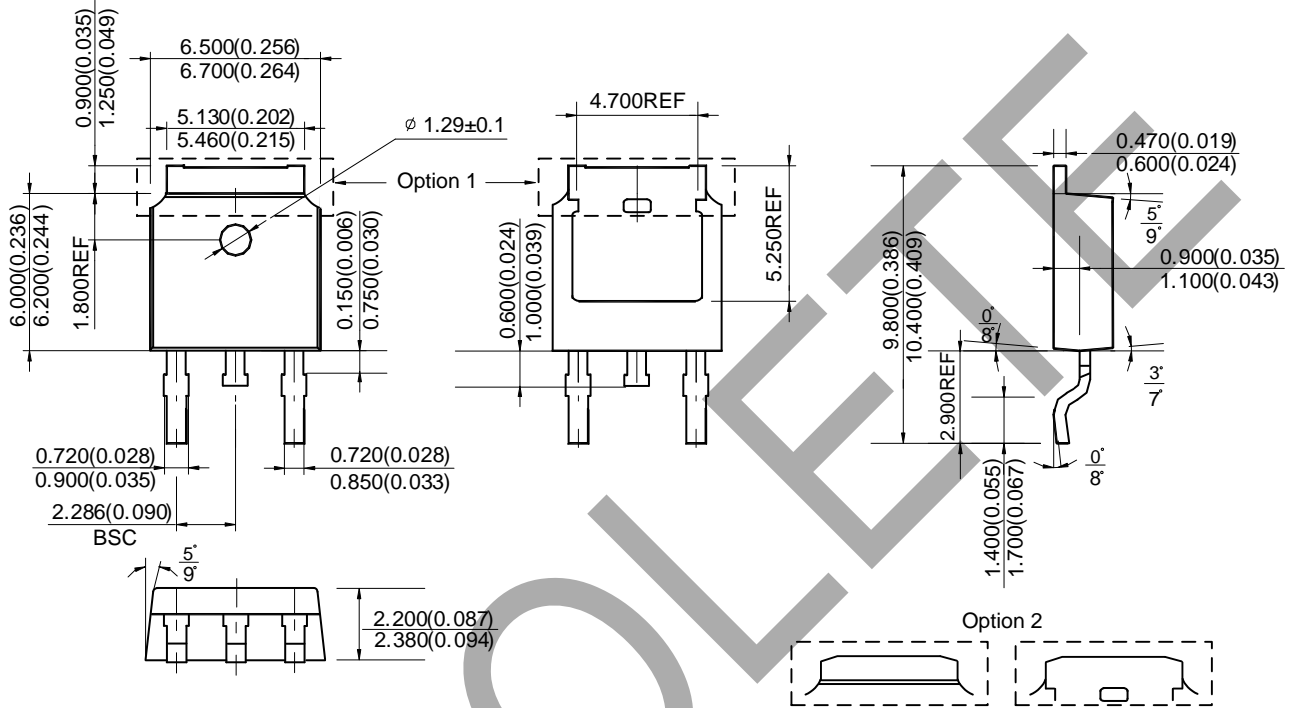

OBSOLETE - PART DISCONTINUED

OBSOLETE

**Package Outline Dimensions** (All dimensions in mm(inch) (continued))

Please see <http://www.diodes.com/package-outlines.html> for the latest version.

**(6) Package Type: TO-252-2 (4)**

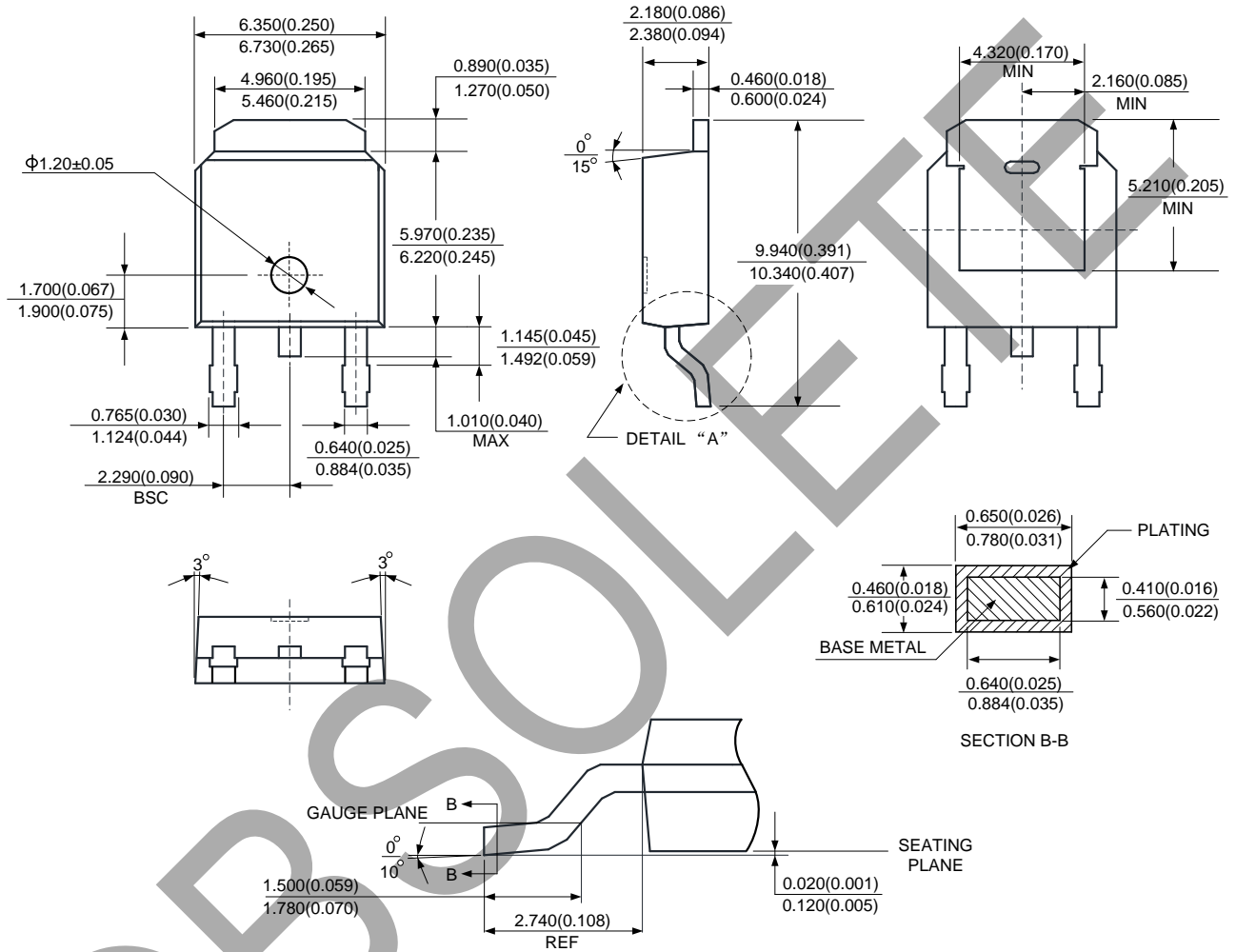

OBSOLETE - PART DISCONTINUED

**IMPORTANT NOTICE**

DIODES INCORPORATED MAKES NO WARRANTY OF ANY KIND, EXPRESS OR IMPLIED, WITH REGARDS TO THIS DOCUMENT, INCLUDING, BUT NOT LIMITED TO, THE IMPLIED WARRANTIES OF MERCHANTABILITY AND FITNESS FOR A PARTICULAR PURPOSE (AND THEIR EQUIVALENTS UNDER THE LAWS OF ANY JURISDICTION).

Diodes Incorporated and its subsidiaries reserve the right to make modifications, enhancements, improvements, corrections or other changes without further notice to this document and any product described herein. Diodes Incorporated does not assume any liability arising out of the application or use of this document or any product described herein; neither does Diodes Incorporated convey any license under its patent or trademark rights, nor the rights of others. Any Customer or user of this document or products described herein in such applications shall assume all risks of such use and will agree to hold Diodes Incorporated and all the companies whose products are represented on Diodes Incorporated website, harmless against all damages.

Diodes Incorporated does not warrant or accept any liability whatsoever in respect of any products purchased through unauthorized sales channel. Should Customers purchase or use Diodes Incorporated products for any unintended or unauthorized application, Customers shall indemnify and hold Diodes Incorporated and its representatives harmless against all claims, damages, expenses, and attorney fees arising out of, directly or indirectly, any claim of personal injury or death associated with such unintended or unauthorized application.

Products described herein may be covered by one or more United States, international or foreign patents pending. Product names and markings noted herein may also be covered by one or more United States, international or foreign trademarks.

This document is written in English but may be translated into multiple languages for reference. Only the English version of this document is the final and determinative format released by Diodes Incorporated.

**LIFE SUPPORT**

Diodes Incorporated products are specifically not authorized for use as critical components in life support devices or systems without the express written approval of the Chief Executive Officer of Diodes Incorporated. As used herein:

- A. Life support devices or systems are devices or systems which:
1. are intended to implant into the body, or
  2. support or sustain life and whose failure to perform when properly used in accordance with instructions for use provided in the labeling can be reasonably expected to result in significant injury to the user.
- B. A critical component is any component in a life support device or system whose failure to perform can be reasonably expected to cause the failure of the life support device or to affect its safety or effectiveness.

Customers represent that they have all necessary expertise in the safety and regulatory ramifications of their life support devices or systems, and acknowledge and agree that they are solely responsible for all legal, regulatory and safety-related requirements concerning their products and any use of Diodes Incorporated products in such safety-critical, life support devices or systems, notwithstanding any devices- or systems-related information or support that may be provided by Diodes Incorporated. Further, Customers must fully indemnify Diodes Incorporated and its representatives against any damages arising out of the use of Diodes Incorporated products in such safety-critical, life support devices or systems.

Copyright © 2020, Diodes Incorporated

[www.diodes.com](http://www.diodes.com)