

OBSOLETE - PART DISCONTINUED

Description

The DGD23892 is a three-phase gate driver IC designed for high-voltage / high-speed applications, driving N-Channel MOSFETs and IGBTs in a half-bridge configuration. High-voltage processing techniques enable the DGD23892's high-side to switch to 600V in a bootstrap operation.

The DGD23892 logic inputs are compatible with standard TTL and CMOS levels (down to 3.3V) for easy interfacing with controlling devices and are enabled low to better function in high-noise environments. The driver outputs feature high-pulse current buffers designed for minimum driver cross conduction.

The DGD23892 offers numerous protection functions. A shoot-through protection logic prevents both outputs from being high when both inputs are high (fault state), an undervoltage lockout (UVLO) for V_{CC} shuts down all drivers through an internal fault control, and a UVLO for VBS shuts down the respective high side output. An overcurrent protection will terminate the six outputs. Both the V_{CC} UVLO and the overcurrent protection trip an automatic fault clear with a timing that is adjustable with an external capacitor.

The DGD23892 is offered in SO-28 (Type TH) package and the operating temperature extends from -40°C to $+125^{\circ}\text{C}$.

Applications

- 3-Phase Motor Inverter Driver
- White Goods – Air Conditioner, Washing Machine, Refrigerator
- Industrial Motor Inverter – Power Tools, Robotics
- General Purpose 3-Phase Inverter

Features

- Three Floating High-Side Drivers in Bootstrap Operation to 600V
- 350mA Source / 650mA Sink Output Current Capability
- Outputs Tolerant to Negative Transients, dV/dt Immune
- Logic Input 3.3V Capability
- Internal Deadtime of 290ns to Protect MOSFETs
- Matched Prop Delay for All Channels
- Outputs Out of Phase with Inputs
- Schmitt Triggered Logic Inputs
- Cross Conduction Prevention Logic
- Undervoltage Lockout for All Channels
- Overcurrent Protection Shuts Down Drivers
- Extended Temperature Range: -40°C to $+125^{\circ}\text{C}$
- **Totally Lead-Free & Fully RoHS Compliant (Notes 1 & 2)**
- **Halogen and Antimony Free. "Green" Device (Note 3)**
- **For automotive applications requiring specific change control (i.e. parts qualified to AEC-Q100/101/200, PPAP capable, and manufactured in IATF 16949 certified facilities), please [contact us](#) or your local Diodes representative.**
<https://www.diodes.com/quality/product-definitions/>

Mechanical Data

- Case: SO-28
- Case Material: Molded Plastic. "Green" Molding Compound.
- UL Flammability Classification Rating 94V-0
- Moisture Sensitivity: Level 3 per J-STD-020
- Terminals: Finish – Matte Tin Plated Leads, Solderable per MIL-STD-202, Method 208 (e3)
- Weight: 0.250 grams (Approximate)

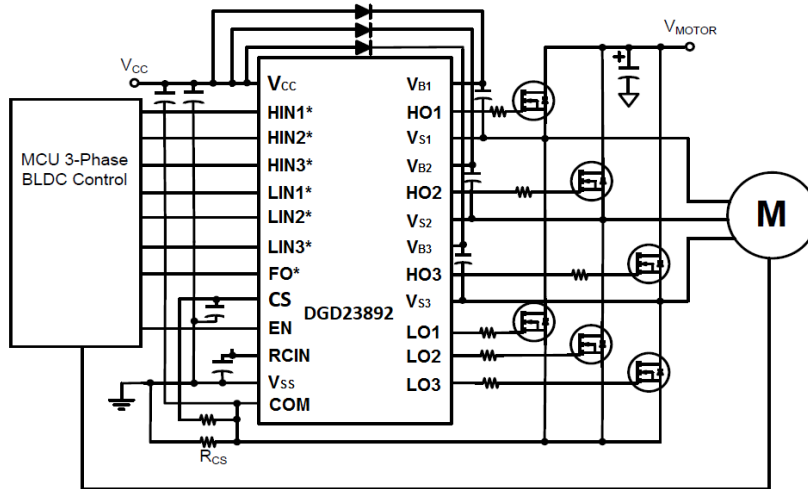

Typical Configuration

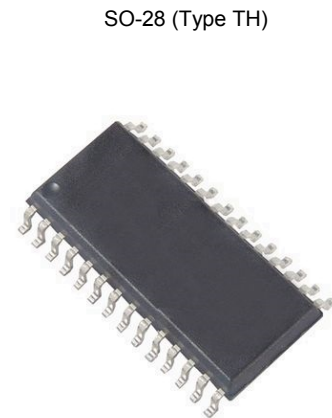

SO-28 (Type TH)

Top View

Ordering Information (Note 4)

Part Number	Marking	Reel Size (inches)	Tape Width (mm)	Quantity per Reel
DGD23892S28-13	DGD23892	13	24	1,500

- Notes:
1. No purposely added lead. Fully EU Directive 2002/95/EC (RoHS), 2011/65/EU (RoHS 2) & 2015/863/EU (RoHS 3) compliant.
 2. See <https://www.diodes.com/quality/lead-free/> for more information about Diodes Incorporated's definitions of Halogen- and Antimony-free, "Green" and Lead-free.
 3. Halogen- and Antimony-free "Green" products are defined as those which contain <900ppm bromine, <900ppm chlorine (<1500ppm total Br + Cl) and <1000ppm antimony compounds.
 4. For packaging details, go to our website at <https://www.diodes.com/design/support/packaging/diodes-packaging/>.

OBSOLETE - PART DISCONTINUED

Marking Information

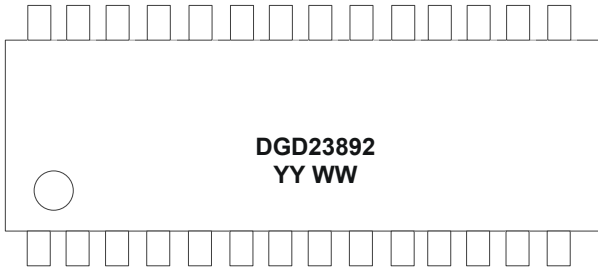

J; ; = Manufacturer's Marking
 DGD23892 = Product Type Marking Code
 YY = Year (ex: 20 = 2020)
 WW = Week (01 to 53)

Pin Diagrams

Top View

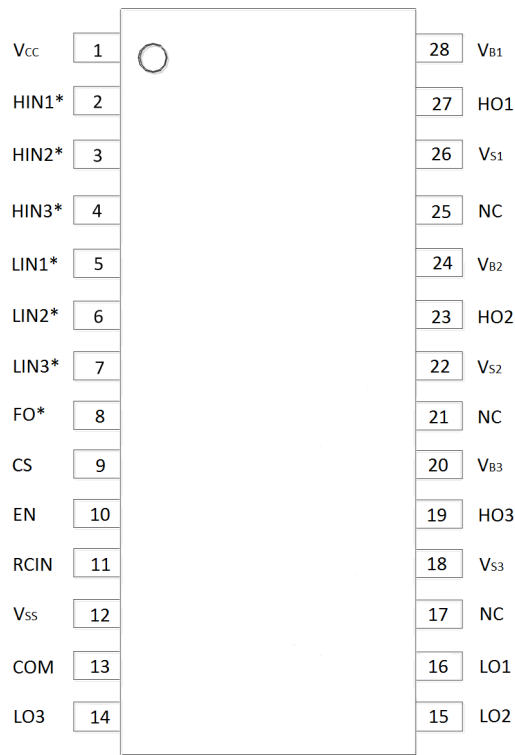

SO-28 (Type TH)

OBSOLETE - PART DISCONTINUED

Pin Descriptions

Pin Number	Pin Name	Function
1	V _{CC}	Low-Side and Logic Fixed Supply
2,3,4	HIN1*,HIN2*,HIN3*	Logic Input for High-Side Gate Driver Output, Out of Phase with HO
5,6,7	LIN1*,LIN2*,LIN3*	Logic Input for Low-Side Gate Driver Output, Out of Phase with LO
8	FO*	Fault Output with Open Drain (Fault with Overcurrent and V _{CC} UVLO)
9	CS	Analog Input for Overcurrent Shutdown
10	EN	Logic Input for Functionality, I/O Logic Functions when EN is High
11	RCIN	An External RC Network Input used to Define FAULT CLEAR Delay
12	V _{SS}	Logic Ground
13	COM	Low-Side Driver Return
14,15,16	LO3,LO2,LO1	Low-Side Gate Driver Output
17,21,25	NC	No Connection (No Internal Connection)
18,22,26	V _{S3} , V _{S2} , V _{S1}	High-Side Floating Supply Return
19,23,27	HO3,HO2,HO1	High-Side Gate Driver Output
20,24,28	V _{B3} , V _{B2} , V _{B1}	High-Side Floating Supply

Functional Block Diagram

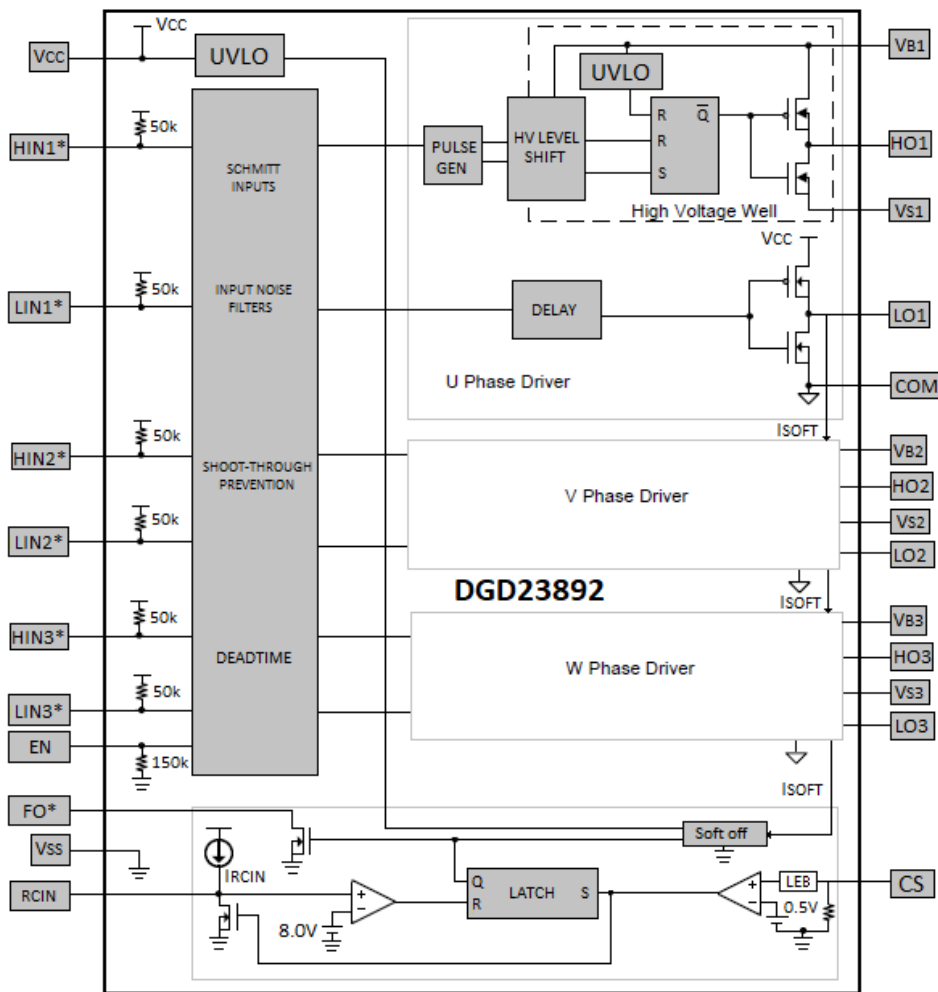

Absolute Maximum Ratings (@ $T_A = +25^\circ\text{C}$, unless otherwise specified.)

Characteristic	Symbol	Value	Unit
High-Side Floating Supply Voltage	V_B	-0.3 to +618	V
High-Side Floating Supply Offset Voltage	V_S	$V_B - 18$ to $V_B + 0.3$	V
High-Side Floating Output Voltage	V_{HO}	$V_S - 0.3$ to $V_B + 0.3$	V
Low-Side Output Voltage	V_{LO}	-0.3 to $V_{CC} + 0.3$	V
Offset Supply Voltage Transient	dV_S / dt	50	V/ns
Low-Side Fixed Supply Voltage	V_{CC}	-0.3 to +18	V
Logic Input Voltage (HIN*, LIN*, CS, EN and FO*)	V_{IN}	-0.3 to +5.5	V

Thermal Characteristics (@ $T_A = +25^\circ\text{C}$, unless otherwise specified.)

Characteristic	Symbol	Value	Unit
Power Dissipation Linear Derating Factor (Note 5)	P_D	2.3	W
Thermal Resistance, Junction to Ambient (Note 5)	$R_{\theta JA}$	60	$^\circ\text{C/W}$
Thermal Resistance, Junction to Case (Note 5)	$R_{\theta JC}$	45	$^\circ\text{C/W}$
Operating Temperature	T_J	+150	$^\circ\text{C}$
Lead Temperature (Soldering, 10s)	T_L	+300	
Storage Temperature Range	T_{STG}	-55 to +150	

Note: 5. When mounted on a standard JEDEC 2-layer FR-4 board.

Recommended Operating Conditions

Parameter	Symbol	Min	Max	Unit
High-Side Floating Supply Absolute Voltage	V_B	$V_S + 10$	$V_S + 15$	V
High-Side Floating Supply Offset Voltage	V_S	(Note 6)	600	V
High-Side Floating Output Voltage	V_{HO}	V_S	V_B	V
Low-Side Fixed Supply Voltage	V_{CC}	10	15	V
Low-Side Output Voltage	V_{LO}	COM	V_{CC}	V
Logic Input Voltage (HIN*, LIN*, CS & EN)	V_{IN}	V_{SS}	5	V
Fault Output Voltage	V_{FO}	V_{SS}	V_{CC}	V
Logic Ground	V_{SS}	-5	5	V
Ambient Temperature	T_A	-40	+125	$^\circ\text{C}$

Note: 6. Logic operation for V_S of -5V to +600V.

DC Electrical Characteristics (V_{BIAS} (V_{CC} , V_{BS}) = 15V, @ T_A = +25°C, unless otherwise specified.) (Note 7)

Parameter	Symbol	Min	Typ	Max	Unit	Condition
Logic "0" Input Voltage	V_{IH}	2.4	—	—	V	—
Logic "1" Input Voltage	V_{IL}	—	—	0.8	V	—
High Level Output Voltage, $V_{BIAS} - V_O$	V_{OH}	—	—	0.1	V	$I_O = 0mA$
Low Level Output Voltage, V_O	V_{OL}	—	—	0.1	V	$I_O = 0mA$
Offset Supply Leakage Current	I_{LK}	—	—	10	μA	$V_B = V_S = 600V$
Quiescent V_{BS} Supply Current	I_{BSQ}	10	85	130	μA	$V_{IN} = 0V$ or $5V$, $EN = 0V$
Quiescent V_{CC} Supply Current	I_{CCQ}	—	1.1	1.6	mA	$V_{IN} = 0V$ or $5V$, $EN = 0V$
Logic Input Bias Current (HO=LO=HIGH)	I_{IN+}	—	130	200	μA	$V_{IN} = 0V$
Logic Input Bias Current (HO=LO=LOW)	I_{IN-}	—	3.0	20	μA	$V_{IN} = 5V$
Logic Enable "1" Input Bias Current	I_{EN+}	—	50	80	μA	$V_{EN} = 5V$
Logic Enable "0" Input Bias Current	I_{EN-}	—	—	2.0	μA	$V_{EN} = 0V$
V_{BS} Supply Undervoltage Positive Going Threshold	V_{BSUV+}	7.6	8.9	9.9	V	—
V_{BS} Supply Undervoltage Negative Going Threshold	V_{BSUV-}	7.1	8.3	9.4	V	—
V_{CC} Supply Undervoltage Positive Going Threshold	V_{CCUV+}	7.6	8.9	9.9	V	—
V_{CC} Supply Undervoltage Negative Going Threshold	V_{CCUV-}	7.1	8.3	9.4	V	—
Output High Short Circuit Pulsed Current	I_{O+}	250	350	—	mA	$V_O = 0V$, $PW \leq 10\mu s$
Output Low Short Circuit Pulsed Current	I_{O-}	500	650	—	mA	$V_O = 15V$, $PW \leq 10\mu s$
Overcurrent Detect Positive Threshold	V_{ITH+}	400	500	600	mV	—
Overcurrent Detect Negative Threshold	V_{ITH-}	340	420	500	mV	—
Short-Circuit Input Current	I_{CSIN}	5.0	15	20	μA	$V_{CSIN} = 1V$
RCIN Internal Current Source	I_{RSIN}	6.0	8.0	10	μA	—
RCIN Positive Going Threshold Voltage	$V_{RCINTH+}$	—	8.0	—	V	—
RCIN Negative Going Threshold Voltage (Note 8)	$V_{RCINTH-}$	—	5.0	—	V	—
Fault Output Low Level Voltage	V_{FOL}	—	0.2	0.5	V	$V_{CS} = 1V$, $I_{FO} = 1.5mA$
RCIN on Resistance	R_{DSRCIN}	40	75	110	Ω	$I_{RCIN} = 1.5mA$
Fault Output on Resistance	R_{DSFO}	80	130	180	Ω	$I_{FO} = 1.5mA$

- Notes: 7. The V_{IN} , V_{TH} and I_{IN} parameters are referenced to V_{SS} and are applicable to all six channels (HIN1*, 2*, 3* and LIN1*, 2*, 3*). The V_O and I_O parameters are applicable to the output pins (HO1, 2, 3 and LO1, 2, 3) and are referenced to COM.
8. Guaranteed by design.

AC Electrical Characteristics (V_{BIAS} (V_{CC} , V_{BS}) = 15V, $C_L = 1000pF$, @ T_A = +25°C, unless otherwise specified.)

Parameter	Symbol	Min	Typ	Max	Unit	Condition
Turn-On Propagation Delay	t_{ON}	200	270	460	ns	$V_S = 0V$
Turn-Off Propagation Delay	t_{OFF}	200	270	460	ns	$V_S = 0V$
Turn-On Rise Time	t_R	—	40	150	ns	$V_S = 0V$
Turn-Off Fall Time	t_F	—	25	60	ns	$V_S = 0V$
Delay Matching	t_{DM}	—	—	50	ns	—
Enable Low to Output Shutdown Delay	t_{EN}	225	260	425	ns	—
CS Pin Leading-Edge Blanking Time (Note 9)	t_{BLT}	200	300	400	ns	—
Time from CS Triggering to FO*	t_{FLT}	360	550	760	ns	From $V_{CS} = 1V$ to FO* turn off
Time from CS Triggering to All Gate Outputs Turn Off	t_{TRIP}	420	615	820	ns	From $V_{CS} = 1V$ to starting gate turn off
Input Filtering Time (HIN*, LIN*, EN)	t_{FLTIN}	—	250	—	ns	—
Fault Clear Time (Note 8)	t_{FLTCLR}	—	3.1	—	ms	$C_{RCIN} = 2nF$
Deadtime	t_{DT}	200	290	420	ns	—
Deadtime Matching	t_{DTM}	—	—	50	ns	—
Output Pulse Width Matching (Note 10)	t_{PM}	—	50	75	ns	$PW_{IN} > 1\mu s$

- Notes: 9. For best performance of CS and FO* in the application, the CS pulse width should be greater than 1.2 μs .
10. t_{PM} is defined as $PW_{IN} - PW_{OUT}$.

OBSOLETE - PART DISCONTINUED

Timing Waveforms

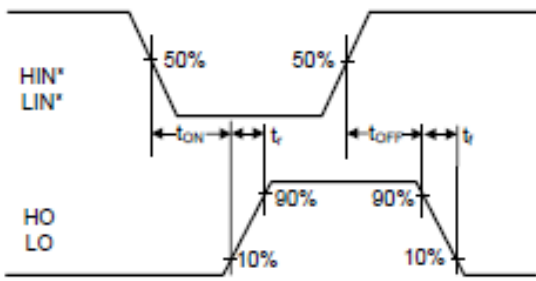

Figure 1. Switching Time Waveform Definitions

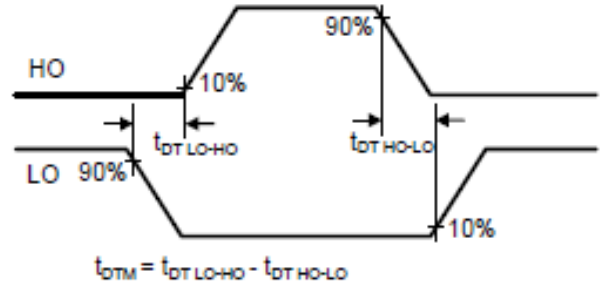

Figure 2. Deadtime Waveform Definitions

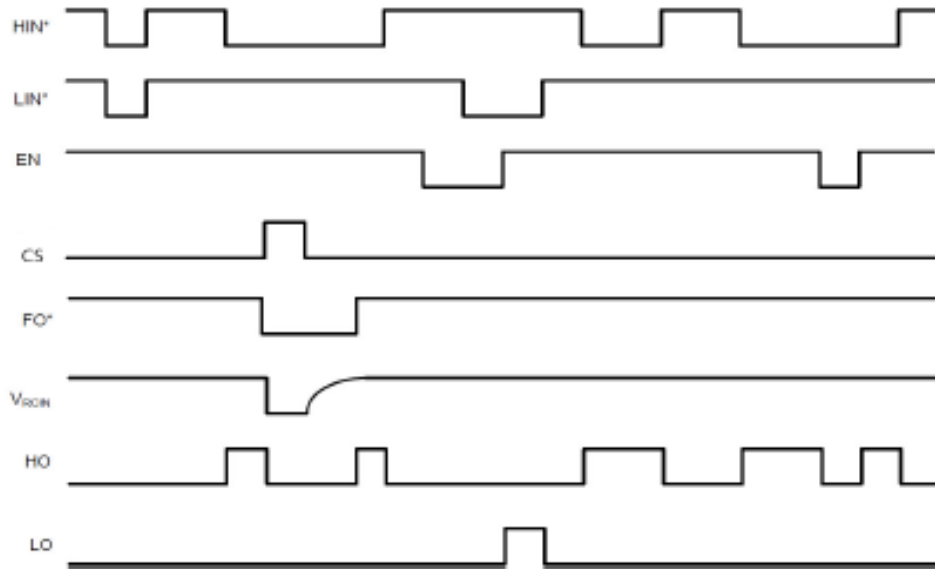

Figure 3. Input/Output Timing Diagram

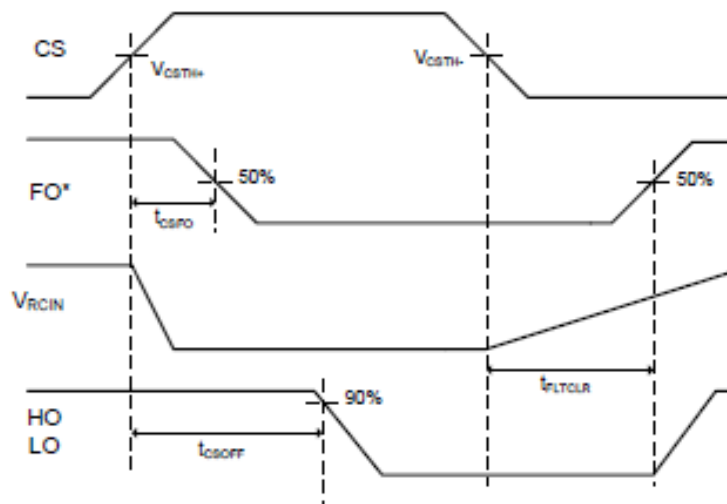

Figure 4. Overcurrent Timing Definitions

Typical Performance Characteristics (@T_A = +25°C, unless otherwise specified.)

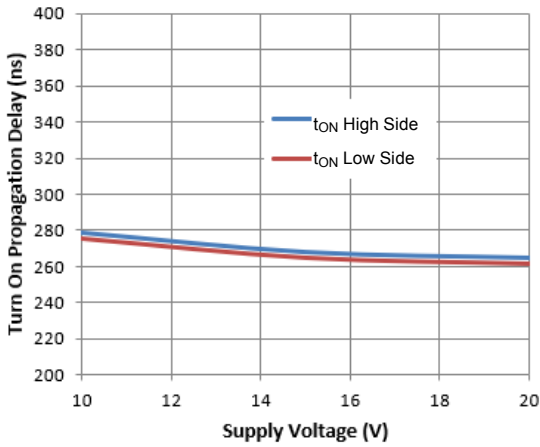

Figure 5. Turn-on Propagation Delay vs. Supply Voltage

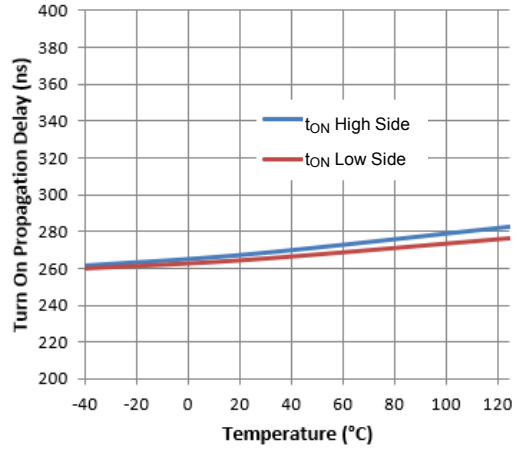

Figure 6. Turn-on Propagation Delay vs. Temperature

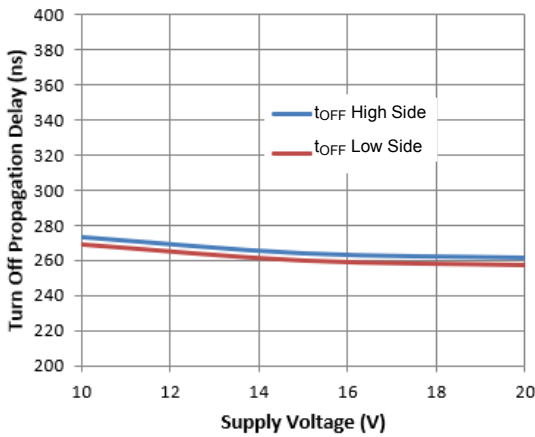

Figure 7. Turn-off Propagation Delay vs. Supply Voltage

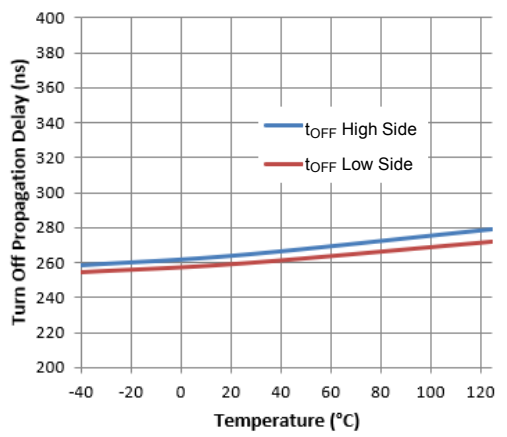

Figure 8. Turn-off Propagation Delay vs. Temperature

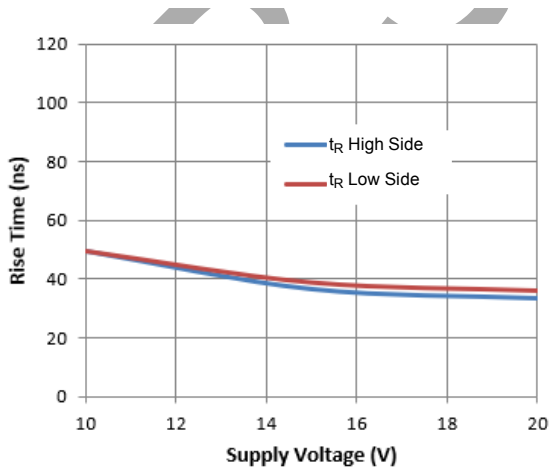

Figure 9. Rise Time vs. Supply Voltage

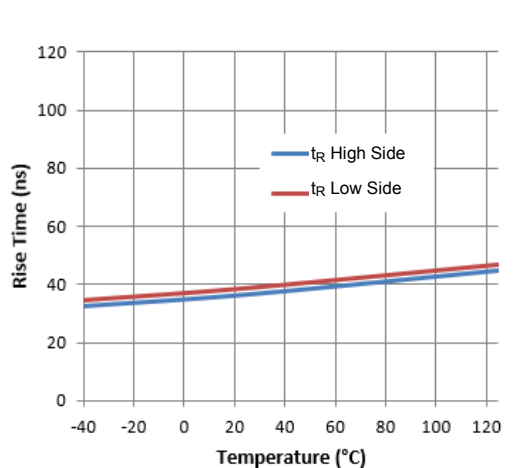

Figure 10. Rise Time vs. Temperature

OBSOLETE – PART DISCONTINUED

Typical Performance Characteristics (continued)

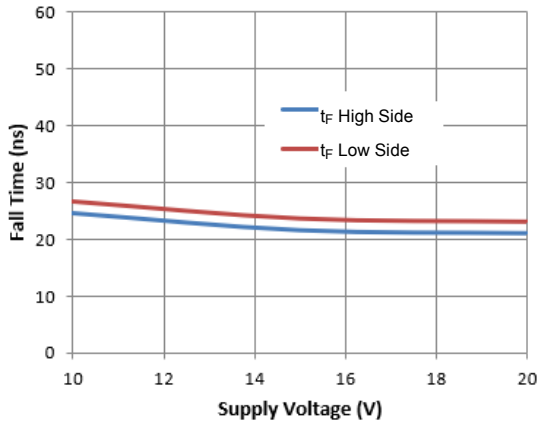

Figure 11. Fall Time vs. Supply Voltage

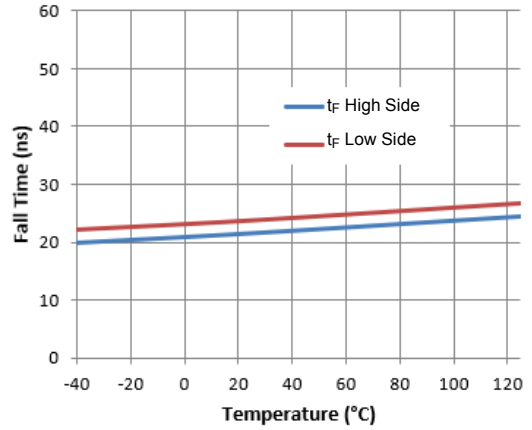

Figure 12. Fall Time vs. Temperature

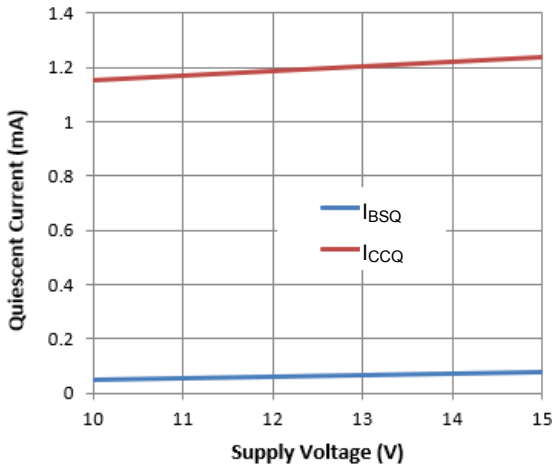

Figure 13. Quiescent Current vs. Supply Voltage

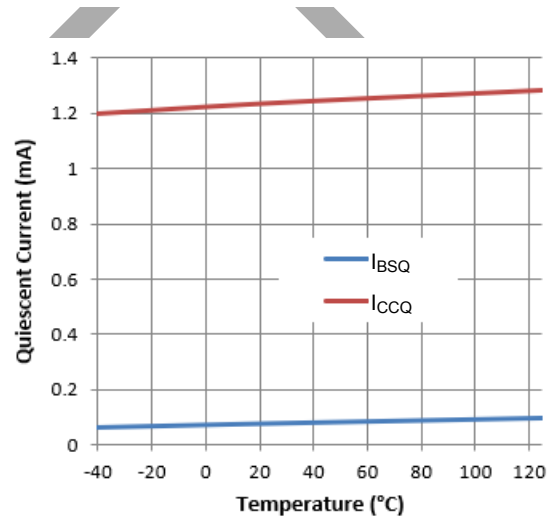

Figure 14. Quiescent Current vs. Temperature

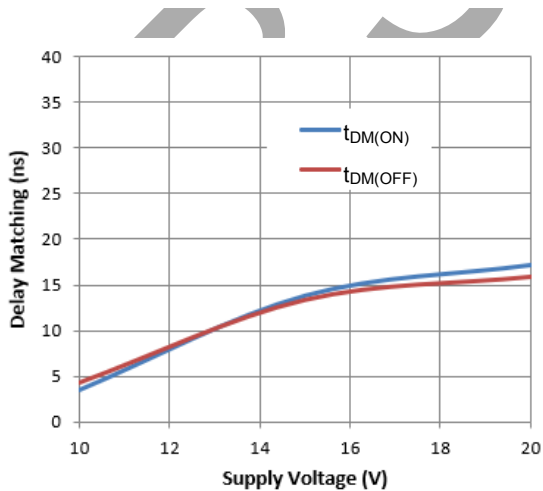

Figure 15. Delay Matching vs. Supply Voltage

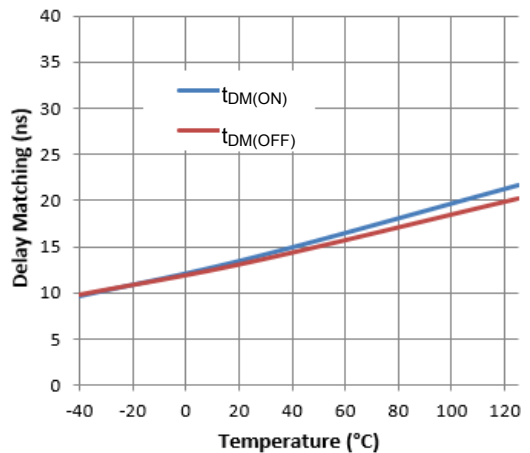

Figure 16. Delay Matching vs. Temperature

OBSOLETE – PART DISCONTINUED

Typical Performance Characteristics (continued)

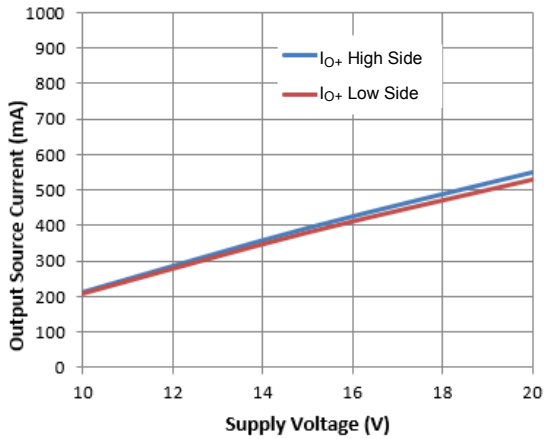

Figure 17. Output Source Current vs. Supply Voltage

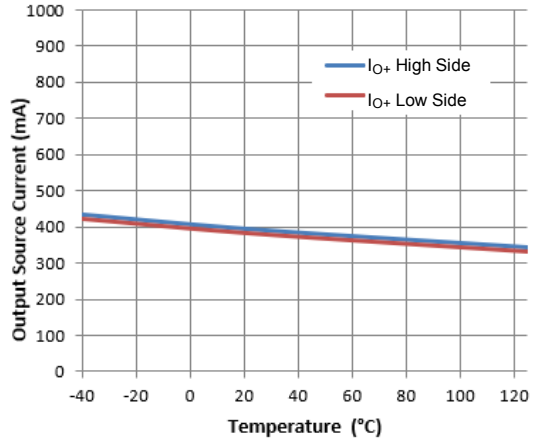

Figure 18. Output Source Current vs. Temperature

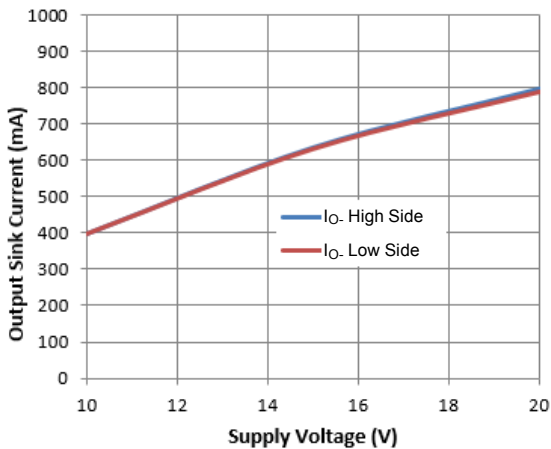

Figure 19. Output Sink Current vs. Supply Voltage

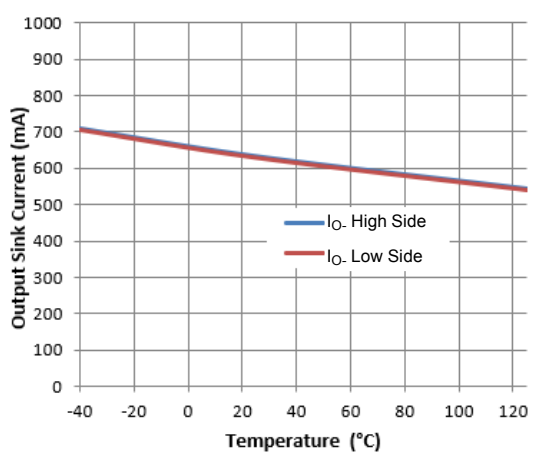

Figure 20. Output Sink Current vs. Temperature

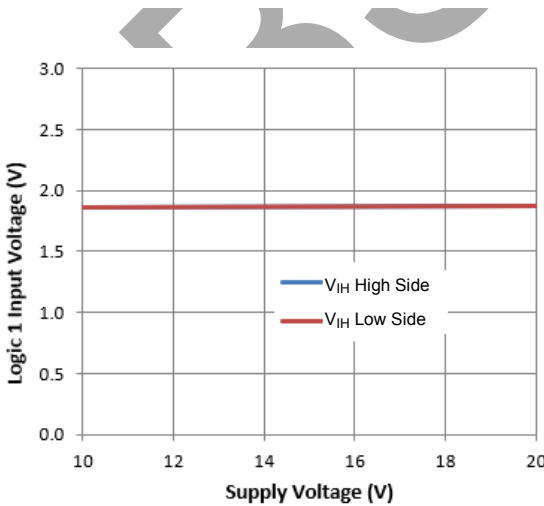

Figure 21. Logic 1 Input Voltage vs. Supply Voltage

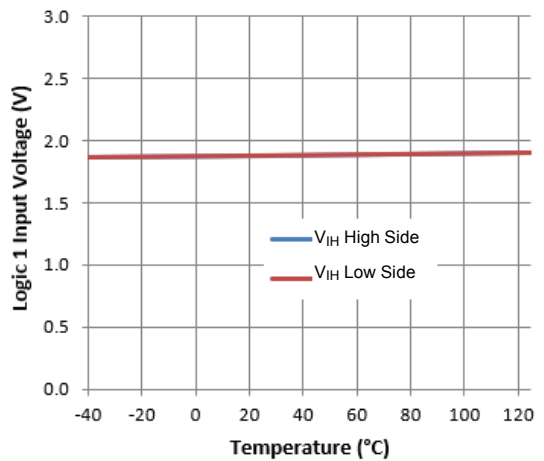

Figure 22. Logic 1 Input Voltage vs. Temperature

OBSOLETE – PART DISCONTINUED

Typical Performance Characteristics (continued)

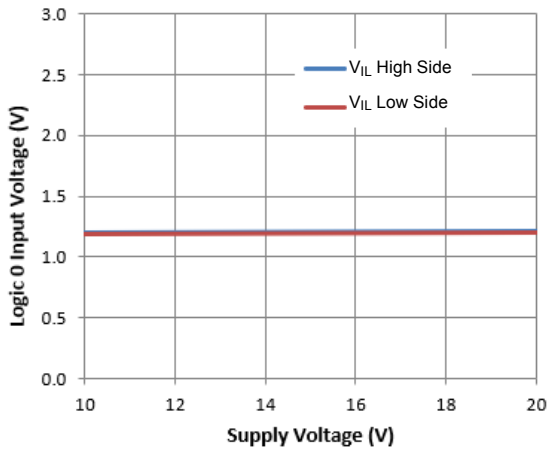

Figure 23. Logic 0 Input Voltage vs. Supply Voltage

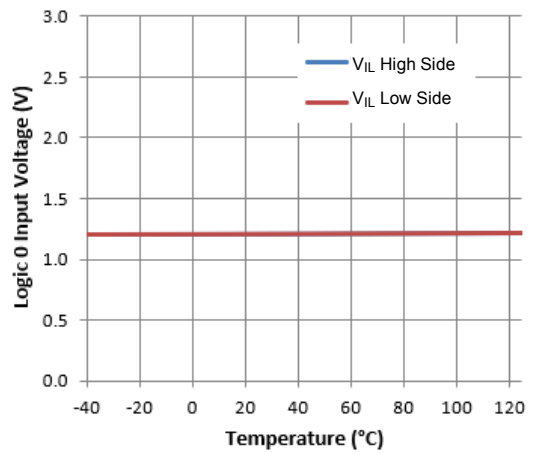

Figure 24. Logic 0 Input Voltage vs. Temperature

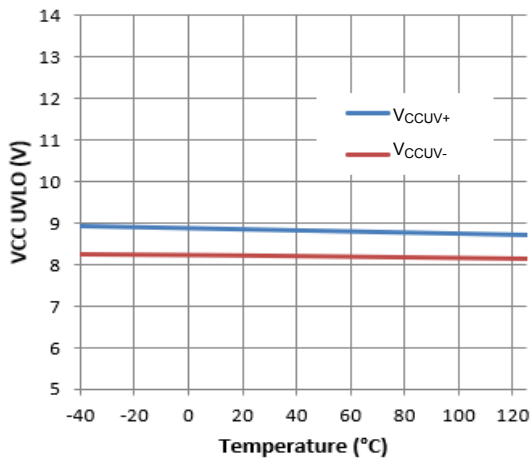

Figure 25. VCC UVLO vs. Temperature

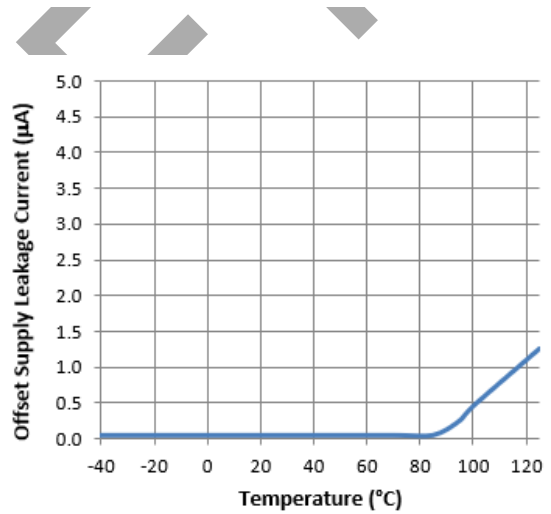

Figure 26. Offset Supply Leakage Current vs. Temperature

OBSOLETE

Design Notes

Over the past decade, in white goods, there has been a transition from AC motors to brushless DC motors; correspondingly power switching is required to drive the BLDC motors. For even greater efficiency and cost reduction, 3-phase gate driver ICs are used to optimally drive MOSFETs and IGBTs. The DGD23892, 3-Phase Half-Bridge Gate Driver IC, is a good choice for 3-phase motor applications because of ease of design, reliability, and less space used than 3 x single channel gate driver ICs.

In the inductive 3-phase motor circuit environment, MOSFET/IGBT turn on produces significant current spikes; and the currents are highest and the system is noisiest during startup. In certain applications, with significant noise on the ground lines of V_{SS} -COM (for example during startup), the DGD23892 is susceptible to the noise and can enter fault condition. And if the fault is long enough, the MCU will detect the fault situation, disable inputs and turn off the system. In effect there is a stall at startup. Figure 27 and Figure 28 show startup in a 240V refrigerator compressor application (FO+MCU (blue) - fault signal at MCU, COM- V_{SS} (yellow) and VS (green) - motor voltage).

This Design Tip will provide two solutions, depending on the current sense circuit, to decrease the IC ground noise and ensure the DGD23892 does not enter fault condition and there is no stall at startup.

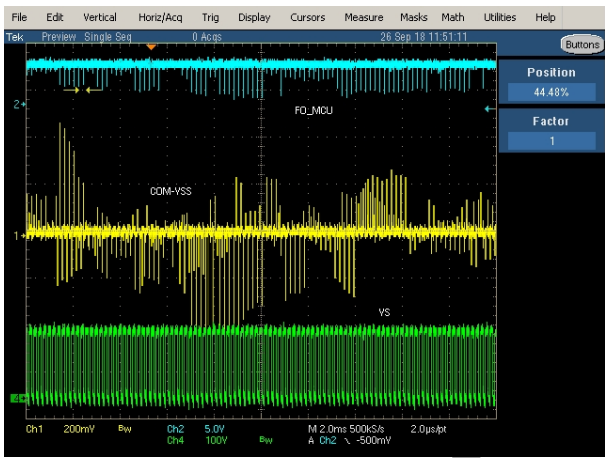

Figure 27. During startup when the current is high, COM- V_{SS} noise is high (yellow), fault conditions occur (blue), compressor will eventually stall, 2ms/div

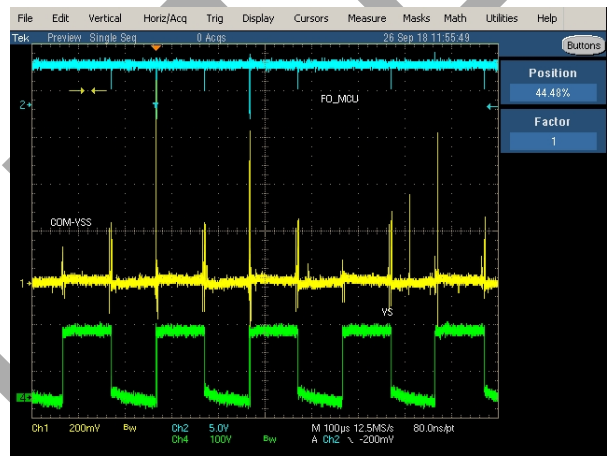

Figure 28. During startup, current is high, COM- V_{SS} noise is high, fault conditions occur, compressor will eventually stall, 100µs/div

Solution 1

If the 3 phase current sensing configuration is similar to Figure 29 or Figure 30, then the best solution is to short the line between V_{SS} and COM directly at the IC. This provides a more stable ground at the IC, and the current sense circuit operates normally (see Figures 31 and 32).

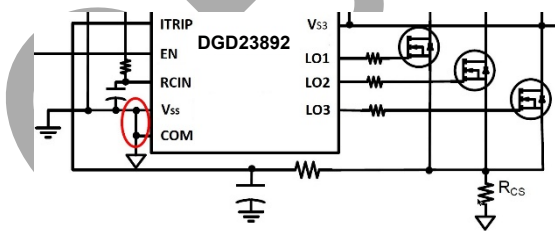

Figure 29. Shorting V_{SS} -COM at IC for current sense configuration A

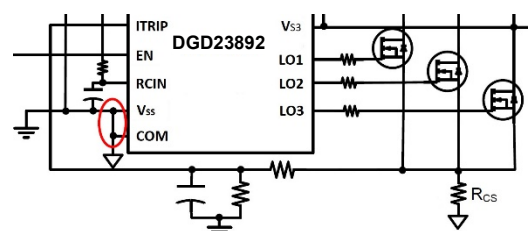

Figure 30. Shorting V_{SS} -COM at IC for current sense configuration B

Design Notes (continued)

OBSOLETE - PART DISCONTINUED

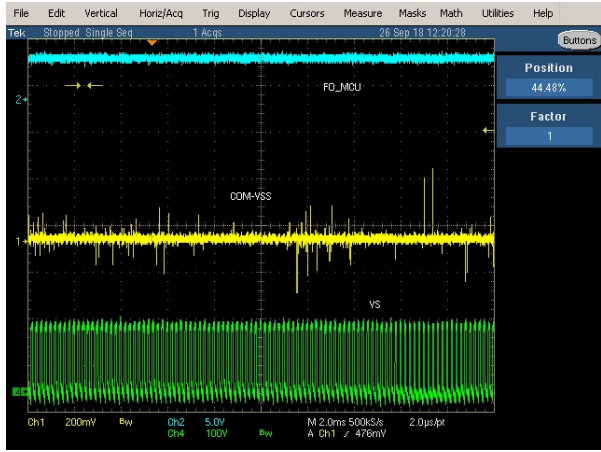

Figure 31. During startup, current is high, with shorted COM-V_{SS}, noise is less, fault conditions do not occur, compressor will not stall, 2ms/div

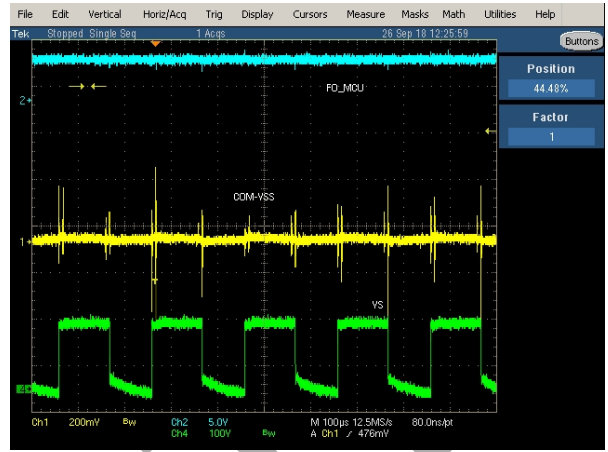

Figure 32. During startup, current is high, with shorted COM-V_{SS}, noise is less, fault conditions do not occur, compressor will not stall, 100µs/div

Solution 2

If the 3-phase current sensing configuration is similar to Figure 33, then the best solution is to add a ceramic capacitor (0.022 - 0.1µF) between V_{SS} and COM directly at the IC. This provides a more stable ground at the IC, and the current sense circuit operates normally (see Figures 34 and 35).

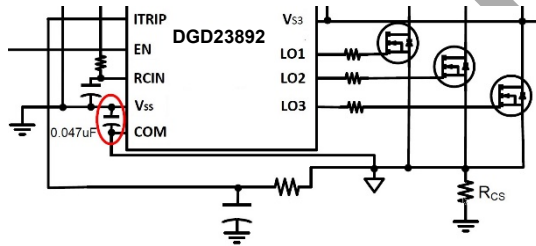

Figure 33. Adding capacitor between V_{SS}-COM at IC for current sense configuration C

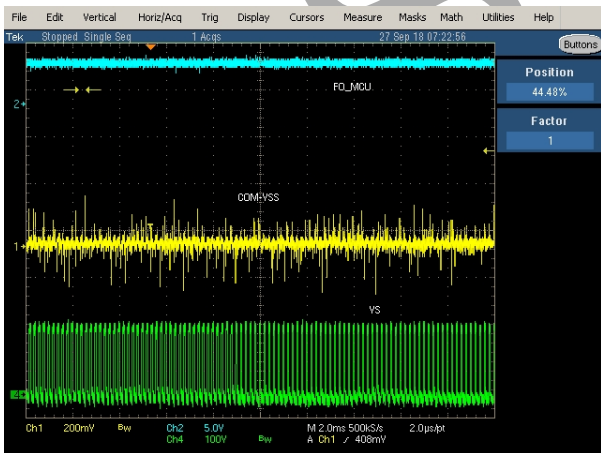

Figure 34. During startup current is high, with cap between COM-V_{SS}, noise is less, fault conditions do not occur, compressor will not stall, 2ms/div

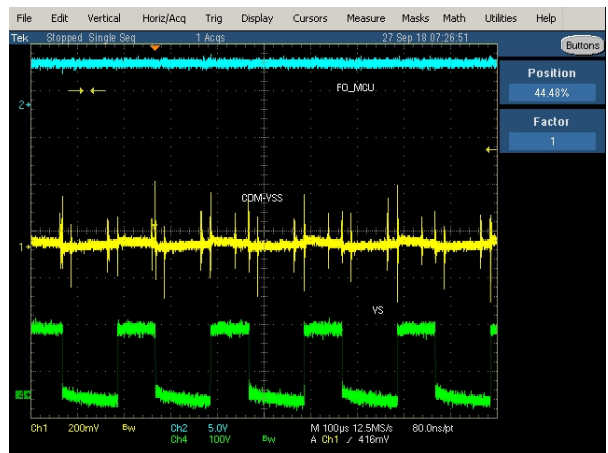

Figure 35. During startup current is high, with cap between COM-V_{SS}, noise is less, fault conditions do not occur, compressor will not stall, 100µs/div

Summary

To improve the performance of the DGD23892 during high current operation of 3-phase motor applications, it is best to make a more stable IC ground. Depending on the current sense circuit arrangement in the 3-phase motor driver application, two solutions are provided: one that shorts the connection between COM-V_{SS} and another is adding a ceramic capacitor between COM-V_{SS}. In a compressor application, there were no fault conditions seen at the MCU and the COM-V_{SS} noise was significantly less with the solutions provided.

OBSOLETE - PART DISCONTINUED

Package Outline Dimensions

Please see <http://www.diodes.com/package-outlines.html> for the latest version.

SO-28 (Type TH)

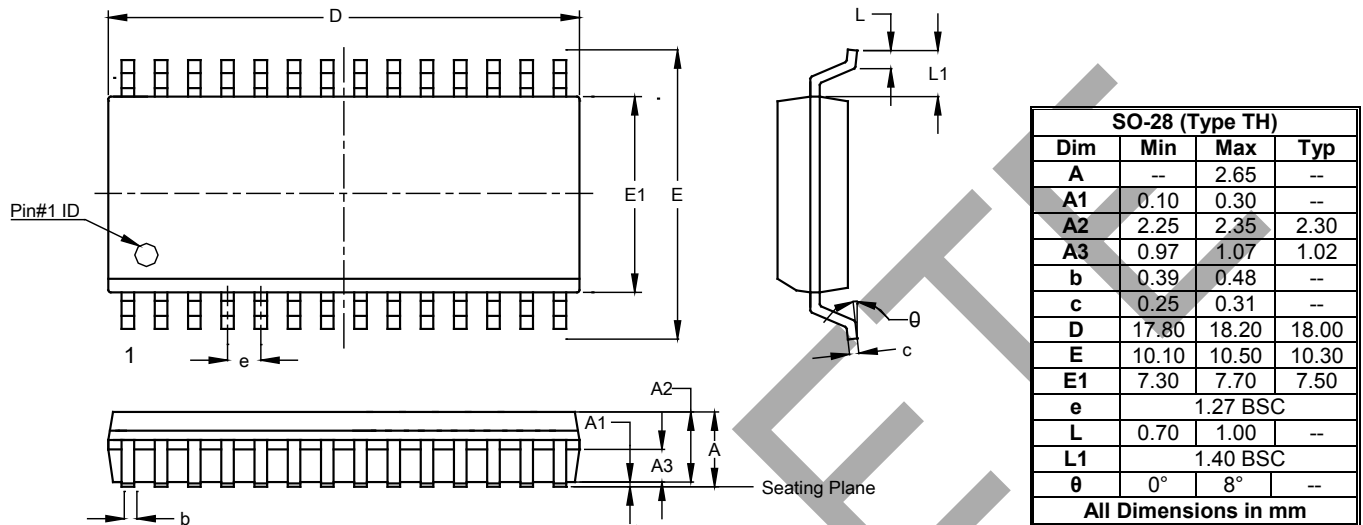

Suggested Pad Layout

Please see <http://www.diodes.com/package-outlines.html> for the latest version.

SO-28 (Type TH)

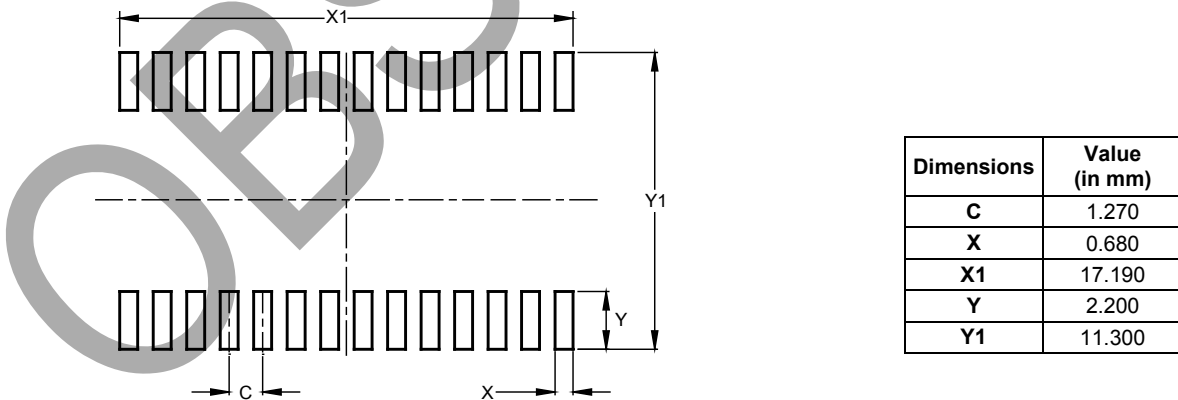

Note: For high voltage applications, the appropriate industry sector guidelines should be considered with regards to creepage and clearance distances between device Terminals and PCB tracking.

IMPORTANT NOTICE

1. DIODES INCORPORATED AND ITS SUBSIDIARIES ("DIODES") MAKE NO WARRANTY OF ANY KIND, EXPRESS OR IMPLIED, WITH REGARDS TO ANY INFORMATION CONTAINED IN THIS DOCUMENT, INCLUDING, BUT NOT LIMITED TO, THE IMPLIED WARRANTIES OF MERCHANTABILITY, FITNESS FOR A PARTICULAR PURPOSE OR NON-INFRINGEMENT OF THIRD PARTY INTELLECTUAL PROPERTY RIGHTS (AND THEIR EQUIVALENTS UNDER THE LAWS OF ANY JURISDICTION).
2. The Information contained herein is for informational purpose only and is provided only to illustrate the operation of Diodes products described herein and application examples. Diodes does not assume any liability arising out of the application or use of this document or any product described herein. This document is intended for skilled and technically trained engineering customers and users who design with Diodes products. Diodes products may be used to facilitate safety-related applications; however, in all instances customers and users are responsible for (a) selecting the appropriate Diodes products for their applications, (b) evaluating the suitability of the Diodes products for their intended applications, (c) ensuring their applications, which incorporate Diodes products, comply the applicable legal and regulatory requirements as well as safety and functional-safety related standards, and (d) ensuring they design with appropriate safeguards (including testing, validation, quality control techniques, redundancy, malfunction prevention, and appropriate treatment for aging degradation) to minimize the risks associated with their applications.
3. Diodes assumes no liability for any application-related information, support, assistance or feedback that may be provided by Diodes from time to time. Any customer or user of this document or products described herein will assume all risks and liabilities associated with such use, and will hold Diodes and all companies whose products are represented herein or on Diodes' websites, harmless against all damages and liabilities.
4. Products described herein may be covered by one or more United States, international or foreign patents and pending patent applications. Product names and markings noted herein may also be covered by one or more United States, international or foreign trademarks and trademark applications. Diodes does not convey any license under any of its intellectual property rights or the rights of any third parties (including third parties whose products and services may be described in this document or on Diodes' website) under this document.
5. Diodes products are provided subject to Diodes' Standard Terms and Conditions of Sale (<https://www.diodes.com/about/company/terms-and-conditions/terms-and-conditions-of-sales/>) or other applicable terms. This document does not alter or expand the applicable warranties provided by Diodes. Diodes does not warrant or accept any liability whatsoever in respect of any products purchased through unauthorized sales channel.
6. Diodes products and technology may not be used for or incorporated into any products or systems whose manufacture, use or sale is prohibited under any applicable laws and regulations. Should customers or users use Diodes products in contravention of any applicable laws or regulations, or for any unintended or unauthorized application, customers and users will (a) be solely responsible for any damages, losses or penalties arising in connection therewith or as a result thereof, and (b) indemnify and hold Diodes and its representatives and agents harmless against any and all claims, damages, expenses, and attorney fees arising out of, directly or indirectly, any claim relating to any noncompliance with the applicable laws and regulations, as well as any unintended or unauthorized application.
7. While efforts have been made to ensure the information contained in this document is accurate, complete and current, it may contain technical inaccuracies, omissions and typographical errors. Diodes does not warrant that information contained in this document is error-free and Diodes is under no obligation to update or otherwise correct this information. Notwithstanding the foregoing, Diodes reserves the right to make modifications, enhancements, improvements, corrections or other changes without further notice to this document and any product described herein. This document is written in English but may be translated into multiple languages for reference. Only the English version of this document is the final and determinative format released by Diodes.
8. Any unauthorized copying, modification, distribution, transmission, display or other use of this document (or any portion hereof) is prohibited. Diodes assumes no responsibility for any losses incurred by the customers or users or any third parties arising from any such unauthorized use.

Copyright © 2021 Diodes Incorporated

www.diodes.com

OBSOLETE - PART DISCONTINUED