

**Automotive 8-Bit Bi-Directional Level Shifter with Automatic Direction Sensing for Push-Pull and Open-Drain Applications**

**Description**

The DIODES LXS0108Q is an automotive, 8-bit, dual-supply, automatic direction sensing level translator. The A and B ports are designed to track two different power supply rails,  $V_{CCA}$  and  $V_{CCB}$  respectively. This allows bi-directional translation between lower and higher logic signals. Each channel can be mixed and matched with different output types (open-drain or push-pull) and mixed data flows (transmit or receive) without intervention from the host.

When the OE pin is low, all I/Os are configured to be in a high-impedance state. To ensure the Hi-Z state during power-up or power-down periods, tie OE to GND through a pull-down resistor. The minimum value of the resistor is determined by the current-sourcing capability of the driver. The LXS0108Q is available in TSSOP-20 package with temperature range specified from  $-40^{\circ}\text{C}$  to  $+125^{\circ}\text{C}$ .

**Block Diagram**

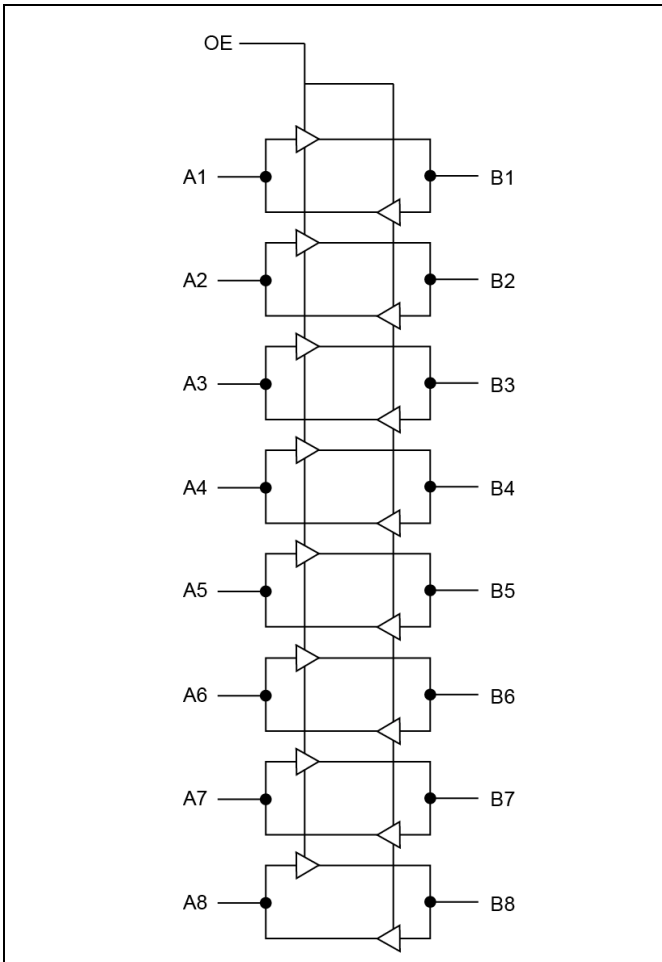

**Figure 1. Block Diagram**

**Notes:**

1. No purposely added lead. Fully EU Directive 2002/95/EC (RoHS), 2011/65/EU (RoHS 2) & 2015/863/EU (RoHS 3) compliant.
2. See <https://www.diodes.com/quality/lead-free/> for more information about Diodes Incorporated's definitions of Halogen- and Antimony-free, "Green" and Lead-free.
3. Halogen- and Antimony-free "Green" products are defined as those which contain <900ppm bromine, <900ppm chlorine (<1500ppm total Br + Cl) and <1000ppm antimony compounds.

**Features**

- AEC-Q100 Grade 1
- Specified From  $-40^{\circ}\text{C}$  to  $+125^{\circ}\text{C}$
- 3.3V and 5.0V Translations
  - 110Mbps (Push-Pull)
  - 0.8Mbps (Open-Drain)
- 1.8V and 2.5V, 3.3V, 5.0V Translations
  - 50Mbps (Push-Pull)
  - 0.8Mbps (Open-Drain)
- 1.2V and 1.8V, 2.5V, 3.3V, 5.0V Translations
  - 20Mbps (Push-Pull)
  - 0.6Mbps (Open-Drain)
- $V_{CCA}$ : 1.2V to 3.6V
- $V_{CCB}$ : 1.65V to 5.5V
- $V_{CCA}$  Must Be Less Than or Equal to  $V_{CCB}$
- No Direction-Control Signal Required
- Bit-to-Bit Skew as Low as 1.0ns
- ESD Protection Per ANSI/ESDA/JEDEC JS-001
  - A Port: HBM  $\pm 5000\text{V}$
  - B Port: HBM  $\pm 8000\text{V}$
- IEC 61000-4-2 ESD (B Port)
  - $\pm 8000\text{V}$  Contact Discharge
- Integrated Pull-Up Resistors
- Totally Lead-Free & Fully RoHS Compliant (Notes 1 & 2)
- Halogen and Antimony Free. "Green" Device (Note 3)
- The LXS0108Q is suitable for automotive applications requiring specific change control; the part is AEC-Q100 qualified, PPAP capable, and manufactured in IATF 16949 certified facilities.  
<https://www.diodes.com/quality/product-definitions/>
- Packaging (Pb-free & Green):
  - 20-pin, TSSOP (L)

**Application(s)**

- GPIO, SPI, SDIO, UART
- I2C or 1-Wire Voltage-Level Translation
- Infotainments and Digital Clusters
- Automotive ADAS
- Automotive Telematics

## Pin Configuration

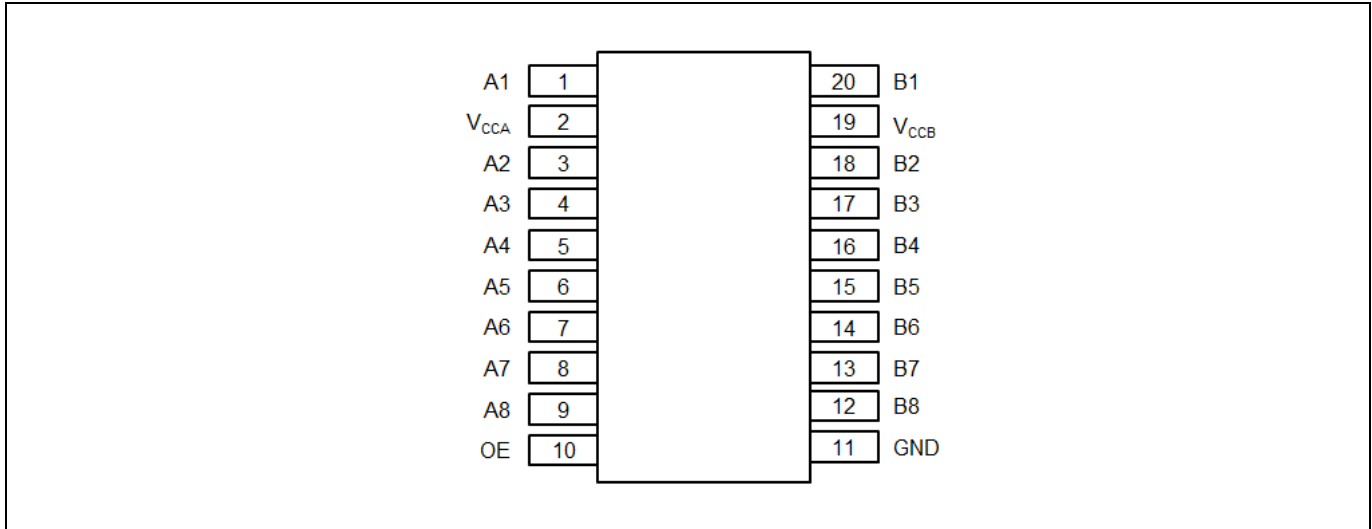

## Pin Description

Pin#	Pin Name	Type	Description
2	VCCA	Power	A-port supply voltage. $1.2V \leq V_{CCA} \leq 3.6V$
19	VCCB	Power	B-port supply voltage. $1.65V \leq V_{CCB} \leq 5.5V$
1	A1	I/O	Input/output A. Referenced to VCCA.
3	A2	I/O	Input/output A. Referenced to VCCA
4	A3	I/O	Input/output A. Referenced to VCCA
5	A4	I/O	Input/output A. Referenced to VCCA
6	A5	I/O	Input/output A. Referenced to VCCA
7	A6	I/O	Input/output A. Referenced to VCCA
8	A7	I/O	Input/output A. Referenced to VCCA
9	A8	I/O	Input/output A. Referenced to VCCA
20	B1	I/O	Input/output B. Referenced to VCCB
18	B2	I/O	Input/output B. Referenced to VCCB
17	B3	I/O	Input/output B. Referenced to VCCB
16	B4	I/O	Input/output B. Referenced to VCCB
15	B5	I/O	Input/output B. Referenced to VCCB
14	B6	I/O	Input/output B. Referenced to VCCB
13	B7	I/O	Input/output B. Referenced to VCCB
12	B8	I/O	Input/output B. Referenced to VCCB
10	OE	Input	Outputs enable (active High). Pull OE low to place all outputs in 3-state mode. Referenced to VCCA.
11	GND	GND	Ground. The exposed center thermal pad must be either be connected to Ground or left electrically opened.

## Maximum Ratings

Storage Temperature.....	-65°C to +150°C
DC Supply Voltage Port B.....	V to +6.5V
DC Supply Voltage Port A.....	V to +4.6V
Vi (A) Referenced DC Input Voltage.....	V to +4.6V
Vi (B) Referenced DC Input Voltage.....	V to +6.5V
Enable Control Pin DC Input Voltage.....	V to +4.6V
Continuous Output Current, I/O.....	30mA
Total Power Dissipation.....	500mW <sup>(2)</sup>

**Note:**

- Stresses greater than those listed under MAXIMUM RATINGS may cause permanent damage to the device. This is a stress rating only and functional operation of the device at these or any other conditions above those indicated in the operational sections of this specification is not implied. Exposure to absolute maximum rating conditions for extended periods may affect reliability.
- Total Power Dissipation derates linearly with 10.0mW/°C above 100°C.

## Recommended Operation Conditions

Symbol	Parameter	Min	Typ	Max	Unit
V <sub>CCA</sub>	V <sub>CCA</sub> Positive DC Supply Voltage	1.2		3.6	V
V <sub>CCB</sub>	V <sub>CCB</sub> Positive DC Supply Voltage	1.65		5.5	V
V <sub>OE</sub>	Enable Control Pin Voltage	GND		5.5	V
V <sub>IO</sub>	A-Port I/O Pin Voltage (A <sub>X</sub> )	GND		V <sub>CCA</sub>	V
	B-Port I/O Pin Voltage (B <sub>X</sub> )	GND		V <sub>CCB</sub>	V
Δt / ΔV	A or B port Push-Pull Driving, (V <sub>CCA</sub> = 1.4V to 3.6V, V <sub>CCB</sub> = 1.65V to 5.5V)			10	ns/V
	OE (V <sub>CCA</sub> = 1.4V to 3.6V, V <sub>CCB</sub> = 1.65V to 3.6V)			10	ns/V
T <sub>A</sub>	Operating Temperature Range	-40		+125	°C

## DC Electrical Characteristics

V<sub>CCI</sub> is the supply voltage associated with the input port. V<sub>CCO</sub> is the supply voltage associated with the output port.

Symbol	Parameter	Test Conditions	V <sub>CCA</sub>	V <sub>CCB</sub>	T <sub>A</sub> = -40°C to 125°C		Unit
					Min	Max	
V <sub>IHA</sub>	A port Input HIGH Voltage		1.2V to 1.95V	1.65V to 5.5V	V <sub>CCI</sub> - 0.2	V <sub>CCI</sub>	V
			1.95V to 3.6V		V <sub>CCI</sub> - 0.4		
V <sub>ILA</sub>	A port Input LOW Voltage		1.2V to 1.95V	1.65V to 5.5V	0	0.15	V
			1.95V to 3.6V				
V <sub>IHB</sub>	B port Input HIGH Voltage		1.2V to 3.6V	1.65V to 5.5V	V <sub>CCI</sub> - 0.4	V <sub>CCI</sub>	V
			1.2V to 3.6V		0		
V <sub>ILB</sub>	B port Input LOW Voltage		1.2V to 3.6V	1.65V to 5.5V	0	0.15	V
V <sub>OHA</sub>	A port Output HIGH Voltage	I <sub>OHA</sub> = -20uA, V <sub>IB</sub> ≥ V <sub>CCB</sub> - 0.4V	1.2V	1.65V to 5.5V	0.67 * V <sub>CCA</sub>		V
V <sub>OLA</sub>	A port Output LOW Voltage	I <sub>OLA</sub> = 180uA, V <sub>IB</sub> ≤ 0.15V	1.4V	1.65V to 5.5V		0.4	V
		I <sub>OLA</sub> = 220uA, V <sub>IB</sub> ≤ 0.15V	1.65V			0.4	V
		I <sub>OLA</sub> = 300uA, V <sub>IB</sub> ≤ 0.15V	2.3V			0.4	V
		I <sub>OLA</sub> = 400uA, V <sub>IB</sub> ≤ 0.15V	3V			0.55	V
V <sub>OHB</sub>	B port Output HIGH Voltage	I <sub>OHB</sub> = -20 uA, V <sub>IA</sub> ≥ V <sub>CCA</sub> - 0.2V	1.2V	1.65V to 5.5V	0.67 * V <sub>CCB</sub>		V
V <sub>OLB</sub>	B port Output LOW Voltage	I <sub>OLB</sub> = 220uA, V <sub>IA</sub> ≤ 0.15V	1.2V to 3.6V	1.65V		0.4	V
		I <sub>OLB</sub> = 300uA, V <sub>IA</sub> ≤ 0.15V		2.3V		0.4	V
		I <sub>OLB</sub> = 400uA, V <sub>IA</sub> ≤ 0.15V		3V		0.55	V
		I <sub>OLB</sub> = 620uA, V <sub>IA</sub> ≤ 0.15V		4.5V		0.55	V
V <sub>IH</sub>	OE Input HIGH Voltage		1.2V to 3.6V	1.65V to 5.5V	0.65 * V <sub>CCA</sub>		V
V <sub>IL</sub>	OE Input LOW Voltage		1.2V to 3.6V	1.65V to 5.5V		0.35 * V <sub>CCA</sub>	V

**LXS0108Q**

Symbol	Parameter	Test Conditions	V <sub>CCA</sub>	V <sub>CCB</sub>	T <sub>A</sub> = -40°C to 125°C		Unit
					Min	Max	
I <sub>I</sub>	Input leakage current	OE, V <sub>I</sub> = V <sub>CCI</sub> or GND	1.2V	1.65V to 5.5V		1	μA
I <sub>OZ</sub>	Off-state Leakage current	A or B port, OE = V <sub>IL</sub>	1.2V	1.65V to 5.5V	-5	3	μA
I <sub>CCA</sub>	V <sub>CCA</sub> Supply Current	V <sub>I</sub> = V <sub>O</sub> = open, I <sub>O</sub> = 0	1.2V	1.65V to 5.5V	-2	16	μA
			1.5V to 3.6V	2.3V to 5.5V		18	
			3.6V	0		16	
			0	5.5V	-3	3	
I <sub>CCB</sub>	V <sub>CCA</sub> Supply Current	V <sub>I</sub> = V <sub>O</sub> = open, I <sub>O</sub> = 0	1.2V	1.65V to 5.5V		31	μA
			1.5V to 3.6V	2.3V to 5.5V		31	
			3.6V	0	-3	3	
			0	5.5V		16	
I <sub>CCA</sub> + I <sub>CCB</sub>	Total Supply current	V <sub>I</sub> = V <sub>CCI</sub> or GND, I <sub>O</sub> = 0	1.2V	2.3V to 5.5V		40	μA
			1.5V to 3.6V	2.3V to 5.5V		42	
I <sub>CCZA</sub>	Off-state V <sub>CCA</sub> Supply	V <sub>I</sub> = V <sub>O</sub> = Open, I <sub>O</sub> = 0, OE = GND	1.2V	1.65V to 5.5V		15	μA
I <sub>CCZB</sub>	Off-state V <sub>CCB</sub> Supply	V <sub>I</sub> = V <sub>O</sub> = Open, I <sub>O</sub> = 0, OE = GND	1.2V	1.65V to 5.5V		15	μA
C <sub>I</sub>	Input Capacitance	OE	3.3V	3.3V		5.5	pF
C <sub>IO</sub>	Input-to-output Capacitance	A Port	3.3V	3.3V		7.5	pF
		B Port	3.3V	3.3V		7.5	pF

## Timing Requirements

Temperature Range: -40°C to 125°C

$V_{CCA} = 1.2V$			$V_{CCB} = 1.8V \pm 0.15V$		$V_{CCB} = 2.5V \pm 0.2V$		$V_{CCB} = 3.3V \pm 0.3V$		$V_{CCB} = 5V \pm 0.5V$		Unit
			MIN	MAX	MIN	MAX	MIN	MAX	MIN	MAX	
Data Rate	Push-Pull			20		20		20		20	Mbps
	Open-Drain			0.6		0.6		0.6		0.6	
t <sub>w</sub> Pulse Duration	Data Input	Push-Pull	50		50		50		50		ns
		Open-Drain	1250		1250		1250		1250		

$V_{CCA} = 1.5V \pm 0.1V$			$V_{CCB} = 1.8V \pm 0.15V$		$V_{CCB} = 2.5V \pm 0.2V$		$V_{CCB} = 3.3V \pm 0.3V$		$V_{CCB} = 5V \pm 0.5V$		Unit
			MIN	MAX	MIN	MAX	MIN	MAX	MIN	MAX	
Data Rate	Push-Pull			40		40		40		40	Mbps
	Open-Drain			0.7		0.7		0.7		0.7	
t <sub>w</sub> Pulse Duration	Data Input	Push-Pull	25		25		25		25		ns
		Open-Drain	1250		1250		1250		1250		

$V_{CCA} = 1.8V \pm 0.15V$			$V_{CCB} = 1.8V \pm 0.15V$		$V_{CCB} = 2.5V \pm 0.2V$		$V_{CCB} = 3.3V \pm 0.3V$		$V_{CCB} = 5V \pm 0.5V$		Unit
			MIN	MAX	MIN	MAX	MIN	MAX	MIN	MAX	
Data Rate	Push-Pull			40		50		50		50	Mbps
	Open-Drain			0.8		0.8		0.8		0.8	
t <sub>w</sub> Pulse Duration	Data Input	Push-Pull	25		20		20		20		ns
		Open-Drain	1250		1250		1250		1250		

$V_{CCA} = 2.5V \pm 0.2V$			$V_{CCB} = 2.5V \pm 0.2V$		$V_{CCB} = 3.3V \pm 0.3V$		$V_{CCB} = 5V \pm 0.5V$		Unit
			MIN	MAX	MIN	MAX	MIN	MAX	
Data Rate	Push-Pull			60		80		80	Mbps
	Open-Drain			0.8		0.8		0.8	
t <sub>w</sub> Pulse Duration	Data Input	Push-Pull	16.7		12.5		12.5		ns
		Open-Drain	1250		1250		1250		

$V_{CCA} = 3.3V \pm 0.3V$			$V_{CCB} = 3.3V \pm 0.3V$		$V_{CCB} = 5V \pm 0.5V$		Unit
			MIN	MAX	MIN	MAX	
Data Rate	Push-Pull			90		110	Mbps
	Open-Drain			0.8		0.8	
t <sub>w</sub> Pulse Duration	Data Input	Push-Pull	11		9		ns
		Open-Drain	625		625		

### AC Electrical Characteristics

I/O test circuits of Figures 2, 3, 4 & 5,  $C_{LOAD} = 15pF$ ,  $R_{LOAD} = 1M\Omega$ , input pulse generator having the following characteristics:  $Z_0 = 50\Omega$ ,  $PRR \leq 10MHz$ ,  $dv/dt \geq 1V/ns$

$V_{CCA} = 1.2V \pm 0.1V$ , Temperature Range:  $-40^\circ C$  to  $125^\circ C$

Symbol	Parameter	Test Conditions	$V_{CCB} = 1.8V \pm 0.15V$		$V_{CCB} = 2.5V \pm 0.2V$		$V_{CCB} = 3.3V \pm 0.3V$		$V_{CCB} = 5.0V \pm 0.5V$		Unit
			Min	Max	Min	Max	Min	Max	Min	Max	
$t_{PHL-A-B}$	High to Low propagation delay	Push-Pull driving		15.8		14.5		13.8		12.8	ns
		Open-Drain driving		17.4		16.8		15.2		13.9	
$t_{PLH-A-B}$	Low to High propagation delay	Push-Pull driving		17.8		14.5		13.3		12.5	ns
		Open-Drain driving		745		581		495		414	
$t_{PHL-B-A}$	High to Low propagation delay	Push-Pull driving		18.9		17.9		16.8		15.8	ns
		Open-Drain driving		16.2		13.6		12.5		11.5	
$t_{PLH-B-A}$	Low to High propagation delay	Push-Pull driving		16.1		13.6		12.7		12.8	ns
		Open-Drain driving		775		635		540		438	
$t_{en}$	Enable Time	OE to A or B		200		200		200		300	ns
$t_{dis}$	Disable Time	OE to A or B		28.1		22		20.1		19.6	ns
$t_{RA}$	A port Rise Time	Push-Pull driving		18.4		15.3		14.3		13.4	ns
		Open-Drain driving		981		782		719		635	
$t_{RB}$	B port Rise Time	Push-Pull driving		18.1		15.1		12.6		10.8	ns
		Open-Drain driving		1080		825		793		790	
$t_{FA}$	A port Fall Time	Push-Pull driving		14.5		12.5		11.4		9.8	ns
		Open-Drain driving		15.4		13.6		12.5		9.5	
$t_{FB}$	B port Fall Time	Push-Pull driving		12.9		10.9		10.6		9.2	ns
		Open-Drain driving		13.5		11.6		11.5		10.7	
$t_{PPSKEW}$	Channel-to-Channel Skew	-		1.2		1.2		1.2		1.2	ns
$f_{DATA}$	Maximum Data Rate	Push-Pull driving		20		20		20		20	Mbps
		Open-Drain driving		0.6		0.6		0.6		0.6	

$V_{CCA} = 1.5V \pm 0.1V$ , Temperature Range:  $-40^\circ C$  to  $125^\circ C$

Symbol	Parameter	Test Conditions	$V_{CCB} = 1.8V \pm 0.15V$		$V_{CCB} = 2.5V \pm 0.2V$		$V_{CCB} = 3.3V \pm 0.3V$		$V_{CCB} = 5.0V \pm 0.5V$		Unit
			Min	Max	Min	Max	Min	Max	Min	Max	
$t_{PHL-A-B}$	High to Low propagation delay	Push-Pull driving		13.8		11.5		10.8		10.8	ns
		Open-Drain driving		14.4		12.8		12.2		12	
$t_{PLH-A-B}$	Low to High propagation delay	Push-Pull driving		15.8		12.5		12.3		12.1	ns
		Open-Drain driving		720		554		473		384	
$t_{PHL-B-A}$	High to Low propagation delay	Push-Pull driving		15.9		13.9		13.8		15	ns
		Open-Drain driving		13.2		9.6		8.5		7.5	
$t_{PLH-B-A}$	Low to High propagation delay	Push-Pull driving		13.1		8.6		7		5.8	ns
		Open-Drain driving		745		603		519		407	
$t_{en}$	Enable Time	OE to A or B		200		200		200		300	ns
$t_{dis}$	Disable Time	OE to A or B		28.1		22		20.1		19.6	ns
$t_{RA}$	A port Rise Time	Push-Pull driving		16.4		12.3		11.3		10.4	ns
		Open-Drain driving		982		756		692		610	
$t_{RB}$	B port Rise Time	Push-Pull driving		16.1		10.1		9.6		8.8	ns

Symbol	Parameter	Test Conditions	$V_{CCB} = 1.8V \pm 0.15V$		$V_{CCB} = 2.5V \pm 0.2V$		$V_{CCB} = 3.3V \pm 0.3V$		$V_{CCB} = 5.0V \pm 0.5V$		Unit
			Min	Max	Min	Max	Min	Max	Min	Max	
		Open-Drain driving		1020		756		753		780	
$t_{FA}$	A port Fall Time	Push-Pull driving		11.4		9.5		8.1		7.2	ns
		Open-Drain driving		12.4		9.6		8.5		7.5	
$t_{FB}$	B port Fall Time	Push-Pull driving		10.9		6.9		6.6		5.9	ns
		Open-Drain driving		11.5		8.6		8.5		7.7	
$t_{PPSKEW}$	Channel-to-Channel Skew	-		1.1		1.1		1.1		1.1	ns
$f_{DATA}$	Maximum Data Rate	Push-Pull driving		40		40		40		40	Mbps
		Open-Drain driving		0.7		0.7		0.7		0.7	

 **$V_{CCA} = 1.8V \pm 0.15V$ , Temperature Range:  $-40^{\circ}C$  to  $125^{\circ}C$** 

Symbol	Parameter	Test Conditions	$V_{CCB} = 1.8V \pm 0.15V$		$V_{CCB} = 2.5V \pm 0.2V$		$V_{CCB} = 3.3V \pm 0.3V$		$V_{CCB} = 5.0V \pm 0.5V$		Unit
			Min	Max	Min	Max	Min	Max	Min	Max	
$t_{PHL-A-B}$	High to Low propagation delay	Push-Pull driving		12.1		9.1		8.1		7.4	ns
		Open-Drain driving		11.4		9.9		9.3		8.9	
$t_{PLH-A-B}$	Low to High propagation delay	Push-Pull driving		14.1		10.5		9.3		8.1	ns
		Open-Drain driving		729		584		466		346	
$t_{PHL-B-A}$	High to Low propagation delay	Push-Pull driving		12.3		10		9.3		8.8	ns
		Open-Drain driving		12.1		8.5		7.3		6.5	
$t_{PLH-B-A}$	Low to High propagation delay	Push-Pull driving		12.8		8.8		7.3		6.3	ns
		Open-Drain driving		733		578		459		323	
$t_{en}$	Enable Time	OE to A or B		200		200		200		200	ns
$t_{dis}$	Disable Time	OE to A or B		25.1		18.8		18.8		18.8	ns
$t_{RA}$	A port Rise Time	Push-Pull driving		14.9		10.8		9.8		9	ns
		Open-Drain driving		996		691		508		350	
$t_{RB}$	B port Rise Time	Push-Pull driving		15.3		11.6		8.6		8.6	ns
		Open-Drain driving		1001		677		546		323	
$t_{FA}$	A port Fall Time	Push-Pull driving		11		10.3		9.1		9.1	ns
		Open-Drain driving		9		6.7		5.8		5.2	
$t_{FB}$	B port Fall Time	Push-Pull driving		10.4		8.8		4.9		4.8	ns
		Open-Drain driving		10.5		10.3		9.6		7.8	
$t_{PPSKEW}$	Channel-to-Channel Skew	-		1.1		1.1		1.1		1.1	ns
$f_{DATA}$	Maximum Data Rate	Push-Pull driving		40		50		50		50	Mbps
		Open-Drain driving		0.8		0.8		0.8		0.8	

 **$V_{CCA} = 2.5V \pm 0.2V$ , Temperature Range:  $-40^{\circ}C$  to  $125^{\circ}C$** 

Symbol	Parameter	Test Conditions	$V_{CCB} = 2.5V \pm 0.2V$		$V_{CCB} = 3.3V \pm 0.3V$		$V_{CCB} = 5.0V \pm 0.5V$		Unit
			Min	Max	Min	Max	Min	Max	
$t_{PHL-A-B}$	High to Low propagation delay	Push-Pull driving		7.8		6.6		5.9	ns
		Open-Drain driving		6.9		6.3		5.8	
$t_{PLH-A-B}$	Low to High propagation delay	Push-Pull driving		8.5		7.4		6.5	ns
		Open-Drain driving		592		488		368	
$t_{PHL-B-A}$	High to Low	Push-Pull driving		7.4		6		5.3	ns

Symbol	Parameter	Test Conditions	V <sub>CCB</sub> = 2.5V ± 0.2V		V <sub>CCB</sub> = 3.3V ± 0.3V		V <sub>CCB</sub> = 5.0V ± 0.5V		Unit
			Min	Max	Min	Max	Min	Max	
	propagation delay	Open-Drain driving		523		441		428	
t <sub>PLH-B-A</sub>	Low to High propagation delay	Push-Pull driving		7.8		7.5		4.5	ns
		Open-Drain driving		595		481		345	
t <sub>en</sub>	Enable Time	OE to A or B		200		200		200	ns
t <sub>dis</sub>	Disable Time	OE to A or B		15.7		12.9		11.2	ns
t <sub>RA</sub>	A port Rise Time	Push-Pull driving		9.1		8		7.3	ns
		Open-Drain driving		692		529		389	
t <sub>RB</sub>	B port Rise Time	Push-Pull driving		9.1		6.8		4.1	ns
		Open-Drain driving		693		483		304	
t <sub>FA</sub>	A port Fall Time	Push-Pull driving		7.1		5.9		5.5	ns
		Open-Drain driving		5.6		4.7		4	
t <sub>FB</sub>	B port Fall Time	Push-Pull driving		6.8		5.1		4.2	ns
		Open-Drain driving		14.2		19.4		3	
t <sub>PPSKEW</sub>	Channel-to-Channel Skew			1.1		1.1		1.1	ns
f <sub>DATA</sub>	Maximum Data Rate	Push-Pull driving		60		80		80	Mbps
		Open-Drain driving		0.8		0.8		0.8	

**V<sub>CCA</sub> = 3.3V ± 0.3V, Temperature Range: -40°C to 125°C**

Symbol	Parameter	Test Conditions	V <sub>CCB</sub> = 3.3V ± 0.3V		V <sub>CCB</sub> = 5.0V ± 0.5V		Unit
			Min	Max	Min	Max	
t <sub>PHL-A-B</sub>	High to Low propagation delay	Push-Pull driving		6.1		5.3	ns
		Open-Drain driving		429		332	
t <sub>PLH-A-B</sub>	Low to High propagation delay	Push-Pull driving		7.9		7.5	ns
		Open-Drain driving		439		352	
t <sub>PHL-B-A</sub>	High to Low propagation delay	Push-Pull driving		5.9		4.8	ns
		Open-Drain driving		5.5		4.5	
t <sub>PLH-B-A</sub>	Low to High propagation delay	Push-Pull driving		5.9		5.4	ns
		Open-Drain driving		449		339	
t <sub>en</sub>	Enable Time	OE to A or B		200		200	ns
t <sub>dis</sub>	Disable Time	OE to A or B		11.9		9.8	ns
t <sub>RA</sub>	A port Rise Time	Push-Pull driving		7.1		6.3	ns
		Open-Drain driving		446		337	
t <sub>RB</sub>	B port Rise Time	Push-Pull driving		6.8		4.9	ns
		Open-Drain driving		427		290	
t <sub>FA</sub>	A port Fall Time	Push-Pull driving		5.6		4.4	ns
		Open-Drain driving		4.5		3.5	
t <sub>FB</sub>	B port Fall Time	Push-Pull driving		5.3		3.9	ns
		Open-Drain driving		4.2		3.1	
t <sub>PPSKEW</sub>	Channel-to-Channel Skew			1.1		1.1	ns
f <sub>DATA</sub>	Maximum Data Rate	Push-Pull driving		90		110	Mbps
		Open-Drain driving		0.8		0.8	



**Test Circuits**

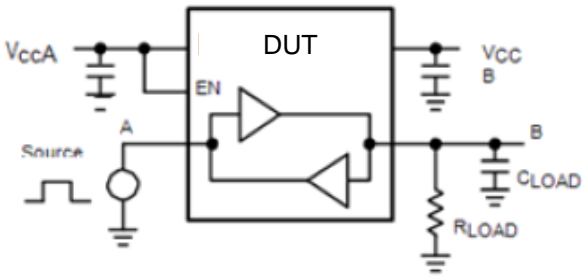

Figure 2: Rail-to-Rail Driving A

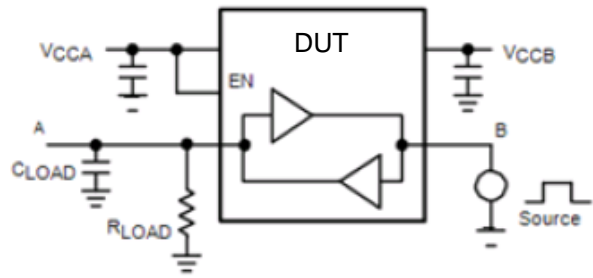

Figure 3: Rail-to-Rail Driving B

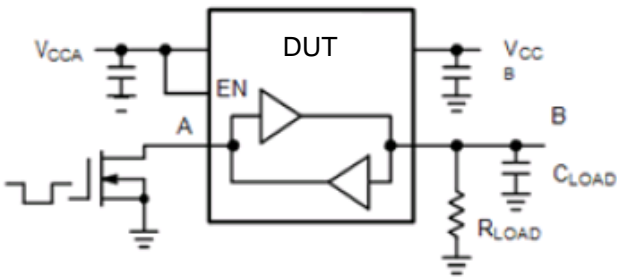

Figure 4: Open-Drain Driving A

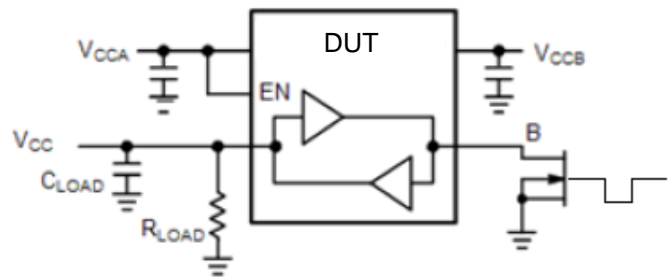
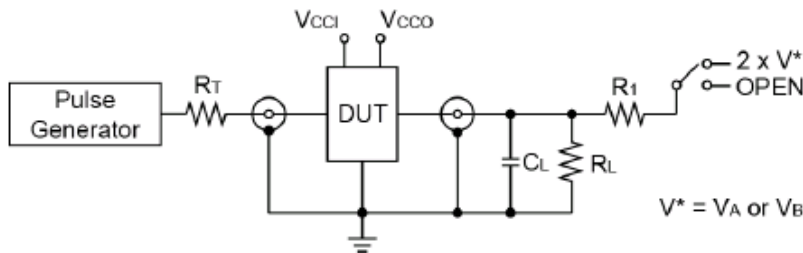

Figure 5: Open-Drain Driving B



Test	Switch
$t_{pZH}$ , $t_{pHZ}$	Open
$t_{pZL}$ , $t_{pLZ}$	$2 \times V^*$

$C_L = 15\text{pF}$

$R_L = R_1 = 50\text{k}\Omega$

$R_T = Z_{OUT}$  of pulse generator (Typically  $50\Omega$ )

$V^* = V_A$  or  $V_B$  for A or B measurements, respectively.

Figure 6: Test Circuit for Enable/Disable Time Measurement

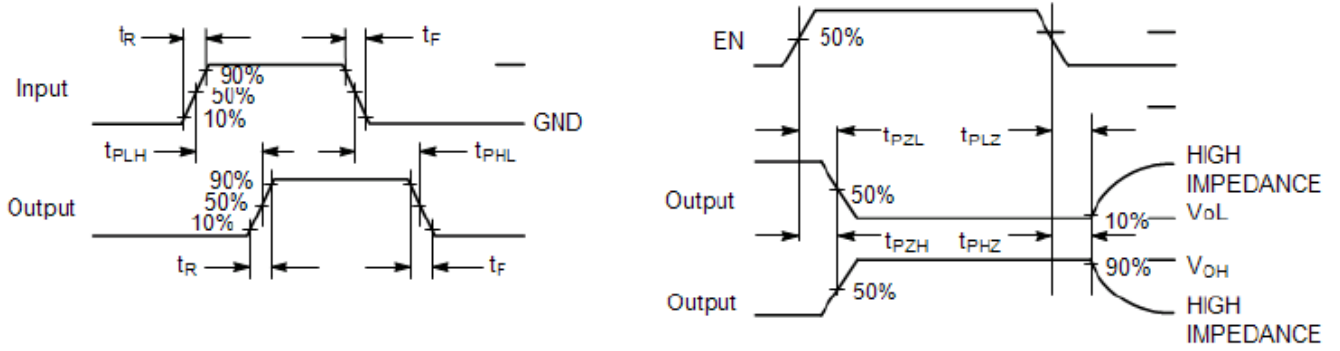

**Figure 7: Timing Definitions for Propagation Delays and Enable/Disable Measurement**

## Functional Description

### Level Translator Architecture

The LXS0108Q is a 8-bit configurable dual supply level shifter with edge rate accelerators (one shots) to improve the overall data rate. The A port operating voltage range is from 1.2V to 3.6V, and the B port is from 1.65V to 5.5V. While this device is designed for open drain applications, the device can also translate push-pull CMOS logic outputs.

The device has integrated a pull-up resistor on each I/O pin. This pull-up resistor is used to pull the I/O line to either  $V_{CCA}$  (called  $R_{PUA}$ ) or  $V_{CCB}$  (called  $R_{PUB}$ ). When the output is driving low,  $R_{PUA}$  and  $R_{PUB}$  are set to 40k $\Omega$  resistors. In contrast, When the output is driving high,  $R_{PUA}$  and  $R_{PUB}$  are set to 40k $\Omega$  resistors because this feature provides a lower static power consumption, a lower VOL values, and a faster simultaneous switching performance.  $R_{PUA}$  and  $R_{PUB}$  are disabled when OE is Low to switch off the device.

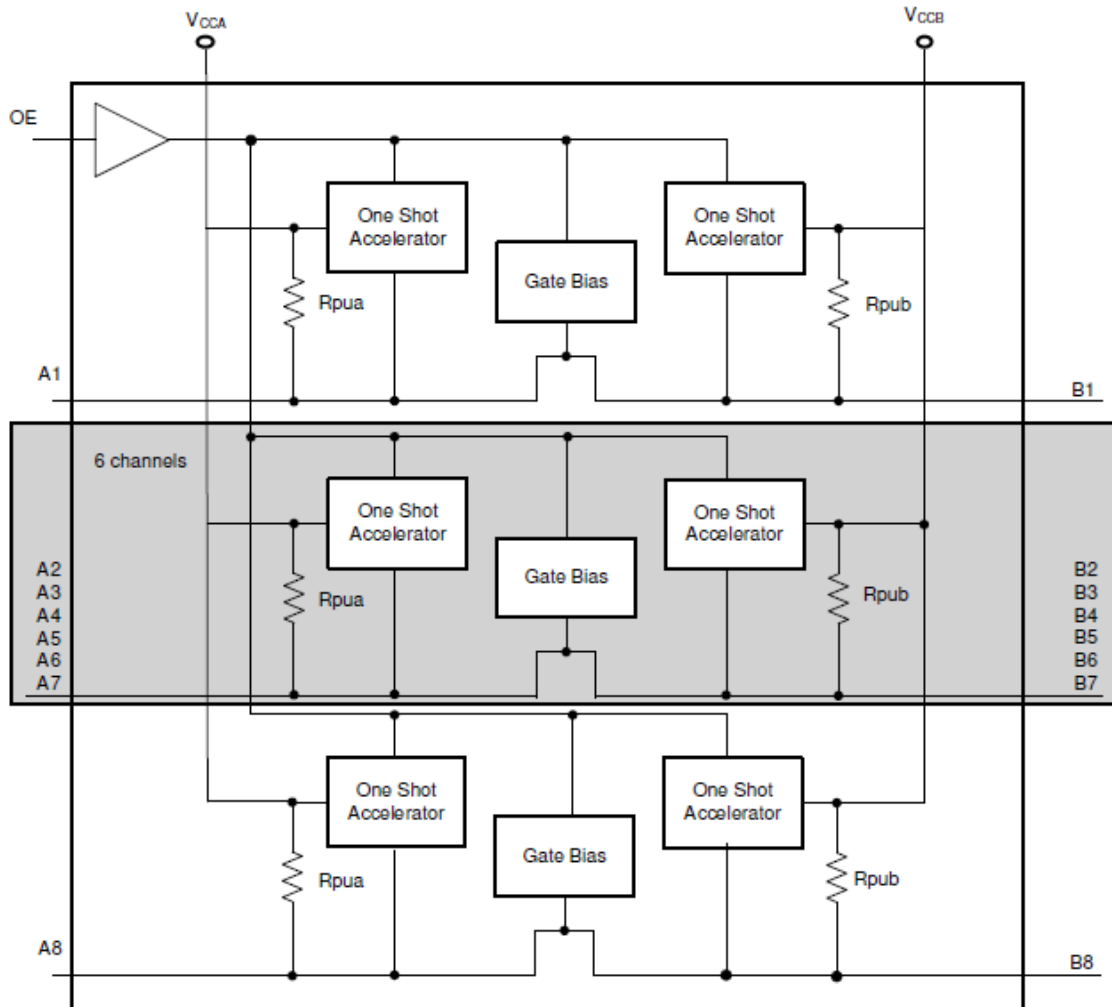

Figure 8. Functional Block Diagram

### Input Driver Requirements

The rise and fall time of a signal depends on the edge-rate and output impedance of the external device driving LXS0108Q data I/Os, as well as the capacitive load on the data lines. Similarly, the propagating delay and maximum data rates also depend on the output impedance of the external driver. The AC timing parameters listed in the datasheet assume that the output impedance of the external drivers is less than 50 $\Omega$ .

### Output Enable and Disable (OE)

The LXS0108Q has an Output Enable pin (OE) that enables the device by active-high. In contrast, setting the OE pin to a logic low state can switch off the device to a minimize power consumption with all I/Os in high-impedance. Normal translation occurs when the OE pin is equal to a logic high state where the OE pin is referenced to the  $V_{CCA}$  supply rail.

### Output Load Considerations

Care shall be taken consideration careful for PCB trace lengths to avoid excessive capacitive loading and to ensure that proper one-shot triggering takes place. PCB signal trace-lengths should be kept short enough such that the round-trip delay of any reflection is less than the one-shot duration, which is approximately 30ns. The maximum capacitance of the lumped load that can be driven also depends directly on the one-shot duration. With very heavy capacitive loads, the one-shot can time-out before the signal is driven fully to the positive rail. Both PCB trace length and connectors add to the capacitance of the LXS0108Q output. Therefore, the lumped-load capacitance shall be considered in order to avoid one-shot retriggering, or bus contention, or output signal oscillations.

### Power Supply Guidelines

For normal operation, the  $V_{CCA}$  must be less than or equal to  $V_{CCB}$  where the LXS0108Q does not require power sequencing between  $V_{CCA}$  and  $V_{CCB}$  during power-up. To minimize power noise from supply rails, decouple capacitors, 0.01 $\mu$ F to 0.1 $\mu$ F should be placed as closed as  $V_{CCA}$  and  $V_{CCB}$ . The PCB trace of signals must be kept short enough so that the round-trip delay of any reflection is less than the one-shot duration, approximately 30ns.

LXS0108Q

**Part Marking**

LXS01  
08Q1LE  
YYWWXX

YY: Date Code (Year)  
WW: Date Code (Workweek)  
1st X: Assembly Code  
2nd X: Fab Code  
Bar above 2nd "X" means Cu wire

**Packaging Mechanical**

**20-TSSOP (L)**

SYMBOLS	MIN.	NOM.	MAX.
A	–	–	1.20
A1	0.05	–	0.15
A2	0.80	1.00	1.05
b	0.19	–	0.30
C	0.09	–	0.20
D	6.40	6.50	6.60
E1	4.30	4.40	4.50
E	6.20	6.40	6.60
e	0.65 BSC		
L1	1.00 REF		
L	0.45	0.60	0.75
S	0.20	–	–
θ	0°	–	8°

**NOTES:**  
 1. ALL DIMENSIONS IN MILLIMETERS. ANGLES IN DEGREES.  
 2. JEDEC MO-153F  
 3. DIMENSIONS DOES NOT INCLUDE MOLD FLASH, PROTRUSIONS OR GATE BURRS.

	<b>DATE: 03/31/16</b>
<b>DESCRIPTION: 20-Pin, 173mil Wide TSSOP</b>	
<b>PACKAGE CODE: L (L20)</b>	
<b>DOCUMENT CONTROL #: PD-1311</b>	<b>REVISION: G</b>

16-0074

**For latest package info.**

please check: <http://www.diodes.com/design/support/packaging/pericom-packaging/packaging-mechanicals-and-thermal-characteristics/>

**Ordering Information**

Part Number	Package Code	Package Description
LXS0108QLEX	L	20-pin, 173mil Wide (TSSOP)

- Notes:**
- No purposely added lead. Fully EU Directive 2002/95/EC (RoHS), 2011/65/EU (RoHS 2) & 2015/863/EU (RoHS 3) compliant.
  - See <https://www.diodes.com/quality/lead-free/> for more information about Diodes Incorporated's definitions of Halogen- and Antimony-free, "Green" and Lead-free.
  - Halogen- and Antimony-free "Green" products are defined as those which contain <900ppm bromine, <900ppm chlorine (<1500ppm total Br + Cl) and <1000ppm antimony compounds.
  - Q = Automotive Compliant
  - E = Pb-free and Green
  - X suffix = Tape/Reel

**IMPORTANT NOTICE**

1. DIODES INCORPORATED (Diodes) AND ITS SUBSIDIARIES MAKE NO WARRANTY OF ANY KIND, EXPRESS OR IMPLIED, WITH REGARDS TO ANY INFORMATION CONTAINED IN THIS DOCUMENT, INCLUDING, BUT NOT LIMITED TO, THE IMPLIED WARRANTIES OF MERCHANTABILITY, FITNESS FOR A PARTICULAR PURPOSE OR NON-INFRINGEMENT OF THIRD PARTY INTELLECTUAL PROPERTY RIGHTS (AND THEIR EQUIVALENTS UNDER THE LAWS OF ANY JURISDICTION).
2. The Information contained herein is for informational purpose only and is provided only to illustrate the operation of Diodes' products described herein and application examples. Diodes does not assume any liability arising out of the application or use of this document or any product described herein. This document is intended for skilled and technically trained engineering customers and users who design with Diodes' products. Diodes' products may be used to facilitate safety-related applications; however, in all instances customers and users are responsible for (a) selecting the appropriate Diodes products for their applications, (b) evaluating the suitability of Diodes' products for their intended applications, (c) ensuring their applications, which incorporate Diodes' products, comply the applicable legal and regulatory requirements as well as safety and functional-safety related standards, and (d) ensuring they design with appropriate safeguards (including testing, validation, quality control techniques, redundancy, malfunction prevention, and appropriate treatment for aging degradation) to minimize the risks associated with their applications.
3. Diodes assumes no liability for any application-related information, support, assistance or feedback that may be provided by Diodes from time to time. Any customer or user of this document or products described herein will assume all risks and liabilities associated with such use, and will hold Diodes and all companies whose products are represented herein or on Diodes' websites, harmless against all damages and liabilities.
4. Products described herein may be covered by one or more United States, international or foreign patents and pending patent applications. Product names and markings noted herein may also be covered by one or more United States, international or foreign trademarks and trademark applications. Diodes does not convey any license under any of its intellectual property rights or the rights of any third parties (including third parties whose products and services may be described in this document or on Diodes' website) under this document.
5. Diodes' products are provided subject to Diodes' Standard Terms and Conditions of Sale (<https://www.diodes.com/about/company/terms-and-conditions/terms-and-conditions-of-sales/>) or other applicable terms. This document does not alter or expand the applicable warranties provided by Diodes. Diodes does not warrant or accept any liability whatsoever in respect of any products purchased through unauthorized sales channel.
6. Diodes' products and technology may not be used for or incorporated into any products or systems whose manufacture, use or sale is prohibited under any applicable laws and regulations. Should customers or users use Diodes' products in contravention of any applicable laws or regulations, or for any unintended or unauthorized application, customers and users will (a) be solely responsible for any damages, losses or penalties arising in connection therewith or as a result thereof, and (b) indemnify and hold Diodes and its representatives and agents harmless against any and all claims, damages, expenses, and attorney fees arising out of, directly or indirectly, any claim relating to any noncompliance with the applicable laws and regulations, as well as any unintended or unauthorized application.
7. While efforts have been made to ensure the information contained in this document is accurate, complete and current, it may contain technical inaccuracies, omissions and typographical errors. Diodes does not warrant that information contained in this document is error-free and Diodes is under no obligation to update or otherwise correct this information. Notwithstanding the foregoing, Diodes reserves the right to make modifications, enhancements, improvements, corrections or other changes without further notice to this document and any product described herein. This document is written in English but may be translated into multiple languages for reference. Only the English version of this document is the final and determinative format released by Diodes.
8. Any unauthorized copying, modification, distribution, transmission, display or other use of this document (or any portion hereof) is prohibited. Diodes assumes no responsibility for any losses incurred by the customers or users or any third parties arising from any such unauthorized use.
9. This Notice may be periodically updated with the most recent version available at <https://www.diodes.com/about/company/terms-and-conditions/important-notice>

The Diodes logo is a registered trademark of Diodes Incorporated in the United States and other countries.  
All other trademarks are the property of their respective owners.  
© 2024 Diodes Incorporated. All Rights Reserved.

[www.diodes.com](http://www.diodes.com)