

Description

The PAM3108 is a high performance positive voltage regulator designed for use in applications requiring very low Input voltage and very low dropout voltage at up to 1.5A. It operates with a V_{IN} as low as 1.1V and V_{DD} voltage 3V with output voltage programmable as low as 0.8V. The significant feature includes ultra low dropout, ideal for applications where V_{OUT} is very close to V_{IN} . Additionally, there is an enable pin to further reduce power dissipation while shutdown. The PAM3108 provides excellent regulation over variations in line, load, temperature and provides a power OK signal to indicate if the voltage level of V_o reaches 90% of its rating value.

The PAM3108 is available with SOP-8 (Exposed Pad) and WDFN-10L 3x3 packages.

Features

- Maximum 1.5A Low-Dropout Voltage Regulator
- High Accuracy Output Voltage $\pm 1.5\%$
- Typically 150mV Dropout at 1.5A
- Power Good Output
- Output Voltage Pull Low Resistance when Disabled
- Thermal and Over Current Protection
- RoHS Compliant and 100% Lead (Pb)-Free

Pin Assignments

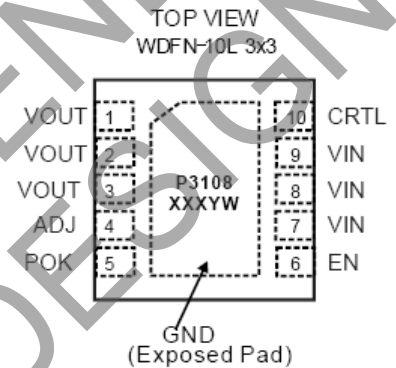
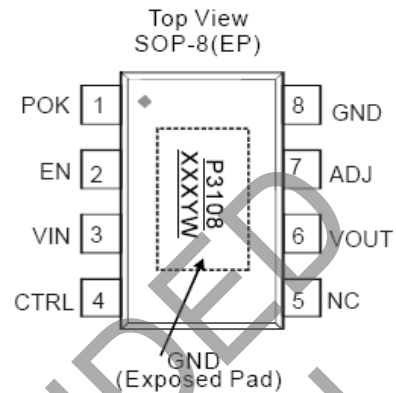

Applications

- Front Side Bus VTT (1.2V/1.5A)
- NoteBook PC Applications
- Motherboard Applications

Typical Applications Circuit

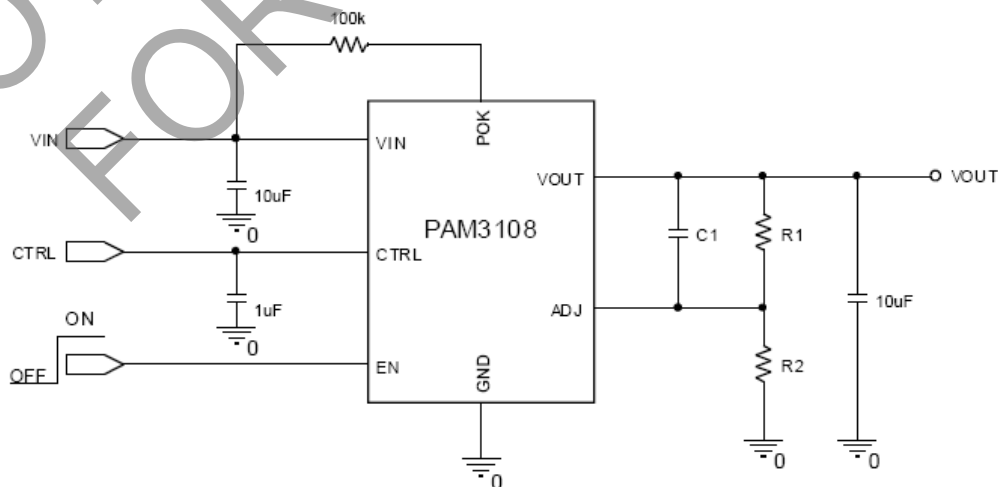

$$V_o = 0.8V \cdot (1 + R1/R2)$$

Pin Configuration and Description

| Pin Name | Pin Number | | Function |
|----------|--------------------|------------------|---|
| | SOP-8(EP) | W-DFN3x3-10 | |
| VIN | 3 | 7, 8, 9 | Supply Input Voltage. |
| EN | 2 | 6 | Chip Enable (Active-High). |
| CTRL | 4 | 10 | Supply Voltage of Control Circuitry. |
| POK | 1 | 5 | Power Good Open Drain Output. |
| ADJ | 7 | 4 | Set the output voltage by the feedback resistors. $V_O = 0.8V \times (R1 + R2)/R2$. |
| VOUT | 6 | 1, 2, 3 | Output Voltage. |
| NC | 5 | — | No Internal Connection. |
| GND | 8, Exposed Pad (9) | Exposed Pad (11) | Ground. The exposed pad must be soldered to a large PCB and connected to GND for maximum power dissipation. |

Functional Block Diagram

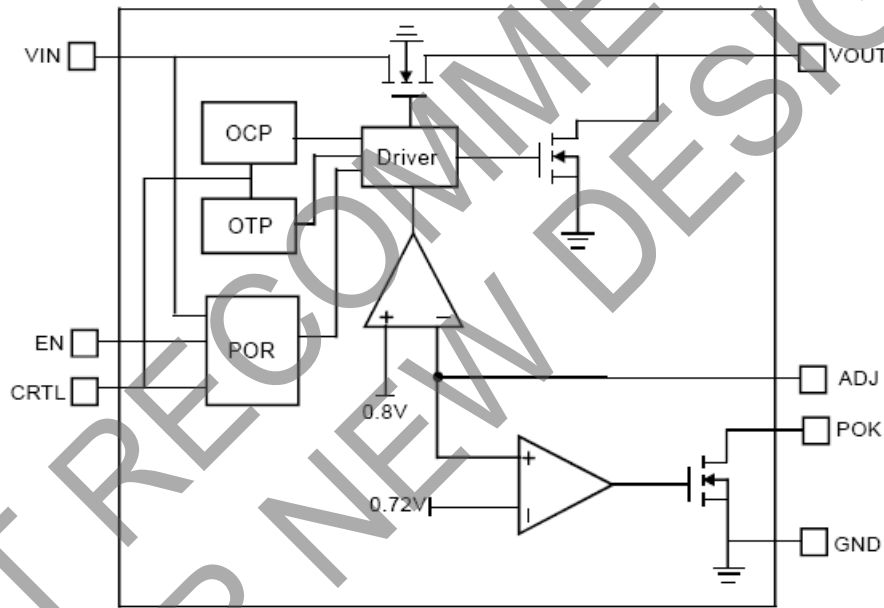

Absolute Maximum Ratings (@T_A = +25°C, unless otherwise specified.)

These are stress ratings only and functional operation is not implied. Exposure to absolute maximum ratings for prolonged time periods may affect device reliability. All voltages are with respect to ground.

| Parameter | Rating | Unit |
|--------------------------------------|----------------------------------|------|
| Input Voltage V _{IN} , CTRL | 6.0 | V |
| Output Current | 1.5 | A |
| Output Pin Voltage | GND -0.3 to V _{IN} +0.3 | V |
| Lead Soldering Temperature | 260, (5sec) | °C |
| Storage Temperature | -65 to +150 | °C |
| ESD Rating | Class B | — |

Recommended Operating Conditions (@T_A = +25°C, unless otherwise specified.)

| Parameter | Rating | Unit |
|-----------------------|-------------|------|
| Max. Supply Voltage | 5.5 | V |
| Junction Temperature | -40 to +125 | °C |
| Operation Temperature | -40 to +85 | |

Thermal Information

| Parameter | Symbol | Package | Max | Unit |
|---|----------------|-------------|------|------|
| Thermal Resistance Junction to Case) | θ_{JC} | W-DFN3x3-10 | 8.5 | °C/W |
| | | SOP-8(EP) | 11 | |
| Thermal Resistance (Junction to Ambient) | θ_{JA} | W-DFN3x3-10 | 60 | |
| | | SOP-8(EP) | 90 | |
| Internal Power Dissipation (@T _A = 25°C) | P _D | W-DFN3x3-10 | 1600 | mW |
| | | SOP-8(EP) | 1100 | |

Electrical Characteristics (@ $T_A = +25^\circ\text{C}$, $V_{IN} = V_O + 0.5\text{V}$, $V_{CTRL} = V_{EN} = 5\text{V}$, $C_{IN} = C_O = 10\mu\text{F}$, unless otherwise specified.)

| Parameter | Symbol | Test Conditions | Min | Typ | Max | Units |
|--------------------------------|-----------------|---|--------------------|------|-------|-----------------------|
| VIN Input Voltage | V_{IN} | $V_{OUT} = V_{REF}$ | 1.1 | | 5.5 | V |
| CTRL Input Voltage | V_{CTRL} | | 3 | | 5.5 | V |
| POR Threshold | V_{TH_CTRL} | | 2.5 | 2.7 | | V |
| | V_{TH_VIN} | | 0.8 | 0.9 | | |
| POR Hysteresis | V_{YHS_CTRL} | | | 0.4 | | |
| | V_{YHS_VIN} | | | 0.5 | | |
| Quiescent Current | I_Q | $I_O = 0\text{mA}$ | | 0.5 | 1.2 | mA |
| CTRL Input Current in Shutdown | I_{SD_CTRL} | $V_{EN} = 0\text{V}$ | | 5 | | μA |
| CTRL Input Current in Shutdown | I_{SD_VIN} | $V_{EN} = 0\text{V}$ | | | 1 | μA |
| Output Voltage Accuracy | V_O | $I_O = 1\text{mA to } 1.5\text{A}$ | -1.5 | | 1.5 | % |
| Current Limit | I_O | | | 3 | | A |
| Short Current | I_{SHORT} | $V_O = 0\text{V}$ | | 1 | | A |
| Feedback Voltage | V_{REF} | $V_O = V_{REF}$ | 0.788 | 0.8 | 0.812 | V |
| Feedback Leakage Current | I_{REF} | | | | 20 | nA |
| Dropout Voltage | V_{DROP} | $I_O = 1\text{A}$ | | 100 | | mV |
| | | $I_O = 1.5\text{A}$ | | 150 | | |
| Line Regulation | LNR | $I_O = 1\text{mA}$, $V_{IN} = V_O = 0.5\text{V to } 5.5\text{V}$ | -0.15 | 0.1 | 0.15 | %/V |
| Load Regulation | LDR | $V_{IN} = V_O + 1\text{V}$, $I_O = 1\text{mA to } 1.5\text{A}$ | -2.0 | +0.2 | +2.0 | % |
| VOUT Pull Low Resistor | RPL | $V_{EN} = 0\text{V}$ | | 100 | | Ω |
| Temperature Coefficient | T_C | $I_O = 1\text{mA}$ | | 40 | | ppm/ $^\circ\text{C}$ |
| Over Temperature Shutdown | OTS | $I_O = 1\text{mA}$ | | 170 | | $^\circ\text{C}$ |
| Over Temperature Hysteresis | OTH | $I_O = 1\text{mA}$ | | 40 | | $^\circ\text{C}$ |
| Power Supply Ripple Rejection | PSRR | $V_{PP} = 200\text{mV}$ | $f = 100\text{Hz}$ | | 65 | dB |
| | | | $f = 1\text{kHz}$ | | 60 | |
| EN Bias Current | I_{EN} | $V_{EN} = V_{CTRL} = 5\text{V}$ | | 5 | | μA |
| EN Input High Threshold | V_{IH} | $V_{IN} = 2.5\text{V to } 5\text{V}$ | 1.5 | | | V |
| EN Input Low Threshold | V_{IL} | $V_{IN} = 2.5\text{V to } 5\text{V}$ | | | 0.3 | V |
| POK Threshold Voltage | V_{TH_OK} | V_{REF} Rising | 90 | | 94 | % |
| POK Hysteresis | | | 3 | 10 | | % |
| POK Pull_Low Voltage | | POK sinks 5mA Current | | 0.2 | 0.4 | V |
| POK Delay Time | T_{DELAY} | From $V_{REF} = V_{TY_OK}$ to rising edge of the V_{POK} | 1 | 2 | 4 | mS |

 Notes: 1. Output current is limited by P_D , maximum $I_O = P_D / (V_{IN(MAX)} - V_O)$.

Typical Performance Characteristics (@ $T_A = +25^\circ\text{C}$, $C_{IN} = C_O = 10\mu\text{F}$, unless otherwise specified.)

1. Load Transient Response

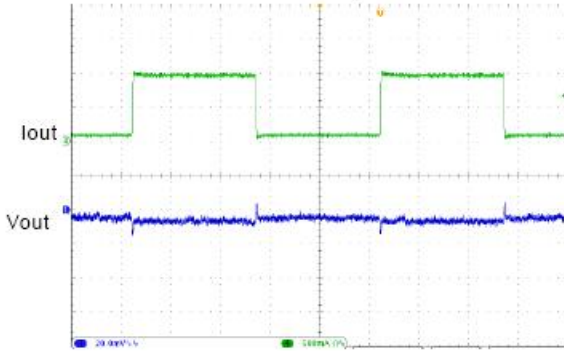

$V_{ctrl}=5\text{V}, V_{in}=1.8\text{V}, V_o=1.2\text{V}, I_o=0.1\sim 1\text{A}$

2. Load Transient Response

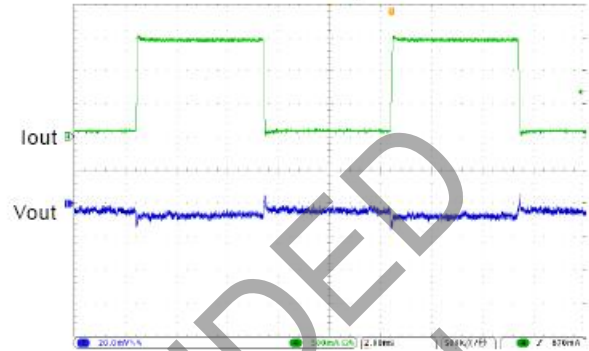

$V_{ctrl}=5\text{V}, V_{in}=1.8\text{V}, V_o=1.2\text{V}, I_o=0.1\sim 1.5\text{A}$

3. Line Transient Response

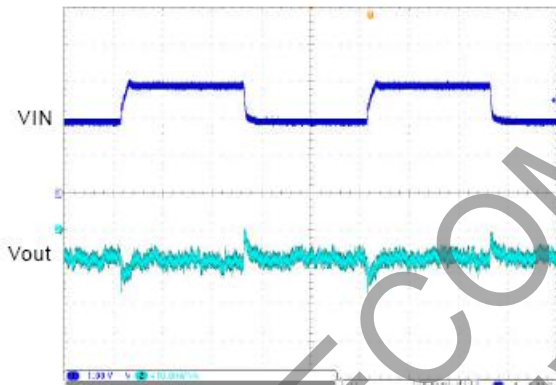

$V_{ctrl}=5\text{V}, V_{in}=2\sim 3\text{V}, V_o=1.2\text{V}, I_o=100\text{mA}$

4. Line Transient Response

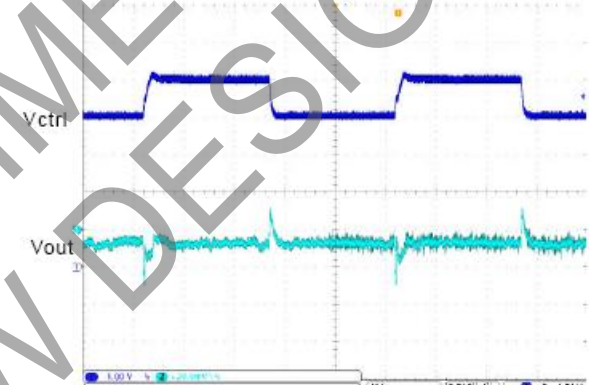

$V_{ctrl}=4\sim 5\text{V}, V_{in}=2\text{V}, V_o=1.2\text{V}, I_o=100\text{mA}$

5. Start Up from VIN

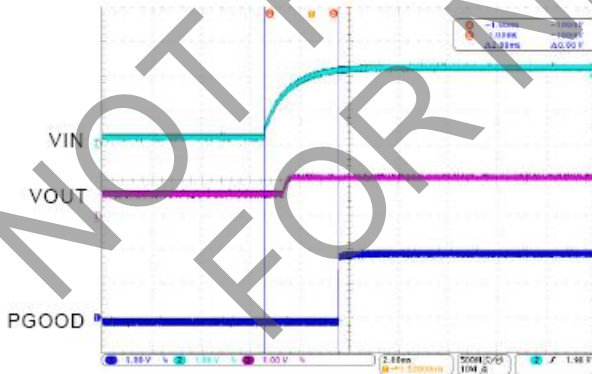

$V_{ctrl}=5\text{V}, V_{in}=2\text{V}, V_o=1.2\text{V}, I_o=1.5\text{A}$

6. Start Up from CTRL

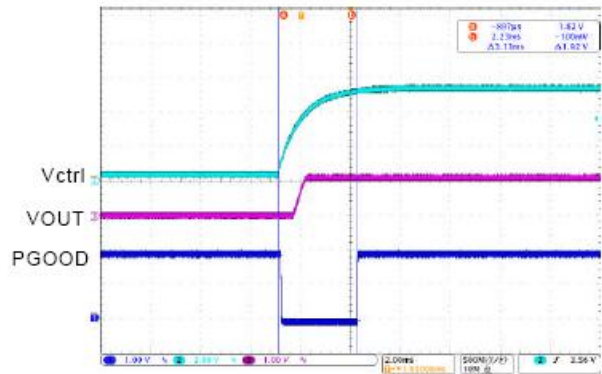

$V_{ctrl}=5\text{V}, V_{in}=2\text{V}, V_o=1.2\text{V}, I_o=1.5\text{A}$

Typical Performance Characteristics (cont.) (@ $T_A = +25^\circ\text{C}$, $C_{IN} = C_O = 10\mu\text{F}$, unless otherwise specified.)

7. Start Up from EN

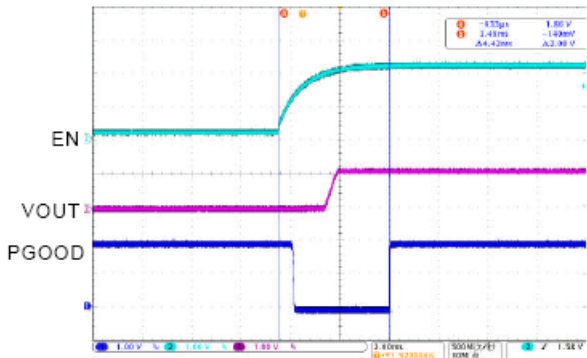

$V_{ctrl}=5\text{V}, V_{in}=2\text{V}, V_{en}=0\sim 2\text{V}, V_o=1.2\text{V}, I_o=1.5\text{A}$

8. Dropout Voltage VS Load Current

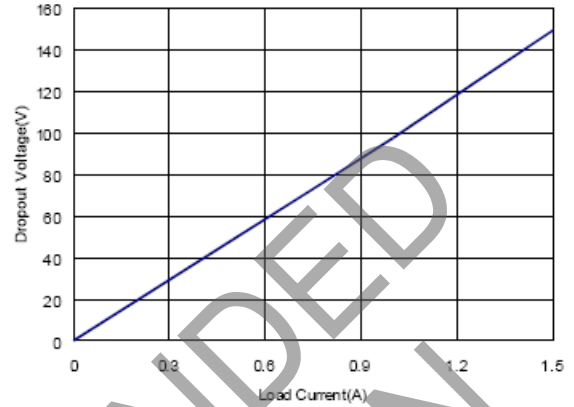

9. Output Voltage VS Load Current

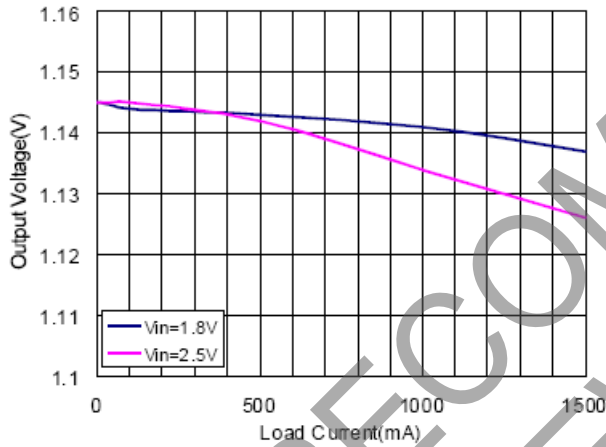

10. Output Voltage VS Temperature

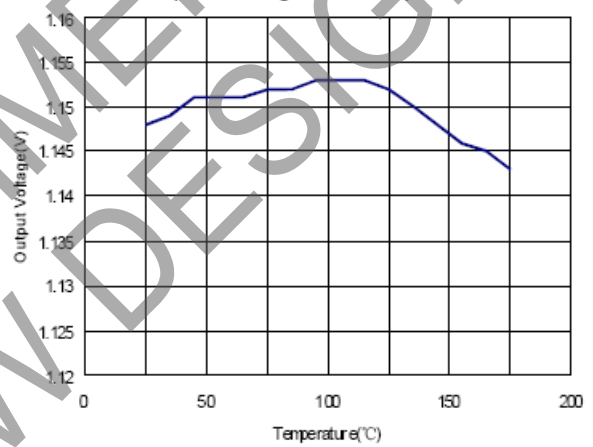

NOT RECOMMENDED FOR NEW DESIGN

Application Information

Capacitor Selection and Regulator Stability

Similar to any low dropout regulator, the external capacitors used with the PAM3108 must be carefully selected for regulator stability and performance.

A capacitor C_{IN} of more than $10\mu F$ can be employed in the input pin, while there is no upper limit for the capacitance of C_{IN} . Please note that the distance between C_{IN} and the input pin of the PAM3108 should not exceed 0.5 inch. Ceramic capacitors are suitable for the PAM3108. Capacitors with larger values and lower ESR (equivalent series resistance) provide better PSRR and line-transient response.

The PAM3108 is designed specifically to work with low ESR ceramic output capacitors in order to save space and improve performance. Using an output ceramic capacitor whose value is $>10\mu F$ with $ESR < 5m\Omega$ ensures stability.

Shutdown Input Operation

The PAM3108 is shut down by pulling the EN input low, and is turned on by tying the EN input to CTRL or leaving the EN input floating.

Input-Output (Dropout) Voltage

A regulator's minimum input-output voltage difference (or dropout voltage) determines the lowest usable supply voltage. The PAM3108 has a typical 150mV dropout voltage.

Current Limit and Short Circuit Protection

The PAM3108 features a current limit, which monitors and controls the gate voltage of the pass transistor. The output current can be limited to 3A by regulating the gate voltage. The PAM3108 also has a built-in short circuit current limit.

Thermal Considerations

Thermal protection limits power dissipation in the PAM3108. When the junction temperature exceeds $170^{\circ}C$, the OTP (Over Temperature Protection) starts the thermal shutdown and turns the pass transistor off. The pass transistor resumes operation after the junction temperature drops below $130^{\circ}C$.

For continuous operation, the junction temperature should be maintained below $+125^{\circ}C$. The power dissipation is defined as:

$$P_D = (V_{IN} - V_{OUT}) \cdot I_O + V_{IN} \cdot I_{GND}$$

The maximum power dissipation depends on the thermal resistance of IC package, PCB layout, the rate of surrounding airflow and temperature difference between junction and ambient. The maximum power dissipation can be calculated by the following formula:

$$P_{D(MAX)} = (T_{J(MAX)} - T_A) / \theta_{JA}$$

Where $T_{J(MAX)}$ is the maximum allowable junction temperature $+125^{\circ}C$, T_A is the ambient temperature and θ_{JA} is the thermal resistance from the junction to the ambient.

Ordering Information

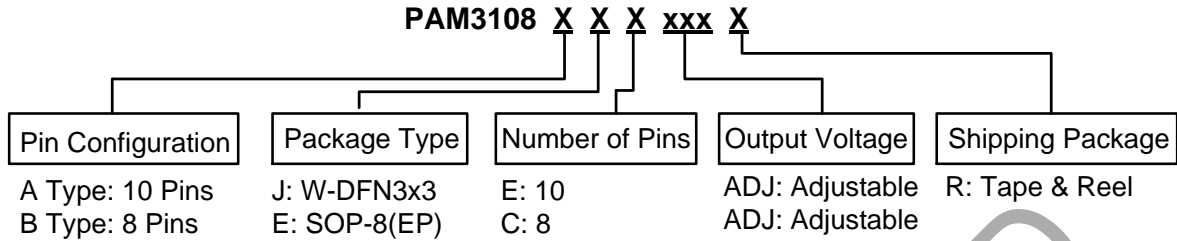

| Part Number | Output Voltage | Package Type | Output Voltage |
|----------------|----------------|--------------|----------------------|
| PAM3108AJEADJR | ADJ | W-DFN3x3-10 | 3000 Units/Tape&Reel |
| PAM3108BECADJR | ADJ | SOP-8(EP) | 2500 Units/Tape&Reel |

Marking Information

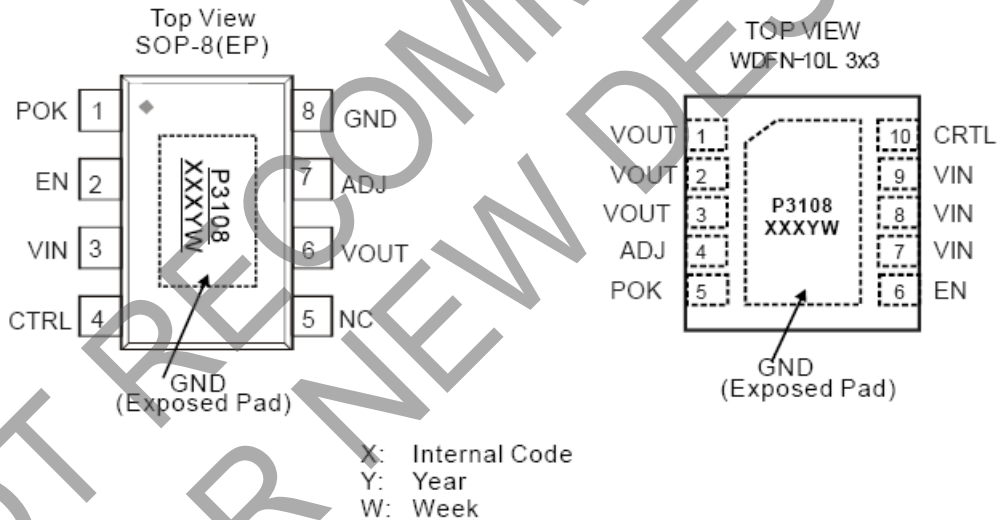

Package Outline Dimensions (All dimensions in mm.)

SOP-8(EP)

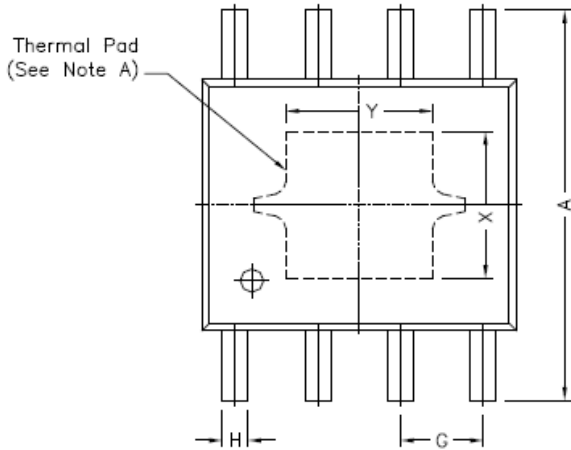

| REF. | DIMENSIONS | |
|---------|-------------|------|
| | Millimeters | |
| | Min. | Max. |
| A | 5.80 | 6.20 |
| B | 4.80 | 5.00 |
| C | 3.80 | 4.00 |
| D | 0 | 8° |
| E | 0.40 | 0.90 |
| F | 0.19 | 0.25 |
| M | 0 | 0.15 |
| H | 0.35 | 0.49 |
| L | 1.35 | 1.75 |
| G | 1.27 TYP. | |
| Option1 | X | 2.28 |
| | Y | 2.28 |
| Option2 | X | 2.41 |
| | Y | 3.30 |

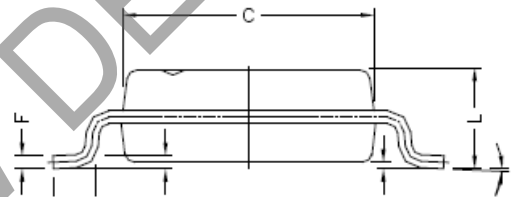
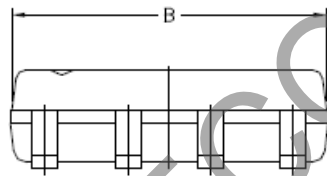

NOT RECOMMENDED FOR NEW DESIGN

Package Outline Dimensions (cont.) (All dimensions in mm.)

W-DFN3x3-10

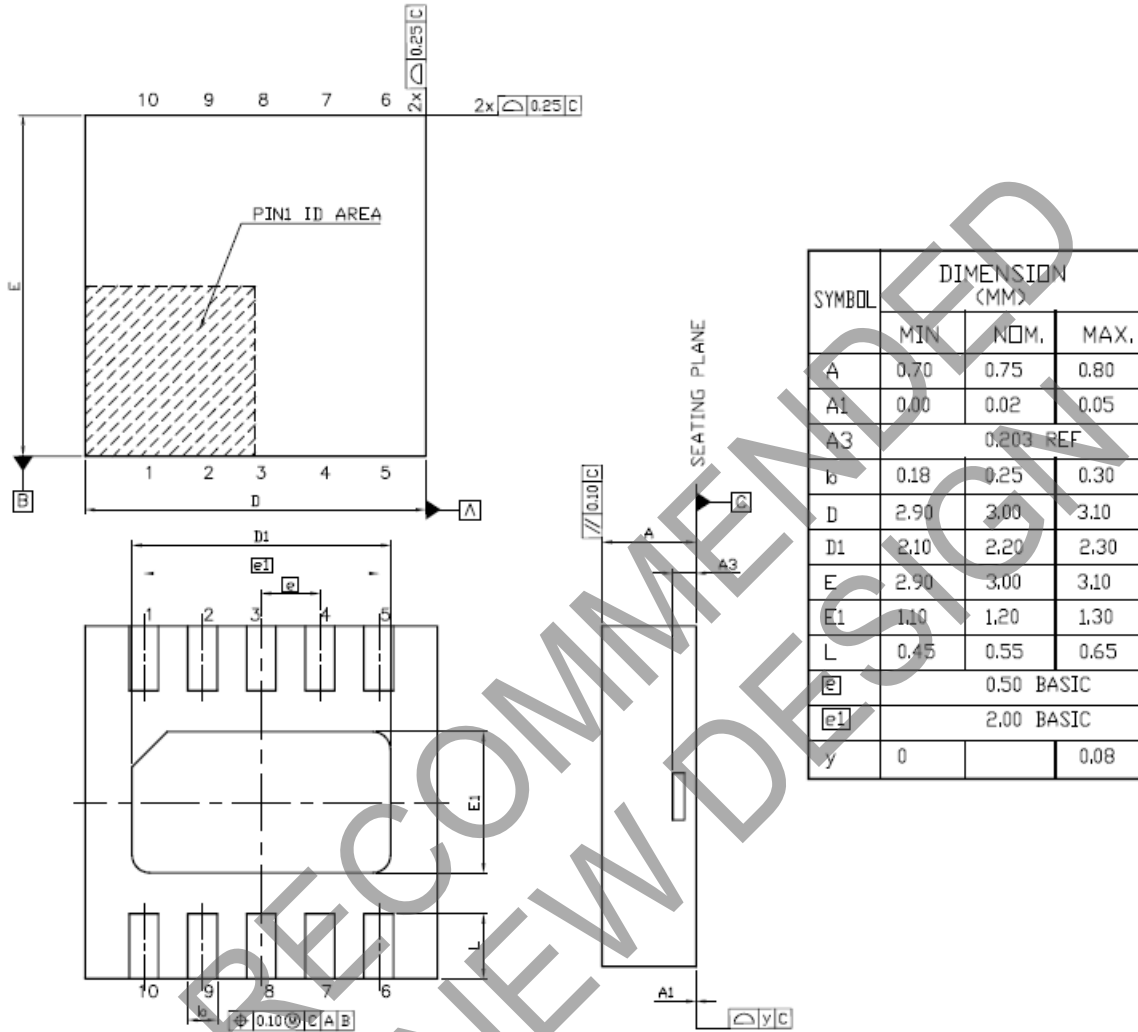

NOT FOR NEW DESIGN

IMPORTANT NOTICE

DIODES INCORPORATED MAKES NO WARRANTY OF ANY KIND, EXPRESS OR IMPLIED, WITH REGARDS TO THIS DOCUMENT, INCLUDING, BUT NOT LIMITED TO, THE IMPLIED WARRANTIES OF MERCHANTABILITY AND FITNESS FOR A PARTICULAR PURPOSE (AND THEIR EQUIVALENTS UNDER THE LAWS OF ANY JURISDICTION).

Diodes Incorporated and its subsidiaries reserve the right to make modifications, enhancements, improvements, corrections or other changes without further notice to this document and any product described herein. Diodes Incorporated does not assume any liability arising out of the application or use of this document or any product described herein; neither does Diodes Incorporated convey any license under its patent or trademark rights, nor the rights of others. Any Customer or user of this document or products described herein in such applications shall assume all risks of such use and will agree to hold Diodes Incorporated and all the companies whose products are represented on Diodes Incorporated website, harmless against all damages.

Diodes Incorporated does not warrant or accept any liability whatsoever in respect of any products purchased through unauthorized sales channel. Should Customers purchase or use Diodes Incorporated products for any unintended or unauthorized application, Customers shall indemnify and hold Diodes Incorporated and its representatives harmless against all claims, damages, expenses, and attorney fees arising out of, directly or indirectly, any claim of personal injury or death associated with such unintended or unauthorized application.

Products described herein may be covered by one or more United States, international or foreign patents pending. Product names and markings noted herein may also be covered by one or more United States, international or foreign trademarks.

This document is written in English but may be translated into multiple languages for reference. Only the English version of this document is the final and determinative format released by Diodes Incorporated.

LIFE SUPPORT

Diodes Incorporated products are specifically not authorized for use as critical components in life support devices or systems without the express written approval of the Chief Executive Officer of Diodes Incorporated. As used herein:

A. Life support devices or systems are devices or systems which:

1. are intended to implant into the body, or
2. support or sustain life and whose failure to perform when properly used in accordance with instructions for use provided in the labeling can be reasonably expected to result in significant injury to the user.

B. A critical component is any component in a life support device or system whose failure to perform can be reasonably expected to cause the failure of the life support device or to affect its safety or effectiveness.

Customers represent that they have all necessary expertise in the safety and regulatory ramifications of their life support devices or systems, and acknowledge and agree that they are solely responsible for all legal, regulatory and safety-related requirements concerning their products and any use of Diodes Incorporated products in such safety-critical, life support devices or systems, notwithstanding any devices- or systems-related information or support that may be provided by Diodes Incorporated. Further, Customers must fully indemnify Diodes Incorporated and its representatives against any damages arising out of the use of Diodes Incorporated products in such safety-critical, life support devices or systems.

Copyright © 2017, Diodes Incorporated

www.diodes.com