

## PI2EQX510E

**1.8V 5.0Gbps, 1-channel, USB3.0 ReDrive**

### Features

- USB 3.0 compatible
- Full compliancy to USB 3.0 Super Speed standard
- One 5.0Gbps differential signal pairs
- Adjustable Receiver Equalization
- 100Ω Differential CML I/O's
- Pin Configured Output Emphasis Control
- Input signal level detect and squelch function
- Automatic Receiver Detect
- Low Power : ~110mW (typ)
- Auto "Slumber" mode for adaptive power management
- Single Supply Voltage: 1.8V
- Totally Lead-Free & Fully RoHS Compliant (Notes 1 & 2)
- Halogen and Antimony Free. "Green" Device (Note 3)
- For automotive applications requiring specific change control (i.e. parts qualified to AEC-Q100/101/200, PPAP capable, and manufactured in IATF 16949 certified facilities), please [contact us](mailto:contact@diodes.com) or your local Diodes representative.
- <https://www.diodes.com/quality/product-definitions/>
- Packaging: 10-Pin X2QFN 1.6 x 1.6 mm

### Block Diagram

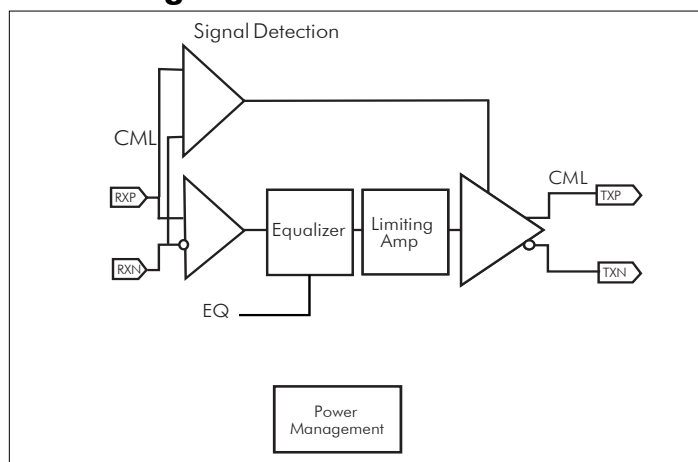

### Description

Diodes' PI2EQX510E is a low power, high performance 5.0 Gbps signal ReDriver™ designed specifically for the USB 3.0 protocol. The device provides programmable equalization and De-Emphasis to optimize performance over a variety of physical mediums by reducing Inter-Symbol Interference.

PI2EQX510E supports one 100Ω Differential CML data I/O's between the Protocol ASIC to a switch fabric, over cable, or to extend the signals across other distant data pathways on the user's platform. The integrated equalization circuitry provides flexibility with signal integrity of the signal before the ReDriver. A low-level input signal detection and output squelch function is provided. The channels' input signal level determines whether the output is active.

The PI2EQX510E also includes a receiver detect function. The receiver detection loop will be active again if the corresponding channel's signal detector is idle for longer than 7.3mS. The channel will then move to Unplug Mode if load not detected, or it will return to Low Power Mode (Slumber Mode) due to inactivity.

**Figure 1**

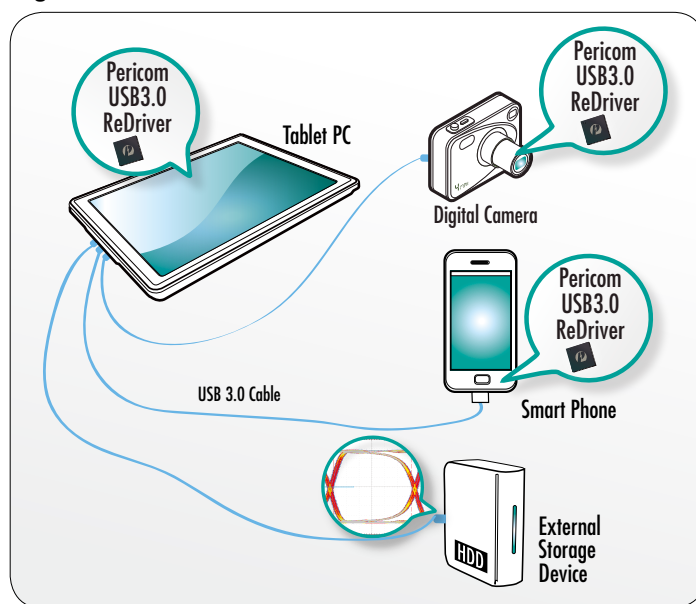

#### Notes:

1. No purposely added lead. Fully EU Directive 2002/95/EC (RoHS), 2011/65/EU (RoHS 2) & 2015/863/EU (RoHS 3) compliant.
2. See <https://www.diodes.com/quality/lead-free/> for more information about Diodes Incorporated's definitions of Halogen- and Antimony-free, "Green" and Lead-free.
3. Halogen- and Antimony-free "Green" products are defined as those which contain <900ppm bromine, <900ppm chlorine (<1500ppm total Br + Cl) and <1000ppm antimony compounds.

*ReDriver is a trademark of Diodes Incorporated.*

PI2EQX510E

Document Number DS42446 Rev 1-3

**Pin Diagram (Top Side View)**

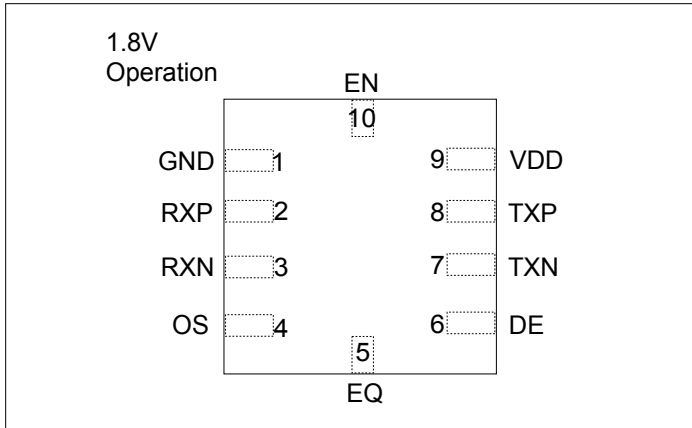

**Pin Description**

Pin #	Pin Name	Type	Description
9	VDD	Power	1.8V power supply
2, 3	RXP, RXN	Input	CML input channels. With Selectable input termination between 50Ω to internal $V_{BIASRX}$ or 60kΩ to GND. The RXP and RXN are pin polarity reversible as long as output pins are reversed at the same time.
5	EQ	Input	Set the equalization of channel. 4-level input pin. With internal 60kΩ pull-up resistor and 120kΩ pull-down resistor.
8, 7	TXP, TXN	Output	Selectable output termination between 50Ω to internal $V_{BIAS}$ , 2kΩ to internal $V_{BIAS}$ or HI-Z. The TXP and TXN are pin reversible as long as input pins are reversed at the same time.
10	EN	Intput	Channel Enable. High = channel Enable, Low = channel disable. With internal 180kΩ pull-up resistor
4	OS	Input	Set output swing of output CML buffer. 3-level input pin. With internal 90kΩ pull-up resistor and 90kΩ pull-down resistor.
6	DE	Input	Set de-emphasis of output CML buffer. 3-level input pin. With internal 90kΩ pull-up resistor and 90kΩ pull-down resistor.
1	GND	GND	Supply Ground.

## Power Management

Notebooks, netbooks, tablets and other power sensitive consumer devices require judicious use of power in order to maximize battery life. In order to minimize the power consumption of our devices, Diodes has added an additional adaptive power management feature. When a signal detector is idle for longer than 1.3ms, the channel will move to low power mode.

In the low power mode, the signal detector will still be monitoring the input channel. If a channel is in low power mode and the input signal is detected, it will wake-up immediately. If a channel is in low power mode and the signal detector is idle longer than 6ms, the receiver detection loop will be active again. If load is not detected, then the Channel will move to Device Unplug Mode and monitor the load continuously. If load is detected, it will return to Low Power Mode and receiver detection will be active again per 6ms.

## Configuration Table

Mode	Input R	Output R
Unplug mode	60k $\Omega$ to GND	2k $\Omega$ to V <sub>BIAS</sub>
Slumber mode	50 $\Omega$ to V <sub>BIAS</sub> R <sub>X</sub>	2k $\Omega$ to V <sub>BIAS</sub>
Active mode	50 $\Omega$ to V <sub>BIAS</sub> R <sub>X</sub>	50 $\Omega$ to V <sub>BIAS</sub>
PD Mode	60k $\Omega$ to GND	HIZ

## Mode Adjustment

### Equalization Setting:

EQ is the selection pin for the equalization.

Equalizer setting	
EQ	@ 2.5GHz
0 (Tie 0 $\Omega$ to GND)	3 dB
Open (Leave open)	6dB (Default)
1 (Tie 0 $\Omega$ to Vdd)	9dB
R (Tie 40k $\Omega$ to GND)	12dB

### De-emphasis Setting:

DE is the selection pin for the de-emphasis.

Output de-emphasis setting	
DE	De-emphasis
0	0 dB
Open	-3.5 dB (default)
1	-6 dB

### Output Swing Setting:

OS is the selection pin for the output swing.

Output swing setting	
OS	Output swing
0	700 mVppd
Open	1000 mVppd (default)
1	1200 mVppd

**PI2EQX510E**

### Maximum Ratings

(Above which useful life may be impaired. For user guidelines, not tested.)

Storage Temperature.....	-65°C to +150°C
Supply Voltage to Ground Potential.....	-0.5V to +2.5V
DC SIG Voltage.....	-0.5V to V <sub>DD</sub> +0.5V
Current Output .....	-25mA to +25mA
Power Dissipation Continuous .....	1.0W
Operating Temperature.....	0°C to +70°C
ESD, Human Body Model.....	-8kv to +8kV

**Note:**

Stresses greater than those listed under MAXIMUM RATINGS may cause permanent damage to the device. This is a stress rating only and functional operation of the device at these or any other conditions above those indicated in the operational sections of this specification is not implied. Exposure to absolute maximum rating conditions for extended periods may affect reliability.

### Recommended Operating Conditions

V<sub>DD</sub> = 1.8V ± 0.2V, T<sub>A</sub> = 0 to 70°C

Symbol	Parameter	Conditions	Min.	Typ.	Max.	Units
<b>Device Parameters</b>						
maximum data rate					5	Gbps
T <sub>power-on-rst</sub>	Power-On Reset Time	Reset time is required after EN pin goes from Low to High			50	ms
t <sub>DIS</sub>	Device disable time	Disable time is required after EN pin goes from High to Low		7		ns
<b>2-Level Control Pins (10)</b>						
V <sub>IH</sub>	DC input logic high		V <sub>dd</sub> *0.65			V
V <sub>IL</sub>	DC input logic low				V <sub>dd</sub> *0.35	
I <sub>IH</sub>	Input High Current				20	uA
I <sub>IL</sub>	Input LOW Current		-20			
<b>3-Level Control Pins (4, 6)</b>						
V <sub>IH</sub>	DC input logic "High"		0.92*V <sub>dd</sub>	V <sub>dd</sub>		V
V <sub>IF</sub>	DC input logic "Float"		0.25*V <sub>dd</sub>	0.5*V <sub>dd</sub>	0.75*V <sub>dd</sub>	
V <sub>IL</sub>	DC input logic "Low"			0	0.08* V <sub>dd</sub>	
I <sub>IH</sub>	Input High Current				40	uA
I <sub>IL</sub>	Input LOW Current		-40			
<b>4-Level Control Pins (5)</b>						
V <sub>IH</sub>	DC input logic "High"		0.92*V <sub>dd</sub>	V <sub>dd</sub>		V
V <sub>IF</sub>	DC input logic "Float"		0.59*V <sub>dd</sub>	0.67*V <sub>dd</sub>	0.75*V <sub>dd</sub>	
V <sub>IR</sub>	DC input logic "With Rext to GND"		0.25*V <sub>dd</sub>	0.33*V <sub>dd</sub>	0.41*V <sub>dd</sub>	
V <sub>IL</sub>	DC input logic "Low"			0	0.08*V <sub>dd</sub>	
I <sub>IH</sub>	Input High Current				30	uA
I <sub>IL</sub>	Input LOW Current		-60			
Rext	External resistor connects to GND		38K	40K	42K	Ω

## AC/DC Electrical Characteristics

1.8V Power Supply Characteristics						
Symbol	Parameter	Conditions	Min.	Typ.	Max.	Units
V <sub>DD</sub>	Power Supply Voltage	Voltage Supply	1.6	1.8	2.0	V
P <sub>SLUMBER</sub>	Supply Power Slumber	Device Plugged, No Input Signal		15	26	mW
P <sub>DEVICE_UNPLUG</sub>	Supply Power Device Unplug	Device Unplugged, No Input Signal		2.2		
P <sub>ACTIVE</sub>	Supply Power Active	V <sub>RX-DIFF-P</sub> ≥ V <sub>TH-SD</sub> , DE=1, Device Plugged, OS = Float		112		
P <sub>DISABLE</sub>	Supply Power Disable	Device disabled, EN=Low		25		μW
I <sub>DD-SLUMBER</sub>	Supply Current Slumber	Device Plugged, No Input Signal		8		mA
I <sub>DD-DEVICE_UNPLUG</sub>	Supply Current Device Unplug	Device Unplugged, No Input Signal		1.2		
I <sub>DD-ACTIVE</sub>	Supply Current Active	V <sub>RX-DIFF-P</sub> ≥ V <sub>TH-SD</sub> , DE=1, Device Plugged, OS = Float		62		
I <sub>DD-DISABLE</sub>	Supply Current Disable	Device disabled, EN=Low		12		μA
Receiver AC/DC						
V <sub>RX-DIFFP-P</sub>	Differential Peak-to-Peak Input Voltage	AC coupled differential RX peak to peak signal	175		1200	mVppd
V <sub>RX-C</sub>	Common Mode Voltage			1		V
V <sub>cm_ac</sub>	RX AC Common Mode Voltage	Measured at Rx pins with termination enabled			150	mV
Z <sub>diff_RX</sub>	DC differential input impedance		72		120	ohm
Z <sub>DC_RX</sub>	DC Common Mode impedance		18		30	Ω
Z <sub>RX_HIGH_IMP+</sub>	DC Input high impedance	Device in unplug mode RX termination measured with respect to AC GND over 500mV max		67		kΩ
RL <sub>RX-DIFF</sub>	Differential return loss	50 MHz-1.25GHz		23		db
		1.25 GH-2.5 GHz		13		
RL <sub>RX-CM</sub>	Common mode return loss	50 MHz-2.5 GHz		8		db
TH-SD	Signal detect Threshold		65		175	mVppd
Transmitter Output AC/DC (100Ω differential)						
V <sub>TX-DIFFP-P</sub>	Differential Peak-to-peak Output Voltage	V <sub>TX-DIFFP-P</sub> = 2 *   V <sub>TX-D+</sub> - V <sub>TX-D-</sub>	400		1200	mVppd
V <sub>TX-LFPS</sub>	LFPS Differential Peak-to-peak Output Voltage		800		1200	
V <sub>TX-C</sub>	Common-Mode Voltage	V <sub>TX-D+</sub> + V <sub>TX-D-</sub>   / 2	0.5		1.2	V
V <sub>cm_ac</sub>	TX AC common mode voltage				100	mVpp
DE		DE = 0		0		dB
		DE = NC	-3.0	-3.5	-4.0	
		DE = 1		-6.0		

### AC/DC Electrical Characteristics Cont.

Symbol	Parameter	Conditions	Min.	Typ.	Max.	Units
Z <sub>diff_TX</sub>	DC differential impedance		72		120	Ω
Z <sub>CM_TX</sub>	DC Common Mode impedance		18		30	
RL <sub>diff_TX</sub>	Differential return loss	f = 50MHz-1.25 GHz		12		dB
		f = 1.25 GHz-2.5 GHz		8		
RL <sub>CM_TX</sub>	Common mode return loss	f = 50 MHz-1.25GHz		10		dB
		f = 1.25GHz-2.5GHz		4.5		
I <sub>TX_SC</sub>	TX short circuit current	TX± shorted to GND		26		mA
V	Transmitter DC common-mode voltage V			0.85		V
V <sub>TX_CM_AC_Active</sub>	TX AC common mode voltage active			30	100	mVpp
V <sub>detect</sub>	Voltage change to allow receiver detect	Positive voltage to sense receiver termination			600	mV
t <sub>R,tF</sub>	Output rise/fall time	20%-80% of differential voltage measured 1" from the output pin		90		ps
T <sub>diff_LH</sub> , T <sub>diff_HL</sub>	Differential propagation delay	Propagation delay between 50% level at input and output		305		ps
<b>Jitter Profile</b>						
T <sub>TX-EYE</sub> <sup>(1)(2)</sup>	Total jitter(Tj)	With 36 inch of input FR4 trace		0.2	0.5	UI <sup>(3)</sup>
DJ <sub>TX</sub> <sup>(2)</sup>	Deterministic jitter(Dj)			0.1	0.3	
RJ <sub>TX</sub> <sup>(2)(4)</sup>	Random jitter(Rj)			0.09	0.2	

**Note:**

1. Includes RJ at 10<sup>-12</sup> BER
2. Deterministic jitter measured with PRBS7 pattern, Random jitter measured with 1010 pattern V<sub>RX-DIFFP-P</sub>=1000mVpp, 5Gbps,
3. UI = 200ps
4. Rj calculated as 14.069 times the RMS random jitter for 10<sup>-12</sup> BER

**PI2EQX510E**

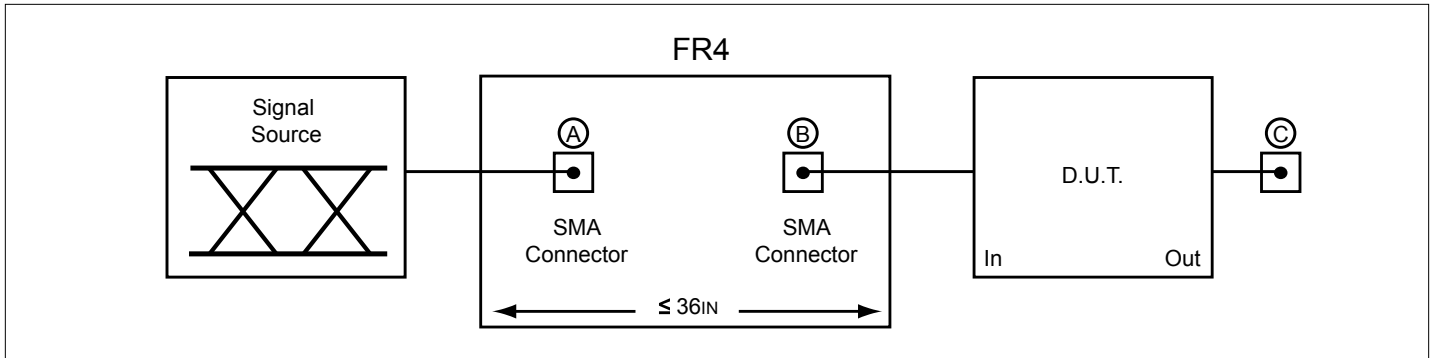

**Test Condition Referenced in the Electrical Characteristic Table**

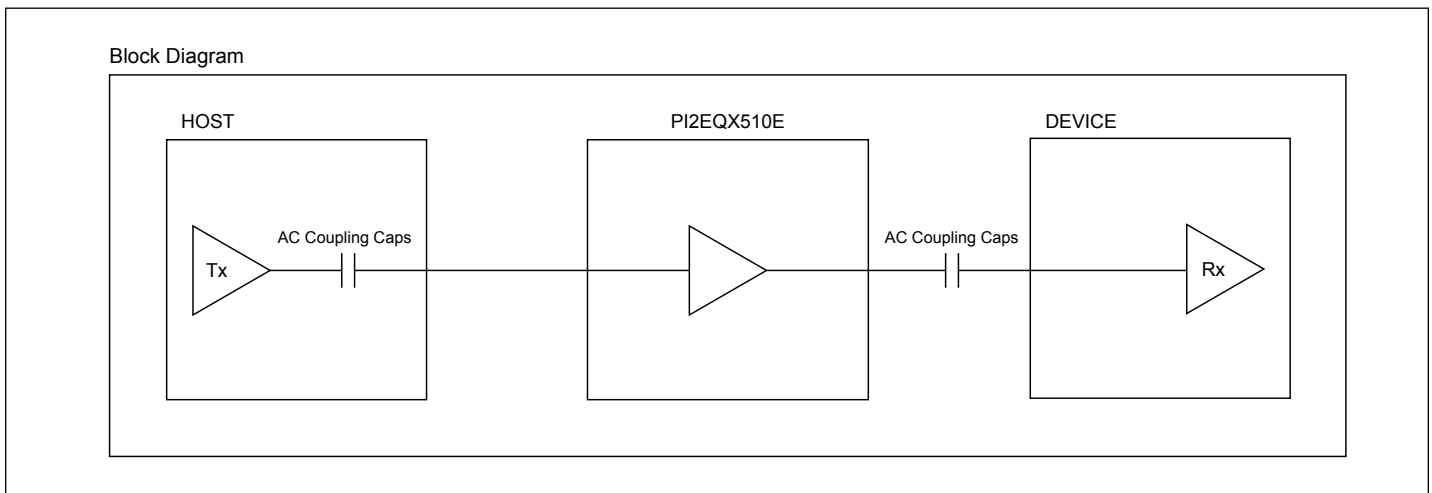

**PI2EQX510E Application Schematics**

**Packaging Mechanical: 10-X2QFN (XUA)**

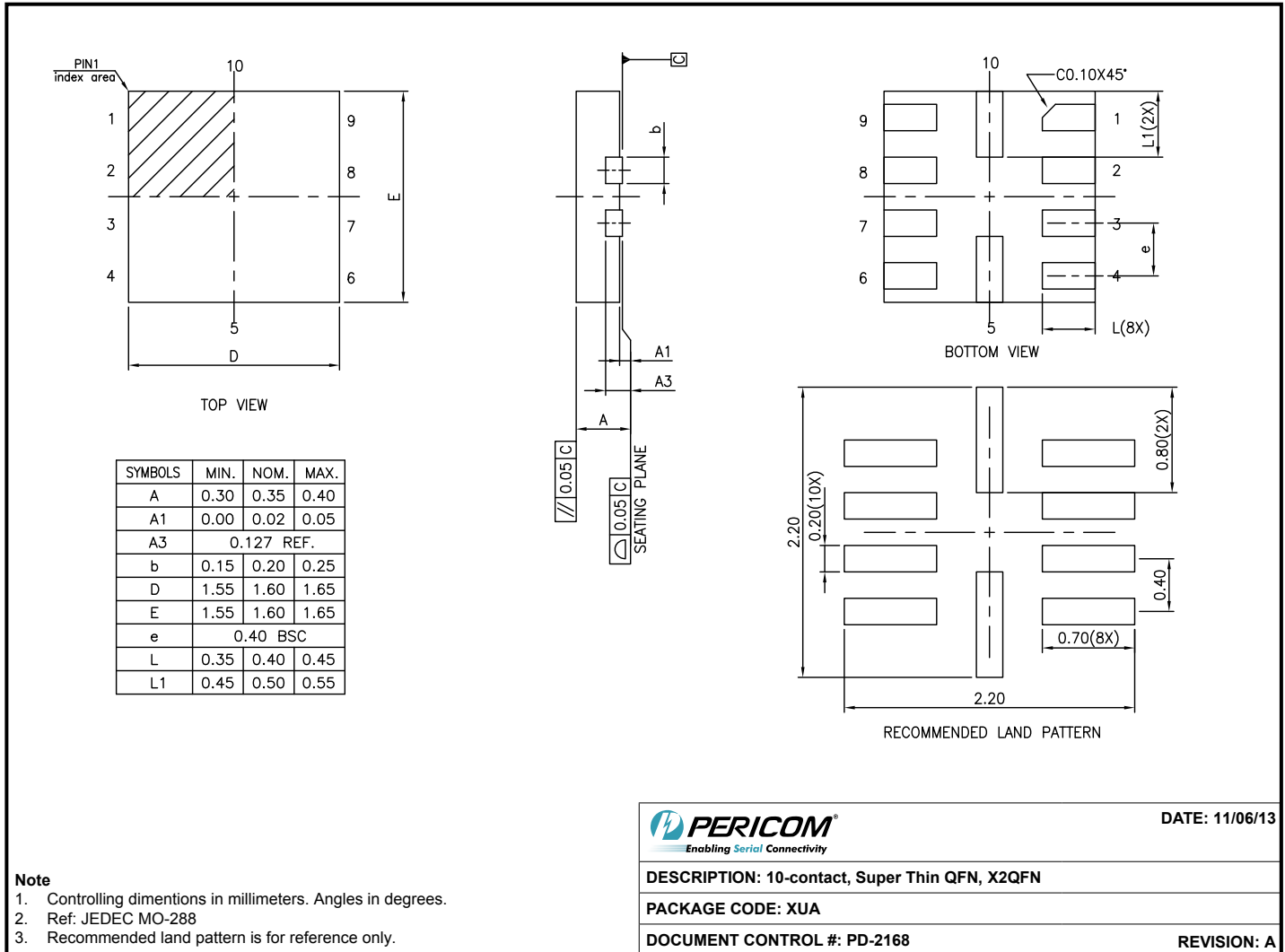

<b>PERICOM</b> Enabling Serial Connectivity	DATE: 11/06/13
<b>DESCRIPTION: 10-contact, Super Thin QFN, X2QFN</b>	
<b>PACKAGE CODE: XUA</b>	
<b>DOCUMENT CONTROL #: PD-2168</b>	<b>REVISION: A</b>

13-0218

**For latest package info.**

please check: <http://www.diodes.com/design/support/packaging/pericom-packaging/packaging-mechanicals-and-thermal-characteristics/>

**Ordering Information**

Ordering Number	Package Code	Package Description
PI2EQX510EXUAEX	XUA	10-contact, Super Thin QFN, X2QFN

**Notes:**

- No purposely added lead. Fully EU Directive 2002/95/EC (RoHS), 2011/65/EU (RoHS 2) & 2015/863/EU (RoHS 3) compliant.
- See <https://www.diodes.com/quality/lead-free/> for more information about Diodes Incorporated's definitions of Halogen- and Antimony-free, "Green" and Lead-free.
- Halogen- and Antimony-free "Green" products are defined as those which contain <900ppm bromine, <900ppm chlorine (<1500ppm total Br + Cl) and <1000ppm antimony compounds.
- E = Pb-free and Green
- X suffix = Tape/Reel



**IMPORTANT NOTICE**

DIODES INCORPORATED MAKES NO WARRANTY OF ANY KIND, EXPRESS OR IMPLIED, WITH REGARDS TO THIS DOCUMENT, INCLUDING, BUT NOT LIMITED TO, THE IMPLIED WARRANTIES OF MERCHANTABILITY AND FITNESS FOR A PARTICULAR PURPOSE (AND THEIR EQUIVALENTS UNDER THE LAWS OF ANY JURISDICTION).

Diodes Incorporated and its subsidiaries reserve the right to make modifications, enhancements, improvements, corrections or other changes without further notice to this document and any product described herein. Diodes Incorporated does not assume any liability arising out of the application or use of this document or any product described herein; neither does Diodes Incorporated convey any license under its patent or trademark rights, nor the rights of others. Any Customer or user of this document or products described herein in such applications shall assume all risks of such use and will agree to hold Diodes Incorporated and all the companies whose products are represented on Diodes Incorporated website, harmless against all damages.

Diodes Incorporated does not warrant or accept any liability whatsoever in respect of any products purchased through unauthorized sales channel.

Should Customers purchase or use Diodes Incorporated products for any unintended or unauthorized application, Customers shall indemnify and hold Diodes Incorporated and its representatives harmless against all claims, damages, expenses, and attorney fees arising out of, directly or indirectly, any claim of personal injury or death associated with such unintended or unauthorized application.

Products described herein may be covered by one or more United States, international or foreign patents pending. Product names and markings noted herein may also be covered by one or more United States, international or foreign trademarks.

This document is written in English but may be translated into multiple languages for reference. Only the English version of this document is the final and definitive format released by Diodes Incorporated.

**LIFE SUPPORT**

Diodes Incorporated products are specifically not authorized for use as critical components in life support devices or systems without the express written approval of the Chief Executive Officer of Diodes Incorporated. As used herein:

A. Life support devices or systems are devices or systems which:

1. are intended to implant into the body, or

2. support or sustain life and whose failure to perform when properly used in accordance with instructions for use provided in the labeling can be reasonably expected to result in significant injury to the user.

B. A critical component is any component in a life support device or system whose failure to perform can be reasonably expected to cause the failure of the life support device or to affect its safety or effectiveness.

Customers represent that they have all necessary expertise in the safety and regulatory ramifications of their life support devices or systems, and acknowledge and agree that they are solely responsible for all legal, regulatory and safety-related requirements concerning their products and any use of Diodes Incorporated products in such safety-critical, life support devices or systems, notwithstanding any devices- or systems-related information or support that may be provided by Diodes Incorporated. Further, Customers must fully indemnify Diodes Incorporated and its representatives against any damages arising out of the use of Diodes Incorporated products in such safety-critical, life support devices or systems.

Copyright © 2016, Diodes Incorporated

[www.diodes.com](http://www.diodes.com)