

6.5Gbps, 1-port, 1.5V/3.3V SATA/SAS ReDriver™ with Analog/Digital Configuration

Features

- Two 6.5Gbps differential channels
- Output swing up to 1.2V pk-to-pk
- SAS, SATA fully supported
- Adjustable Receiver Equalization - 0 to 16 dB
- 100Ω Differential CML I/O's
- Continuous step output swing adjustment
- Continuous step output pre-emphasis control
- Input signal level detect and squelch for each channel
- OOB fully supported
- Auto HDD Rate Detection for out swing/emphasis setting
- Supply Voltage: 1.5V or 3.3V
- Low Power, 162mW @ 1.5V (600 mV Swing)
- Stand-by Mode – Power Down State: Current < 56 μA
- Auto Slumber Mode power: 22.5mW typical
- Industrial Temperature Range -40 to 85°C
- Packaging: 20-contact TQFN (4x4mm)

Applications

- Server
- Desktop
- Data Storage/Workstation

Block Diagram

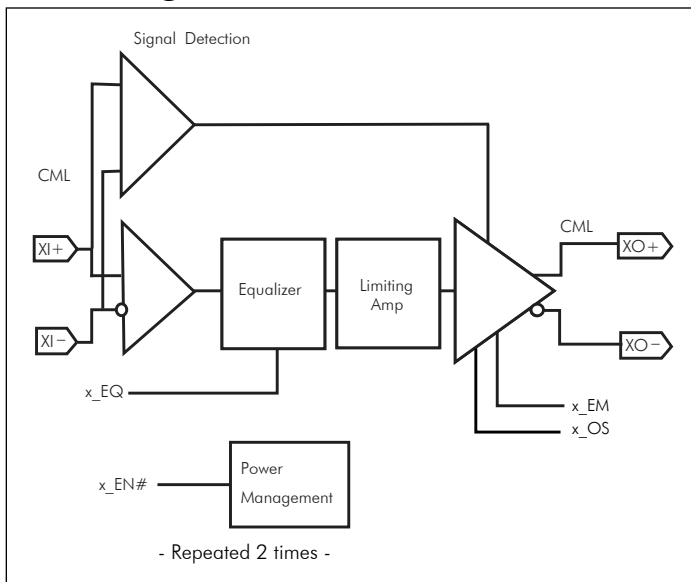

Description

The PI3EQX6801A is a low power, 1.5V/3.3V, 6.5Gbps, SATA/SAS signal ReDriver™. The device provides programmable equalization, to optimize performance over a variety of physical mediums by reducing Inter-Symbol Interference.

PI3EQX6801A supports two 100Ω Differential CML data I/O's between the Protocol ASIC to a switch fabric, across a backplane, or to extend the signals across other distant data pathways on the user's platform.

The integrated equalization circuitry provides flexibility with signal integrity of the signal before the ReDriver.

A low-level input signal detection and output squelch function is provided for each channel. Each channel operates fully independently. When the channels are enabled (x_EN#=0) and operating, that channels input signal level (on xI+/-) determines whether the output is active. If the input signal level of the channel falls below the active threshold level (Vth-) then the outputs are driven to the common mode voltage.

Each lane can be powered-down if x_EN# =1, and when A_EN# and B_EN# are both high, the device enters a low power standby mode.

Pin Diagram (Top Side View)

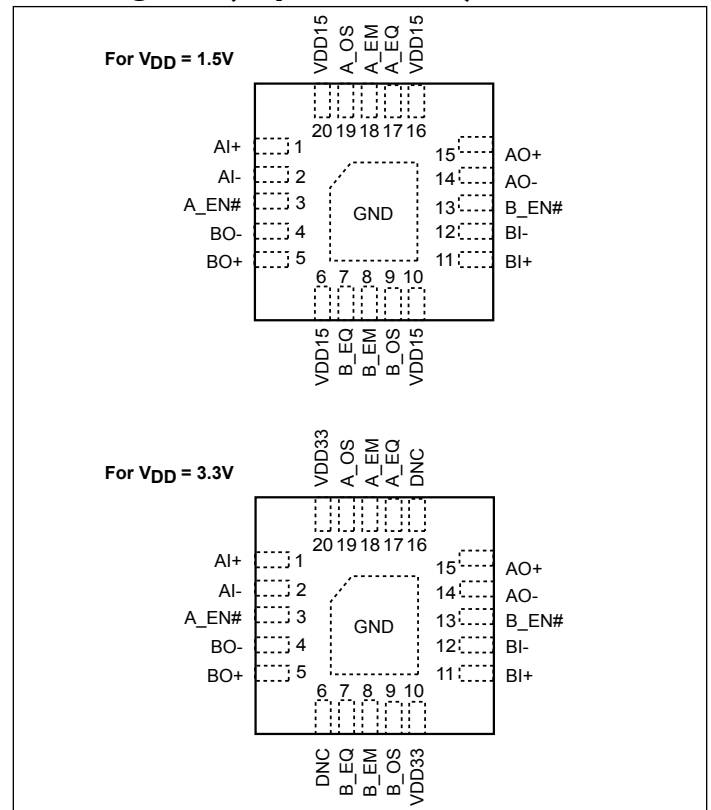

Pin Description

3.3V Supply	1.5V Supply	Pin Name	Type	Description
18	18	A_EM	Input	Output emphasis adjustment for Channel A. Allows analog resistive adjustment of emphasis. (See configuration tables.)
3	3	A_EN#	Input	Channel A Enable. Low is normal operation. High is power down mode. With internal 200K Ω pull-down resistor.
17	17	A_EQ	Input	Equalization adjustment. (See Configuration table.) (Tri-level)
19	19	A_OS	Input	Channel A output swing adjustment. Allows analog resistive adjustment of output swing level. (See configuration tables.)
1 2	1 2	AI+ AI-	Input	CML input forward channel A with internal 50 Ω pull-up resistors connected to V _{BIAS} (100 Ω differential).
15 14	15 14	AO+ AO-	Output	CML output channel A with internal 50 Ω pull-up resistors connected to V _{BIAS} (100 Ω differential).
8	8	B_EM	Input	Output emphasis adjustment for channel B. Allows analog resistive adjustment of output emphasis. (See configuration tables.)
13	13	B_EN#	Input	Channel B Enable. Low is normal operation. High is power down mode. With internal 200K Ω pull-down resistor.
7	7	B_EQ	Input	Channel B equalization adjustment. (Tri-level)
11 12	11 12	BI+ BI-	Input	CML input return channel B with internal 50 Ω pull-up resistor connected to V _{BIAS} (100 Ω differential).
5 4	5 4	BO+ BO-	Output	Positive CML output channel B with internal 50 Ω pull-up resistor connected to V _{BIAS} (100 Ω differential).
9	9	B_OS	Input	Channel B output swing adjustment. Allows analog resistive adjustment of output swing level. See configuration tables.
6, 16	-	DNC / V _{DD15}	-	Do not connect for 3.3V application, or V _{DD15} for 1.5V application
Center Pad	Center Pad	GND	GND	Supply ground.
-	6, 10, 16, 20	V _{DD15}	Power	Alternate supply voltage, 1.5V
10, 20		V _{DD33} / V _{DD15}	Power	V _{DD33} for 3.3V application, or V _{DD15} for 1.5V application

Receive Equalizer Configuration Table

x_EN#	x_EQ	Input Equalization @ 3.0GHz	Function
1	X	N/A	Channel x disabled. Hi-impedance terminations
0	0	8dB	Channel enabled, medium input equalization
0	1	16dB	Channel enabled, high input equalization
0	V _{DD} /2	4dB (Default)	Channel enabled, low input equalization

Output Swing Adjustment ⁽¹⁾

R[A:B]_OS (Ω)	Output Swing, mV (V _{TX-DIFF-p}) ⁽²⁾	
	3Gbps	6Gbps
5.5K	450	600
5K	490	660
4.5K	540	730
4K	600	820
3.5K	670	910
3K	760	1,000
2.5K	870	1,080
2K	990	1,200

Note:

1. Suggested initial test values. Exact resistor values will vary depending on PCB design.
2. Auto HDD Rate Detection is ON.

Output Emphasis Adjustment ^(1,2)

R[A:B]_EM (Ω)	Pre-emphasis
Do Not Connect	0dB
14K	+2.0dB
10K	+3.0dB
6K	+4.0dB
2K	+6.0dB

Note:

1. Suggested initial test values. Exact resistor values will vary depending on PCB design.
2. Referenced to output swing of 600mV, will vary as a function of swing, increasing as swing decreases.

Note:

V_{MAX} of output can not exceed 1,200mVppd (i.e. V_{DIFF-PRE} can not exceed 1,200mV)

Maximum Ratings

(Above which useful life may be impaired. For user guidelines, not tested.)

Storage Temperature.....	-65°C to +150°C
Supply Voltage to Ground Potential (V _{DD33}).....	-0.5V to +4.5V
Supply Voltage to Ground Potential (V _{DD15}).....	-0.5V to +2.5V
DC SIG Voltage.....	-0.5V to V _{DD} +0.5V
Current Output	-25mA to +25mA
Power Dissipation Continuous	1W
Junction Temperature (T _j).....	125°C
ESD, Human Body Model.....	-7kV to +7kV

Note:
Stresses greater than those listed under MAXIMUM RATINGS may cause permanent damage to the device. This is a stress rating only and functional operation of the device at these or any other conditions above those indicated in the operational sections of this specification is not implied. Exposure to absolute maximum rating conditions for extended periods may affect reliability.

AC/DC Electrical Characteristics

Symbol	Parameter	Conditions	Min.	Typ.	Max.	Units
I _{DD-STANDBY1}	Standby Supply Current , 1.5V or 3.3V	[A:B]_EN#=1			0.056	mA
I _{DD-ACTIVE1}	Active Supply Current, 1.5 or 3.3V	x_EN# = 0, Output 600mV _{pp} , 0dB pre-emph		108		
1.5V Power Characteristics⁽¹⁾						
V _{DD15}	Power Supply Voltage		1.425		1.575	V
P _{STANDBY15}	Standby Supply Power, 1.5V	[A:B]_EN#=1			0.089	mW
P _{ACTIVE15}	Active Supply Power, 1.5V	x_EN# = 0, Output 600mV _{pp} , 0dB pre-emph		162		
P _{SLUMBER}	Supply Power Slumber			22.5		
3.3V Power Characteristics⁽¹⁾						
V _{DD33}	Power Supply Voltage		3		3.6	V
P _{STANDBY33}	Standby Supply Power, 3.3V	[A:B]_EN#=1			1.82	mW
P _{ACTIVE33}	Active Supply Power, 3.3V	x_EN# = 0, Output 600mV _{pp} , 0dB pre-emph		356		
P _{SLUMBER}	Supply Power Slumber, 3.3V			50		

Note:

- This device can operate from either 1.2V or 3.3V power supply. Note these different device pins are used for the different supply voltages. Performance characteristics are the same at either operating voltage.

AC/DC Electrical Characteristics

CML Transmitter Output

Symbol	Parameter	Conditions	Min.	Typ.	Max.	Units
Z _{TX-DIFF-DC}	DC Differential TX Impedance		85	100	115	Ω
V _{TX-DIFFP-P}	Differential Peak-to-peak Output Voltage	$V_{TX-DIFFP-P} = 2 * V_{TX-D+} - V_{TX-D-} $	400		1200	mV
V _{TX-C}	Common-Mode Voltage	$ V_{TX-D+} + V_{TX-D-} /2$	0		2	V
t _F , t _R	Transition Time 20% to 80%		50		150	ps
V _{amp_bal}	TX amplitude imbalance	@3Gbps			10	%
T _{skew}	TX differential skew				20	ps
V _{cm_ac}	TX AC common mode voltage	@3Gbps			30	mVpp
V _{TX-Pre-Ratio-max}	Max TX Pre-emphasis Level				6	dB
S _{dd11_TX}	TX differential mode return loss	75MHz - 300MHz	14			dB
		300MHz - 600MHz	8			
		600MHz - 1.2GHz	6			
		1.2GHz - 2.4GHz	6			
		2.4GHz - 3.0GHz	3			
		3.0 GHz - 6.5GHz	1			
S _{cc11_TX}	TX common mode return loss	150MHz - 300MHz	8			dB
		300MHz - 600MHz	5			
		600MHz - 1.2GHz	2			
		1.2GHz - 2.4GHz	1			
		2.4GHz - 3.0GHz	1			
		3.0GHz - 5.0GHz	1			
S _{dc11_TX}	TX impedance balance	150MHz - 300MHz	30			dB
		300MHz - 600MHz	30			
		600MHz - 1.2GHz	20			
		1.2GHz - 2.4GHz	10			
		2.4GHz - 3.0GHz	10			
		3.0GHz - 5.0GHz	4			

LVC MOS Control Pins

V _{IH}	Input High Voltage (Bi-level)		0.65 × V _{DD}			V
V _{IL}	Input Low Voltage (Bi-level)				0.35 × V _{DD}	
V _{IH}	Input High Voltage (Tri-level)		0.8 × V _{DD}			
V _{IL}	Input Low Voltage (Tri-level)				0.2 × V _{DD}	
I _{IH}	Input High Current				50	μA
I _{IL}	Input Low Current		-50			

AC/DC Electrical Characteristics Cont.

CML Receiver Input

Symbol	Parameter	Conditions	Min.	Typ.	Max.	Units
Z _{RX-DC}	DC Input Impedance		40			Ω
Z _{RX-DIFF-DC}	DC Differential Input Impedance		85	100	115	
V _{RX-DIFFP-P}	Differential Input Peak-to-peak Voltage		240		1000	mV
V _{RX-CM-ACP}	AC Peak Common Mode Input Voltage				100	mV
V _{TH-SD}	OOB Signal detect input Threshold		75		200 ⁽¹⁾	mVppd
S _{cc11_RX}	RX common mode return loss	150MHz - 300MHz 300MHz - 600MHz 600MHz - 1.2GHz 1.2GHz - 2.4GHz 2.4GHz - 3.0GHz 3.0GHz - 5.0GHz	5 5 2 1 1 1			dB
S _{dd11_RX}	RX differential mode return loss	75MHz-300MHz 300MHz - 600MHz 600MHz - 1.2GHz 1.2GHz - 2.4GHz 2.4GHz - 3.0GHz 3.0 GHz - 6.5GHz	18 14 10 8 3 1			dB
S _{dc11_RX}	RX impedance balance	150MHz - 300MHz 300MHz - 600MHz 600MHz - 1.2GHz 1.2GHz - 2.4GHz 2.4GHz - 3.0GHz 3.0GHz - 5.0GHz 5.0GHz - 6.5GHz	30 30 20 10 10 4 4			dB

Equalization

T _J	Total Jitter p-p	Measured at 6Gbps			0.37	UI
D _J	Deterministic Jitter	Measured at 6Gbps			0.19	UI

Note:

1. Using Compliance test at 1.5Gbps and 3Gbps. Also using OOB (OOB is formed by ALIGNp primitive or D24.3) test patterns at 1.5Gbps. The ALIGN primitive (K28.5+D10.2+D27.3 = 0011111010+0101010101+0010011100). The D24.3 = 00110011001100110011

Auto Slumber Mode Entry/Exit Time

Symbol	Parameter	Conditions	Min.	Typ. ⁽¹⁾	Max.	Units
T _{SlumberON}	Entry time to Slumber Mode	Electrical Idle at Input (See Figure)		10	20	μs
T _{SlumberOFF}	Exit time from Slumber Mode	After first signal activity (See Figure)		6	20	ns

Latency

Symbol	Parameter	Conditions	Min.	Typ.	Max.	Units
t _{PD}	Latency			750		ps

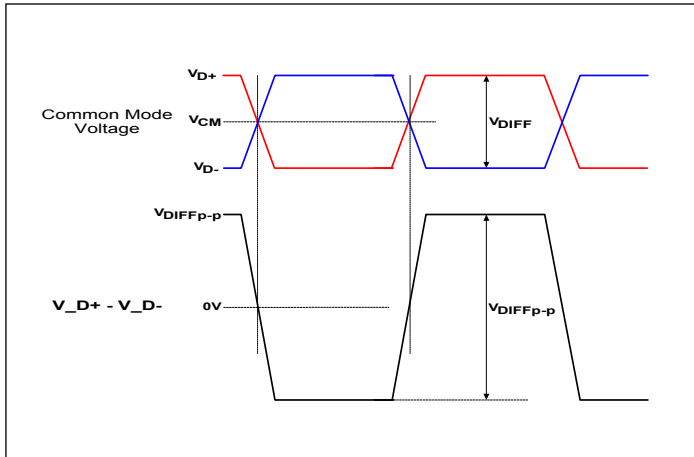

Definition of Differential Voltage and Differential Voltage Peak-to-Peak

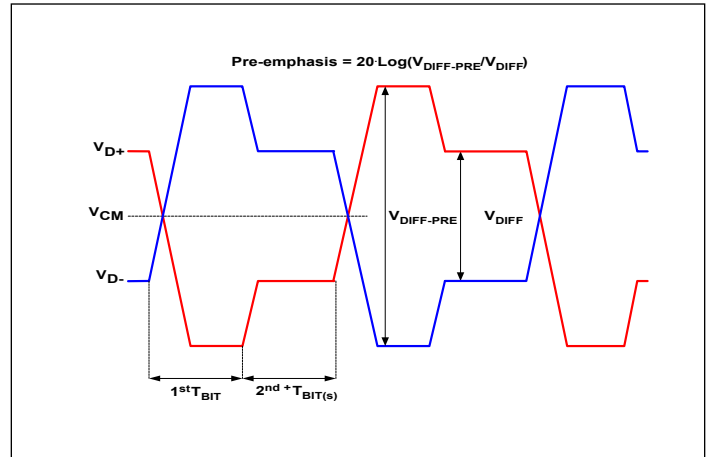

Definition of Pre-emphasis

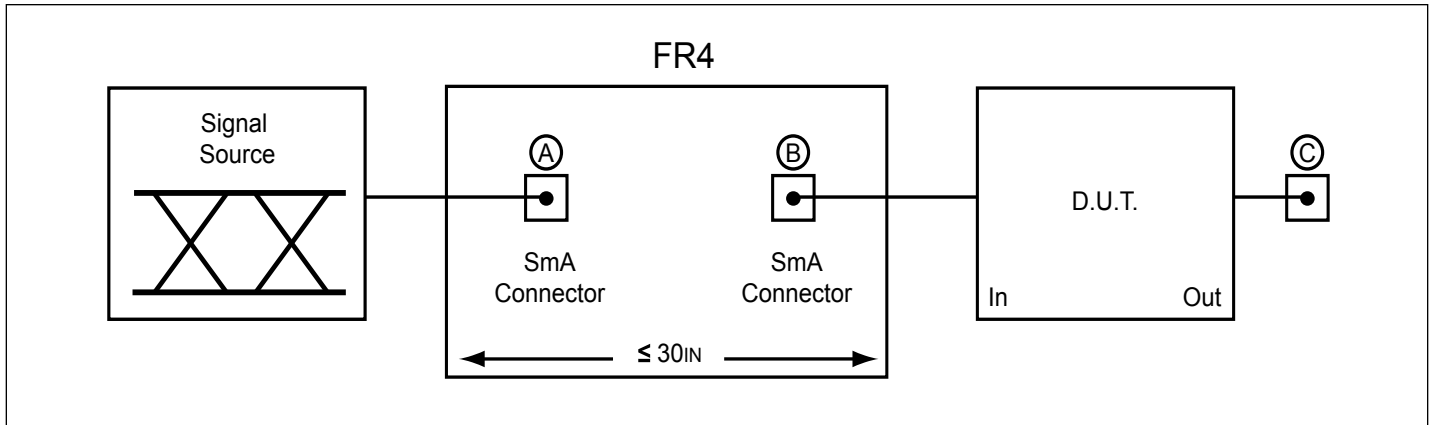

Test Condition Referenced in the Electrical Characteristic Table

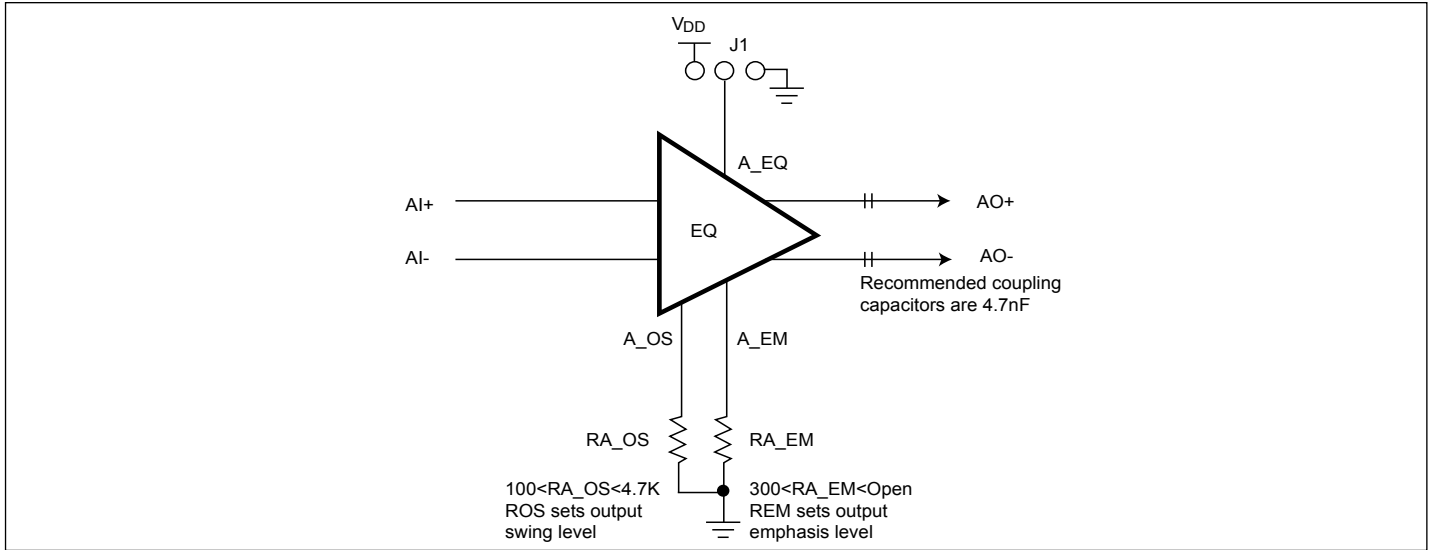

Implementation Diagram

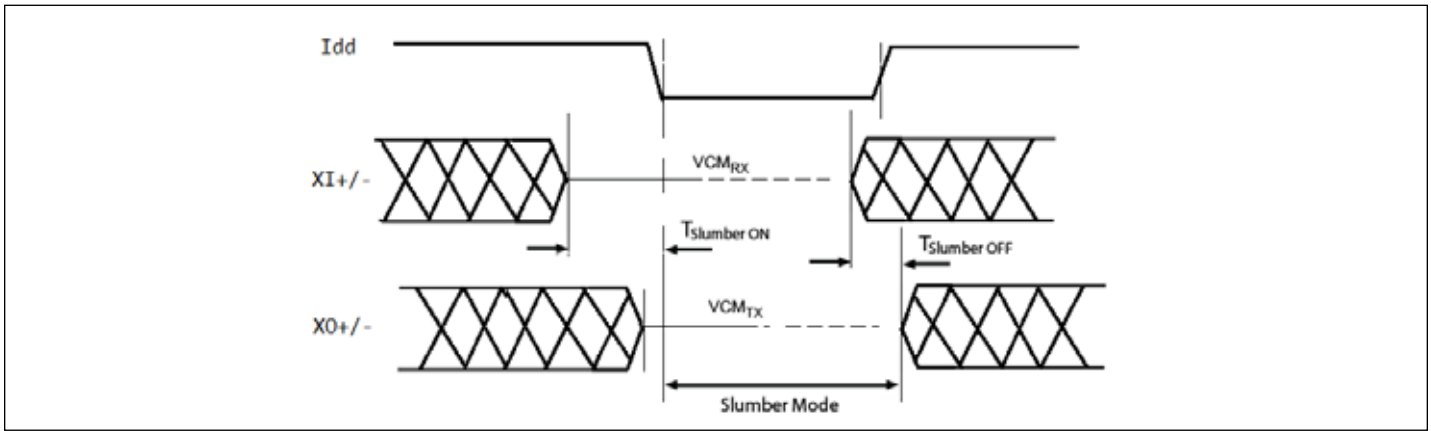

Auto Slumber Mode Entry and Exit Timing

Part Marking

ZD Package

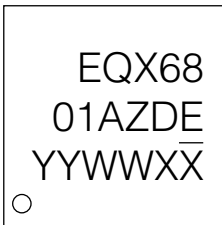

YY: Year

WW: Workweek

1st X: Assembly Code

2nd X: Fab Code

Packaging Mechanical: 20-TQFN (ZD)

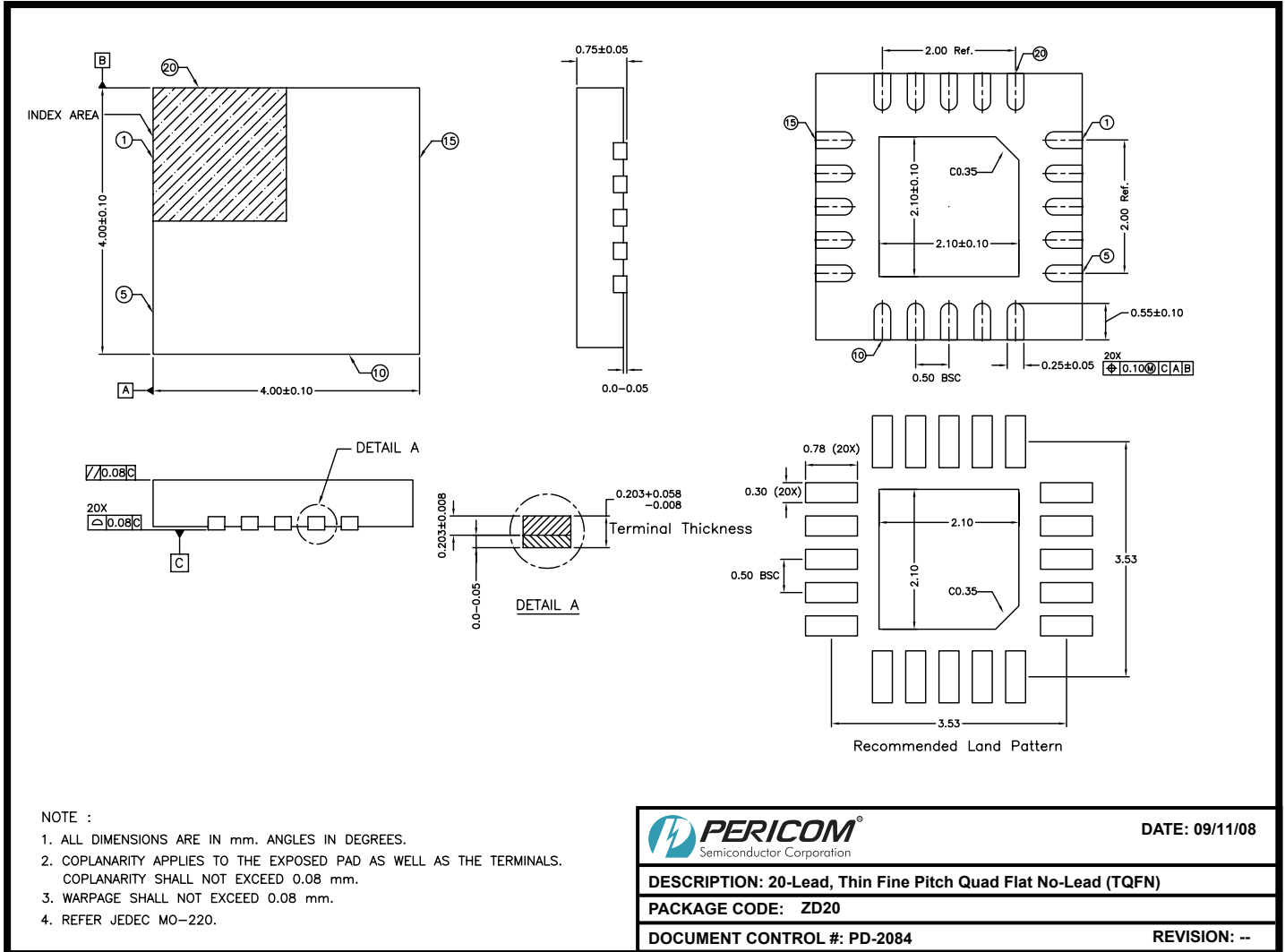

08-0456

For latest package info.

please check: <http://www.diodes.com/design/support/packaging/pericom-packaging/packaging-mechanicals-and-thermal-characteristics/>

Ordering Information

Ordering Number	Package Code	Package Description
PI3EQX6801AZDEX	ZD	20-Lead, Thin Fine Pitch Quad Flat No-Lead (TQFN)

Notes:

1. EU Directive 2002/95/EC (RoHS), 2011/65/EU (RoHS 2) & 2015/863/EU (RoHS 3) compliant. All applicable RoHS exemptions applied.
2. See <http://www.diodes.com/quality/lead-free/> for more information about Diodes Incorporated's definitions of Halogen- and Antimony-free, "Green" and Lead-free. Thermal characteristics can be found on the company web site at www.diodes.com/design/support/packaging/
3. E = Pb-free and Green
4. X suffix = Tape/Reel

IMPORTANT NOTICE

DIODES INCORPORATED MAKES NO WARRANTY OF ANY KIND, EXPRESS OR IMPLIED, WITH REGARDS TO THIS DOCUMENT, INCLUDING, BUT NOT LIMITED TO, THE IMPLIED WARRANTIES OF MERCHANTABILITY AND FITNESS FOR A PARTICULAR PURPOSE (AND THEIR EQUIVALENTS UNDER THE LAWS OF ANY JURISDICTION).

Diodes Incorporated and its subsidiaries reserve the right to make modifications, enhancements, improvements, corrections or other changes without further notice to this document and any product described herein. Diodes Incorporated does not assume any liability arising out of the application or use of this document or any product described herein; neither does Diodes Incorporated convey any license under its patent or trademark rights, nor the rights of others. Any Customer or user of this document or products described herein in such applications shall assume all risks of such use and will agree to hold Diodes Incorporated and all the companies whose products are represented on Diodes Incorporated website, harmless against all damages.

Diodes Incorporated does not warrant or accept any liability whatsoever in respect of any products purchased through unauthorized sales channel.

Should Customers purchase or use Diodes Incorporated products for any unintended or unauthorized application, Customers shall indemnify and hold Diodes Incorporated and its representatives harmless against all claims, damages, expenses, and attorney fees arising out of, directly or indirectly, any claim of personal injury or death associated with such unintended or unauthorized application.

Products described herein may be covered by one or more United States, international or foreign patents pending. Product names and markings noted herein may also be covered by one or more United States, international or foreign trademarks.

This document is written in English but may be translated into multiple languages for reference. Only the English version of this document is the final and definitive format released by Diodes Incorporated.

LIFE SUPPORT

Diodes Incorporated products are specifically not authorized for use as critical components in life support devices or systems without the express written approval of the Chief Executive Officer of Diodes Incorporated. As used herein:

A. Life support devices or systems are devices or systems which:

1. are intended to implant into the body, or

2. support or sustain life and whose failure to perform when properly used in accordance with instructions for use provided in the labeling can be reasonably expected to result in significant injury to the user.

B. A critical component is any component in a life support device or system whose failure to perform can be reasonably expected to cause the failure of the life support device or to affect its safety or effectiveness.

Customers represent that they have all necessary expertise in the safety and regulatory ramifications of their life support devices or systems, and acknowledge and agree that they are solely responsible for all legal, regulatory and safety-related requirements concerning their products and any use of Diodes Incorporated products in such safety-critical, life support devices or systems, notwithstanding any devices- or systems-related information or support that may be provided by Diodes Incorporated. Further, Customers must fully indemnify Diodes Incorporated and its representatives against any damages arising out of the use of Diodes Incorporated products in such safety-critical, life support devices or systems.

Copyright © 2016, Diodes Incorporated

www.diodes.com