

High-performance HDMITM Signal Switch w/ Integrated Side-band Signal Support

Features

- 4-Differential Channel 2:1 Mux/DeMux + 2-Channel 2:1 Mux/DeMux
- Deep Color™ Support
- Data Rate: 4.0Gbps for high data channels
- Clock rate max support @ 340 MHz
- Supports both AC coupled and DC coupled signals
- Switching speed: 4ns
- Isolation: -40dB@1GHz for high-speed channels
- Integrated ESD protection; HBM ESD: 2KV per JEDEC Standard
- High-speed data bits; Contact Discharge ESD: 2KV per IEC61000-4-2 standard
- Side band signal bits: 2kV HBM
- Low bit-to-bit skew
- Enable/Disable time: 9ns
- Bidirectional
- Packaging (Pb-free & Green):
 - 48-pin BQSOP (B)

Description

Diodes' PI3HDMI™ series of switch circuits are targeted for high-resolution video networks that are based on DVI/HDMI™ standards, and TMDS signal processing. The PI3HDMI1210-A is a 2-to-1 HDMI™ Mux/DeMux Switch. The device multiplexes differential signals to one of two corresponding HDMI™ inputs. The switch is bidirectional and offers little or no attenuation of the high-speed signals at the outputs. It is designed for low bit-to-bit skew and high channel-to-channel noise isolation.

The maximum DVI/HDMI™ data rate of 4.0Gbps provides the resolution required by the next generation HDTV and PC graphics. Three differential channels are used for data (video signals for DVI or audio/video signals for HDMI™), and one differential channel is used for Clock for decoding the TMDS signals at the outputs.

PI3HDMI1210-A was designed specifically to meet ATC-'sink' requirements. Therefore, Pericom recommends locating this switch at the sink to switch between multiple sources.

Block Diagram

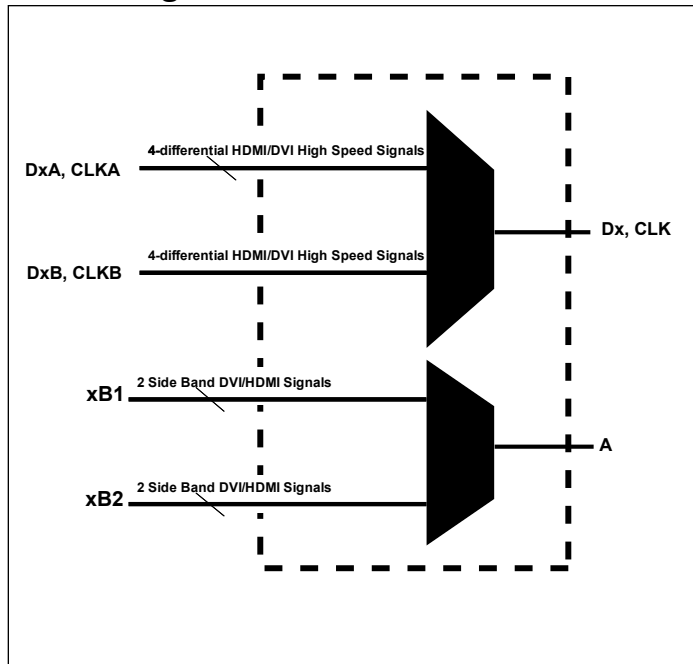

Pin Description

<p>V_{DD}33 1</p> <p>CP 2</p> <p>D0+ 3</p> <p>D0- 4</p> <p>D1+ 5</p> <p>D1- 6</p> <p>V_{DD}33 7</p> <p>SEL 8</p> <p>D2+ 9</p> <p>D2- 10</p> <p>CLK+ 11</p> <p>CLK- 12</p> <p>GND 13</p> <p>V_{DD}33 14</p> <p>GND 15</p> <p>CP 16</p> <p>GND 17</p> <p>A0 18</p> <p>GND 19</p> <p>A1 20</p> <p>IN 21</p> <p>V_{DD}50 22</p> <p>EN 23</p> <p>CP 24</p>	<p>48 D0+A</p> <p>47 D0-A</p> <p>46 D1+A</p> <p>45 D1-A</p> <p>44 D2+A</p> <p>43 D2-A</p> <p>42 CLK+A</p> <p>41 CLK-A</p> <p>40 V_{DD}33</p> <p>39 D0+B</p> <p>38 D0-B</p> <p>37 D1+B</p> <p>36 D1-B</p> <p>35 D2+B</p> <p>34 D2-B</p> <p>33 CLK+B</p> <p>32 CLK-B</p> <p>31 V_{DD}33</p> <p>30 GND</p> <p>29 0B1</p> <p>28 0B2</p> <p>27 1B1</p> <p>26 1B2</p> <p>25 GND</p>
---	---

Pin Description

Pin Name	Description
V_{DD}^{33}	3.3V Power supply
CP	Tie this pin to GND via 0.1 μ F capacitor for optimal operation
V_{DD}^{50}	5.0V Power supply
Dx	High Speed TMDS signal I/O
DxA, DxB	High Speed TMDS signal I/O
SEL	High Speed Signal Control
IN	Side Band Signal Control
Ax, xB1, xB2	Side Band Signal I/O
GND	GND pin
EN	Global Enable for Side Band Signals
CLK, CLKA/B	TMDS CLK signal I/O

Truth Table

SEL(pin8)	Function ⁽¹⁾
L	CLK \rightarrow CLKA
L	$D_x \rightarrow D_xA$
H	$D_x \rightarrow D_xB$
H	CLK \rightarrow CLKB

\overline{EN} (pin23)	IN(pin21)	Function ⁽²⁾
L	L	$A_n \rightarrow B_1$
L	H	$A_n \rightarrow B_2$
H	X	$A_n = B_1 = B_2 = H_1 - Z$

Note:

1) x=0,1,2,3

2) n=0,1

Maximum Ratings

(Above which useful life may be impaired. For user guidelines, not tested.)

Storage Temperature.....	-65°C to +150°C
DC Input Voltage for side band signals.....	-0.5V to 5.5V
DC Output Current.....	20mA
Power Dissipation.....	0.5W
Supply Voltage V _{DD33}	-0.3V to 4.0V
Supply Voltage V _{DD50}	-0.35V to 6.0V

Note:

Stresses greater than those listed under MAXIMUM RATINGS may cause permanent damage to the device. This is a stress rating only and functional operation of the device at these or any other conditions above those indicated in the operational sections of this specification is not implied. Exposure to absolute maximum rating conditions for extended periods may affect reliability.

DC Power Supply Characteristics

Parameter	Description	Min.	Max.	Units
V _{DD33}	3.3V Power Supply	3.0	3.6	V
V _{DD50}	5.0 Power Supply	4.2	5.5	V

DC Electrical Characteristics for Switching over Operating Range

(T_A = -40°C to +85°C for high speed signals only)

Parameter	Description	Test Conditions	Min.	Typ ⁽²⁾	Max.	Units
V _{IHSEL} ⁽³⁾	Input HIGH Voltage	Guaranteed HIGH level	2.8			V
V _{ILSEL} ⁽³⁾	Input LOW Voltage	Guaranteed LOW level	1.3		2.0	
V _{IKHS}	Clamp Diode Voltage	V _{DD} =Max., I _{IN} =-18mA			0.9	

Notes:

- For Max. or Min. conditions, use appropriate value specified under Electrical Characteristics for the applicable device type.
- Typical values are at T_A = 25°C ambient and maximum loading.
- V_{IHSEL} + V_{ILSEL} are for SEL input only (pin 8)

DC Electrical Characteristics for Switching over Operating Range

(T_A = -40°C to +85°C) for side band signals only

Parameter	Description	Test Conditions	Min.	Typ ⁽²⁾	Max.	Units
V _{IHIN} ⁽³⁾	Input HIGH Voltage	Guaranteed HIGH level	2.1			V
V _{ILIN} ⁽³⁾	Input LOW Voltage	Guaranteed LOW level			0.8	
V _{IKSB} ⁽⁴⁾	Clamp Diode Voltage	V _{DD} =Max., I _{IN} =-18mA			-0.5	
I _{IH}	Input HIGH Current	V _{DD} =Max., V _{IN} =V _{DD}			±5	μA
I _{IL}	Input LOW Current	V _{DD} =Max., V _{IN} =GND			±5	

Notes:

- For Max. or Min. conditions, use appropriate value specified under Electrical Characteristics for the applicable device type.
- Typical values are at T_A = 25°C ambient and maximum loading.
- V_{IHIN} + V_{ILIN} are for IN input only.

Power Supply Characteristics

Parameters	Description	Test Conditions ⁽¹⁾	Min.	Typ. ⁽²⁾	Max.	Units
I_{CC}	Quiescent Power Supply Current	$V_{DD} = \text{Max.}, V_{IN} = V_{DD} \text{ or GND}$		11	15	mA

Notes:

- For Max. or Min. conditions, use appropriate value specified under Electrical Characteristics for the applicable device type.
- Typical values are at $T_A = 25^\circ\text{C}$ ambient and maximum loading.

Dynamic Electrical Characteristics Over the Operating Range ($T_A = -40^\circ$ to $+85^\circ\text{C}$)

Parameter	Description	Test Conditions	Min.	Typ. ⁽³⁾	Max.	Units
$X_{TALK_{HS}}^{(1)}$	Crosstalk	See Fig. 1 for Measurement Setup, $f = 1.65\text{Gbps}$		-30		dB
$X_{TALK_{SB}}^{(2)}$		$f = 10\text{MHz}$		-62		
$O_{IRR_{HS}}^{(1)}$	OFF Isolation	See Fig. 2 for Measurement Setup, $f = 1.65\text{Gbps}$		-40		
$O_{IRR_{SB}}^{(2)}$		10MHz		-67		
$BW_{HS\ DATA}^{(1)}$	-3dB Bandwidth for HS data			2.3		GHz
$IL_{HS}^{(1)}$	Insertion Loss	@1.65 Gbps (8-bit deep color)		-0.87		dB
		@2.0625 Gbps (10-bit deep color)		-0.96		
		@2.475 Gbps (12-bit deep color)		-1.18		
		@3.3 Gbps (16-bit deep color)		-1.84		
$BW_{CLOCK}^{(4)}$	-3dB Bandwidth for CLK			1.7		GHz

Notes:

- High-speed signal path only
- Side-band signal path only
- Typical values are @ $T_A = 25^\circ\text{C}$ ambient
- BW measured on CLK pins only (11, 12, 32, 33, 41 & 42)

Switching Characteristics

($T_A = -40^\circ$ to $+85^\circ\text{C}$, $V_{DD33} = 3.3\text{V} \pm 10\%$, $V_{DD50} = 5.0\text{V} \pm 10\%$)

Parameter	Description	Min.	Typ. ⁽²⁾	Max.	Units
t_{PZH}, t_{PZL}	Line Enable Time - SEL to A_N, B_N	0.5		8.0	ns
t_{PHZ}, t_{PLZ}	Line Disable Time - SEL to A_N, B_N	0.5		4.0	

Notes:

- For measurement setup, please see “Test Circuit For Electrical Characteristic” on page 6, and “Switching waveforms” on page 7

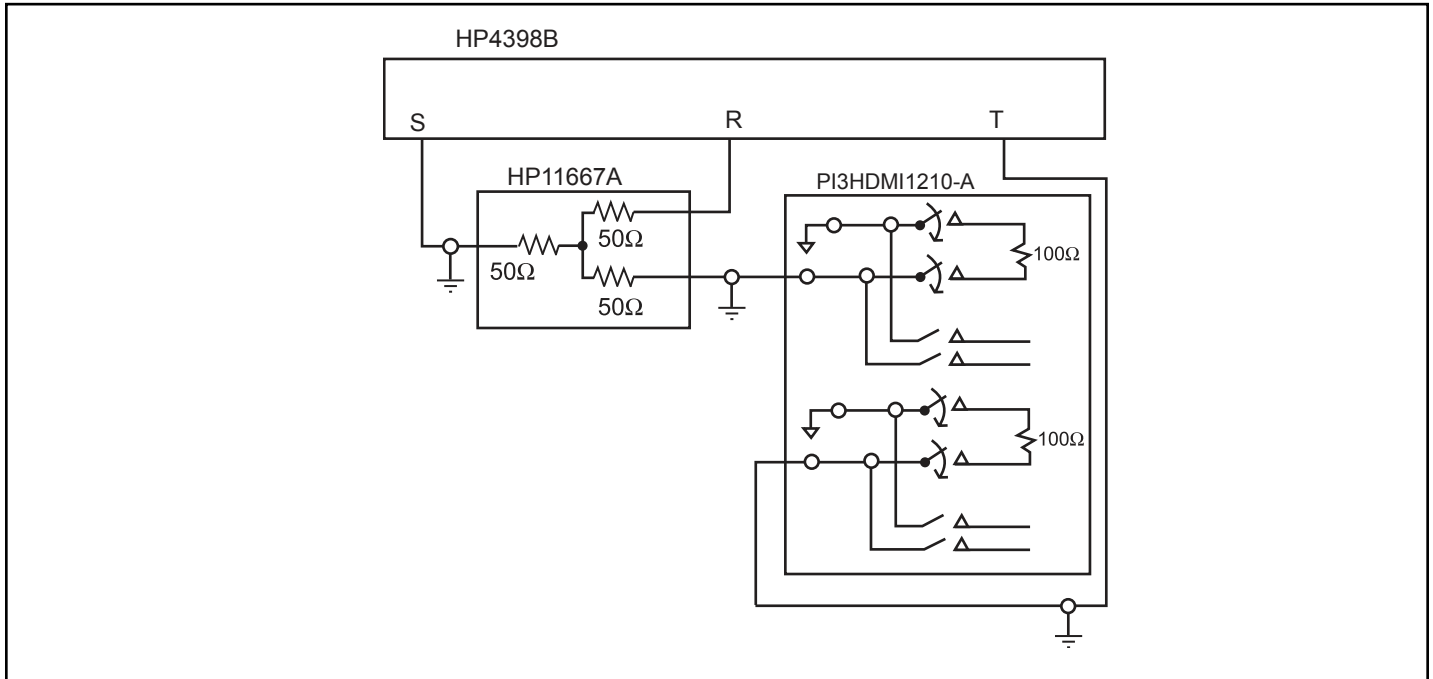

Fig 1. Crosstalk Setup

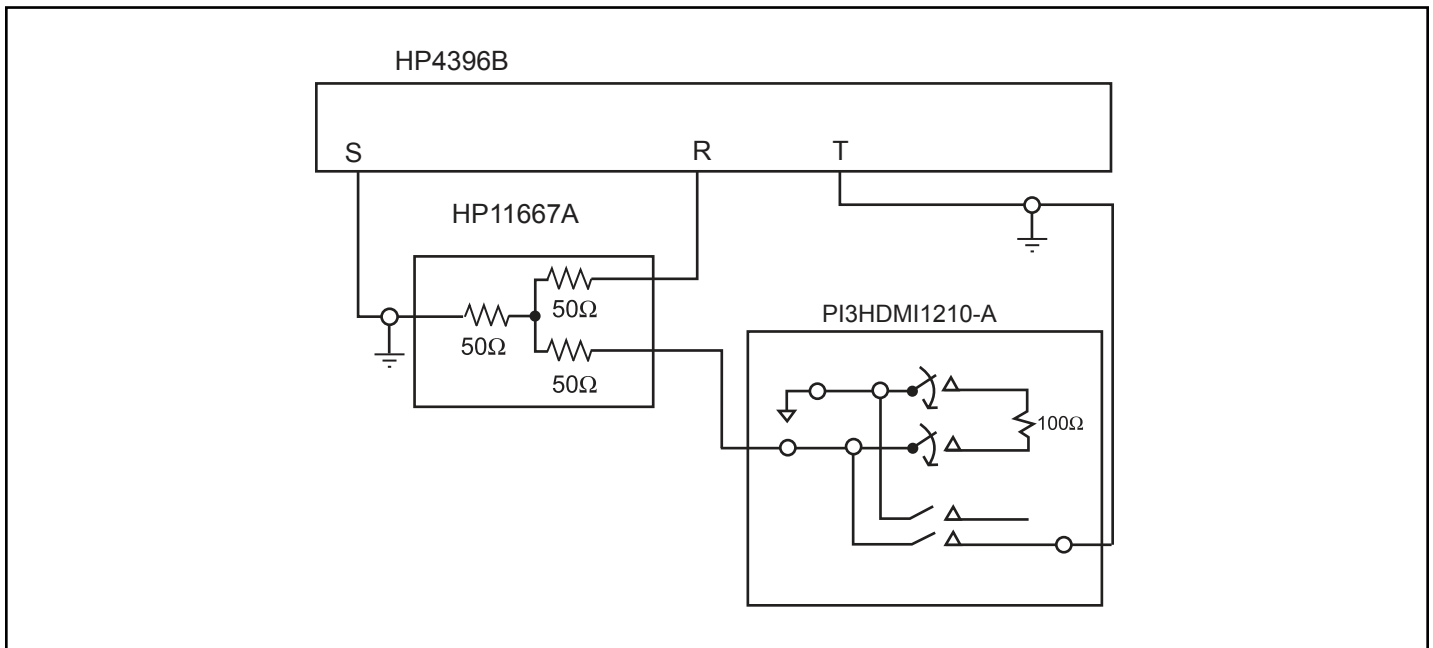

Fig 2. Off-isolation setup

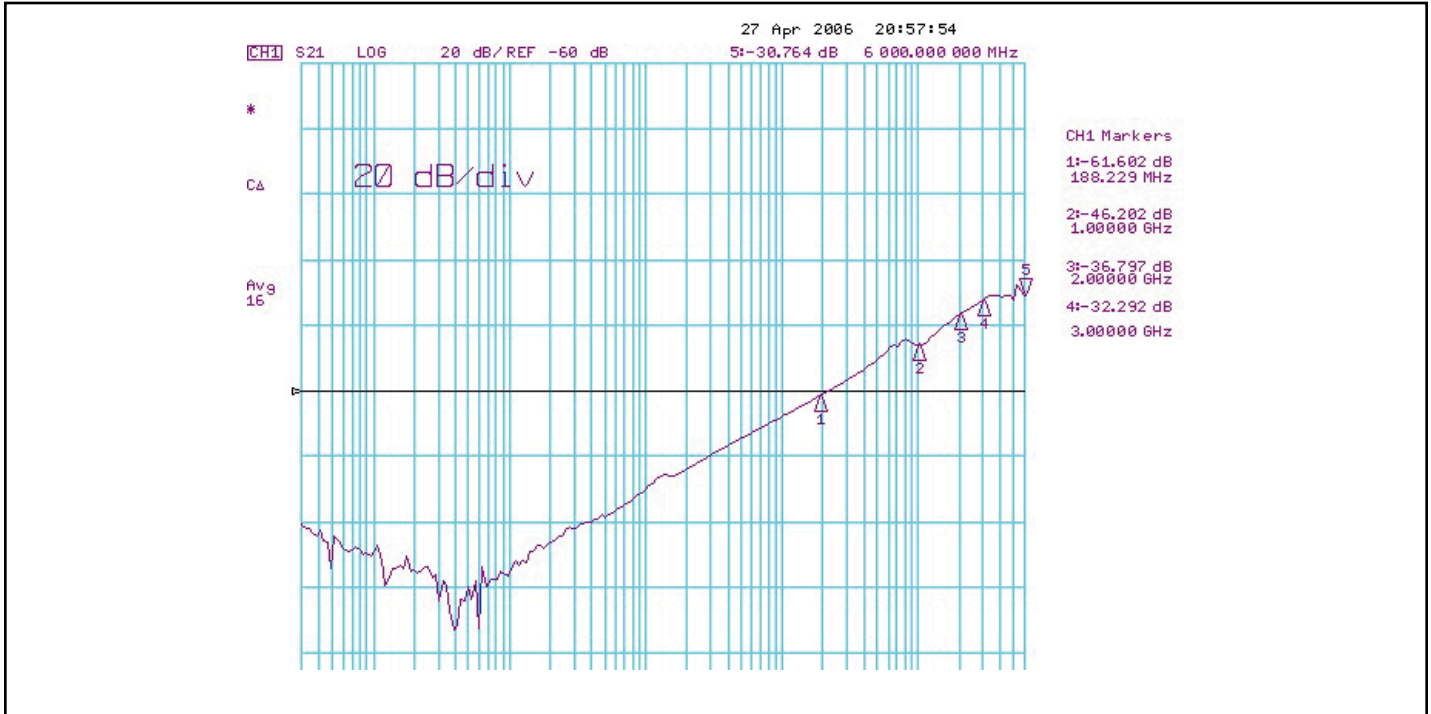

Fig 3. Crosstalk for High-speed data signals only

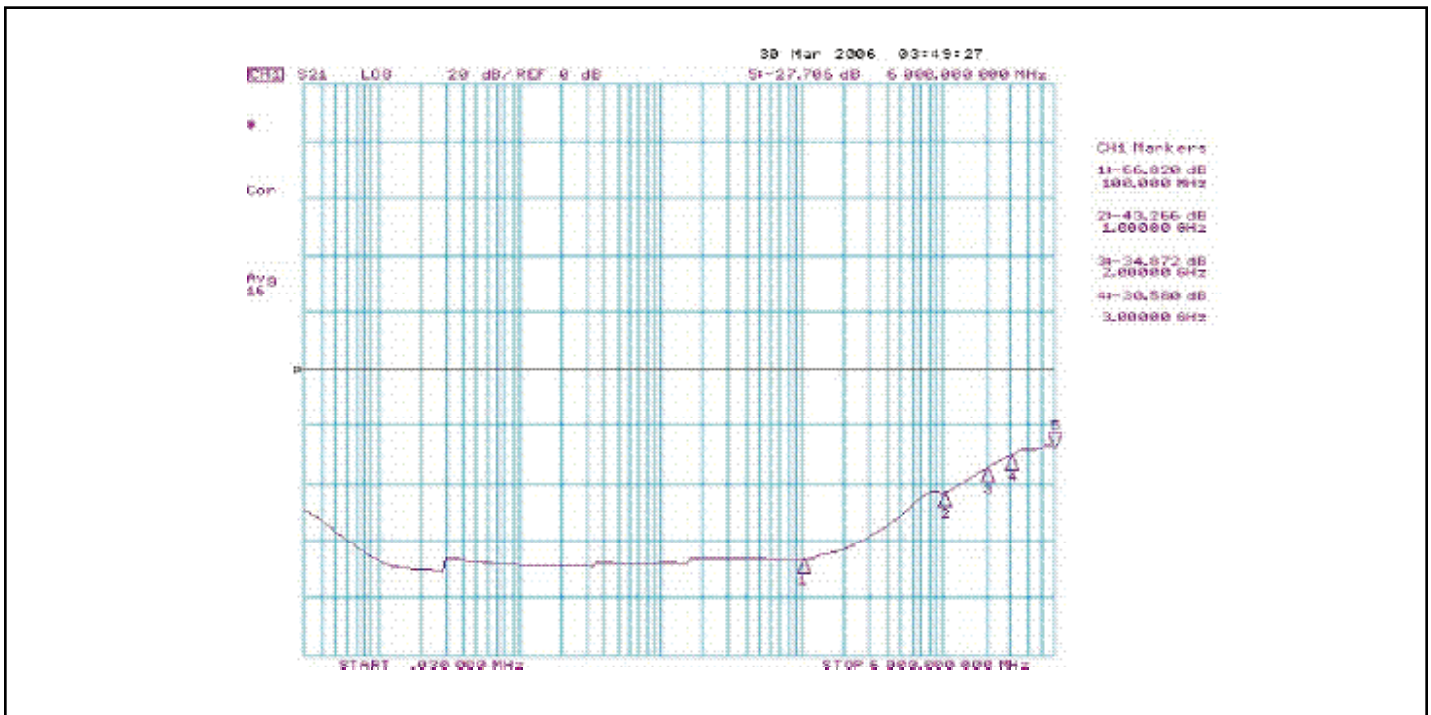

Fig 4. Off Isolation for high-speed data signals only

PI3HDMI1210-A

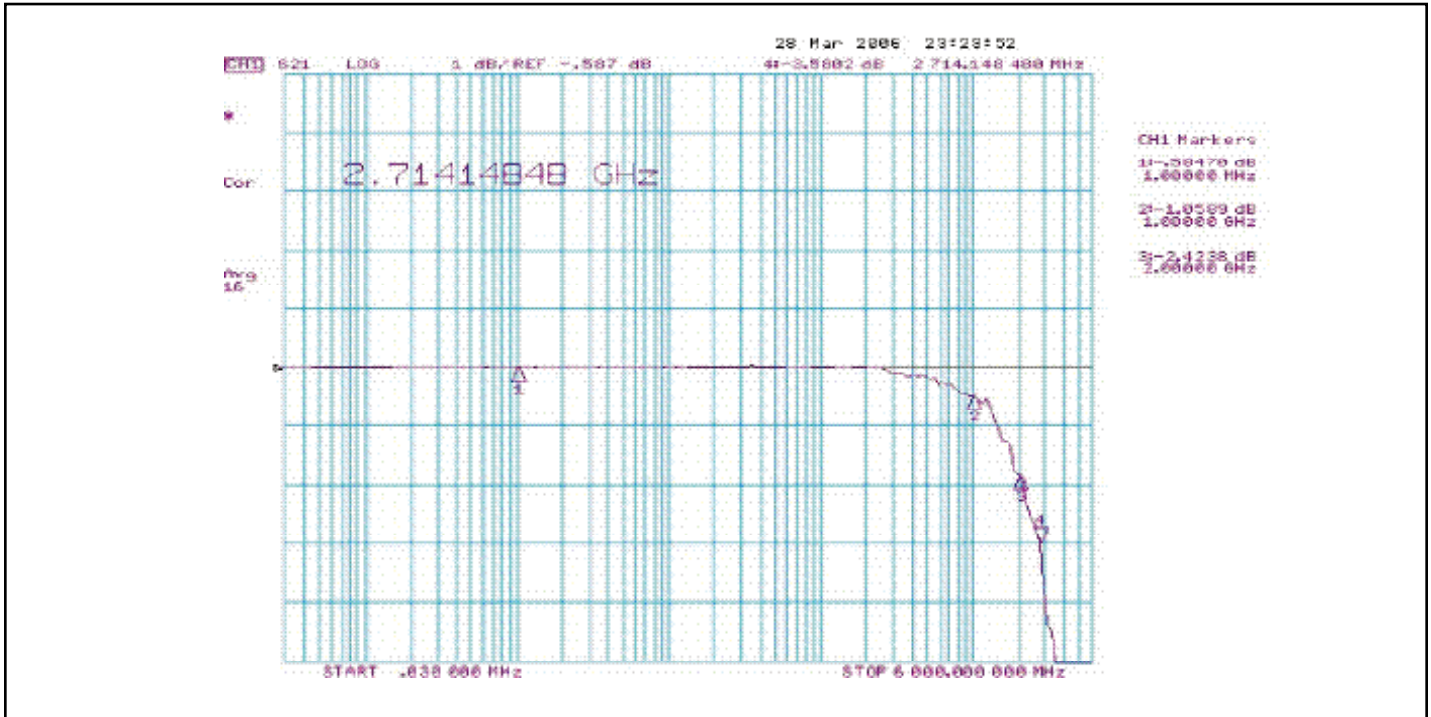
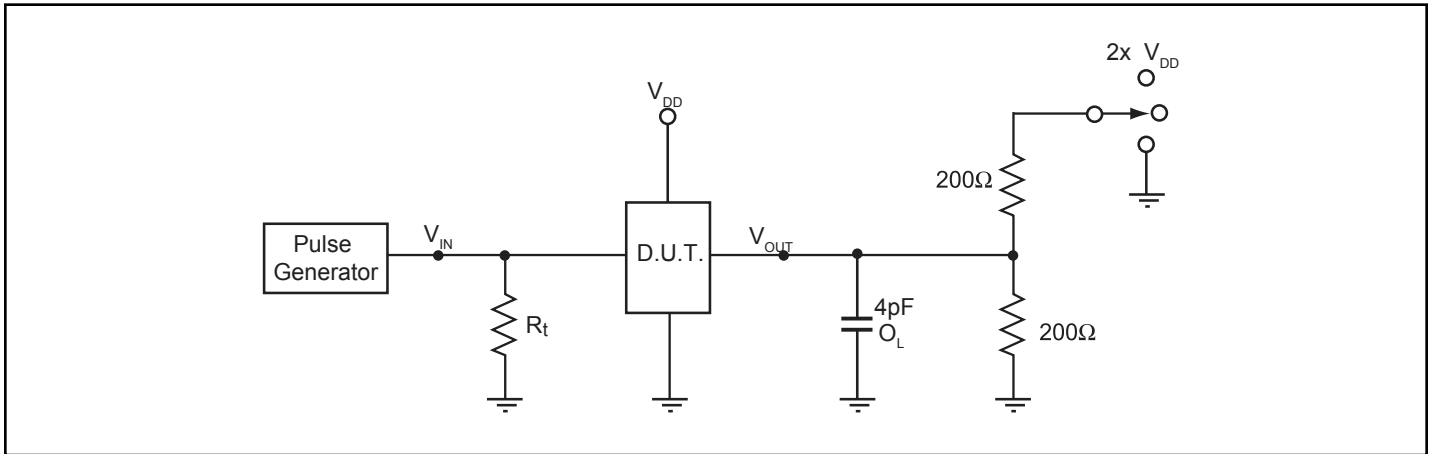

Fig 5. Insertion loss for high-speed data signals only

Test Circuit for Electrical Characteristics⁽¹⁾



Notes:

1. C_L = Load capacitance: includes jig and probe capacitance.
2. R_T = Termination resistance: should be equal to Z_{OUT} of the Pulse Generator
3. Waveform 1 is for an output with internal conditions such that the output is low except when disabled by the output control.
Waveform 2 is for an output with internal conditions such that the output is high except when disabled by the output control.
4. All input impulses are supplied by generators having the following characteristics: $PRR \leq \text{MHz}$, $Z_O = 50\Omega$, $t_R \leq 2.5\text{ns}$, $t_F \leq 2.5\text{ns}$.
5. The outputs are measured one at a time with one transition per measurement.

Switch Positions

Test	Switch
t_{PLZ} , t_{PZL} (output on B-side)	$2 \times (V_{DD}/3)$
t_{PHZ} , t_{PZH} (output on B-side)	GND
Prop Delay	Open

Test Circuit for Dynamic Electrical Characteristics

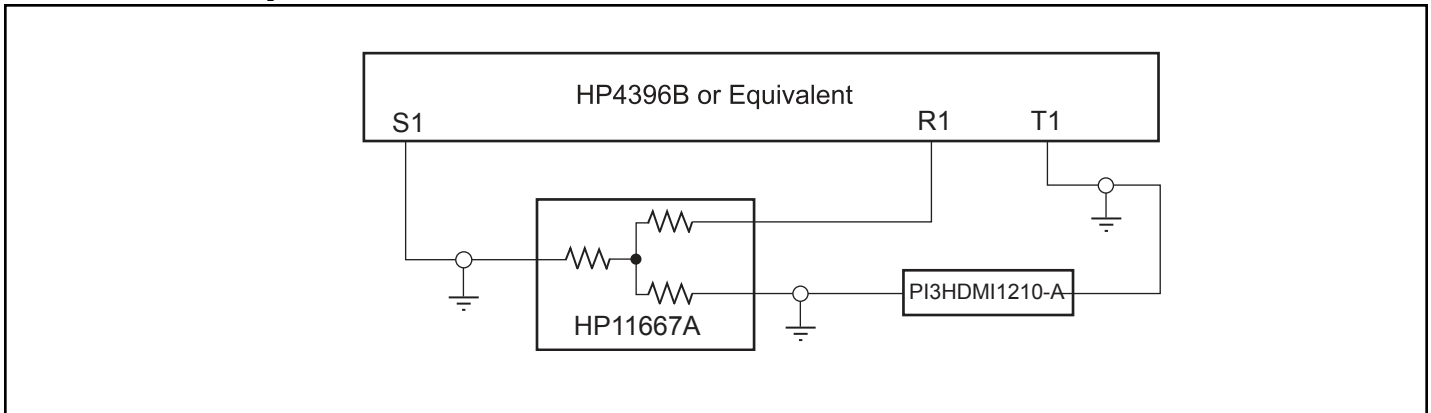

Switching Waveforms

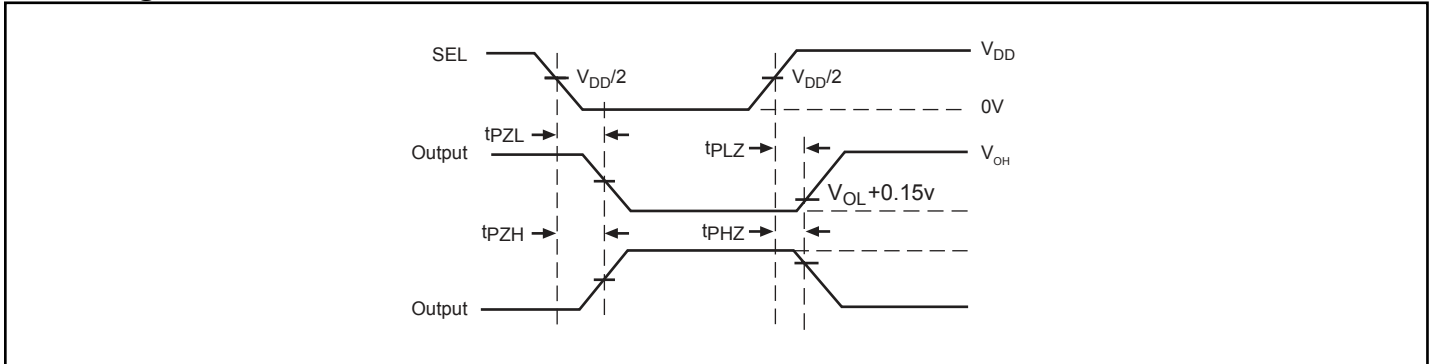

Voltage Waveforms Enable and Disable Times

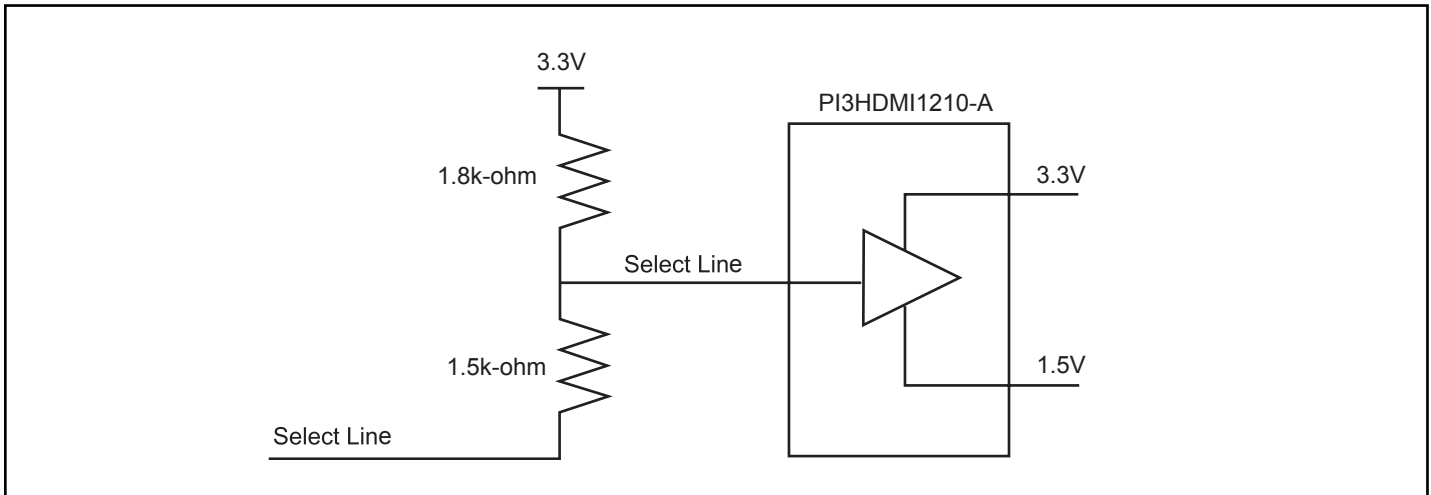

Example of a circuit that needs to be connected to the SEL pin (8) of the PI3HDMI1210-A of our device

Application Test Results

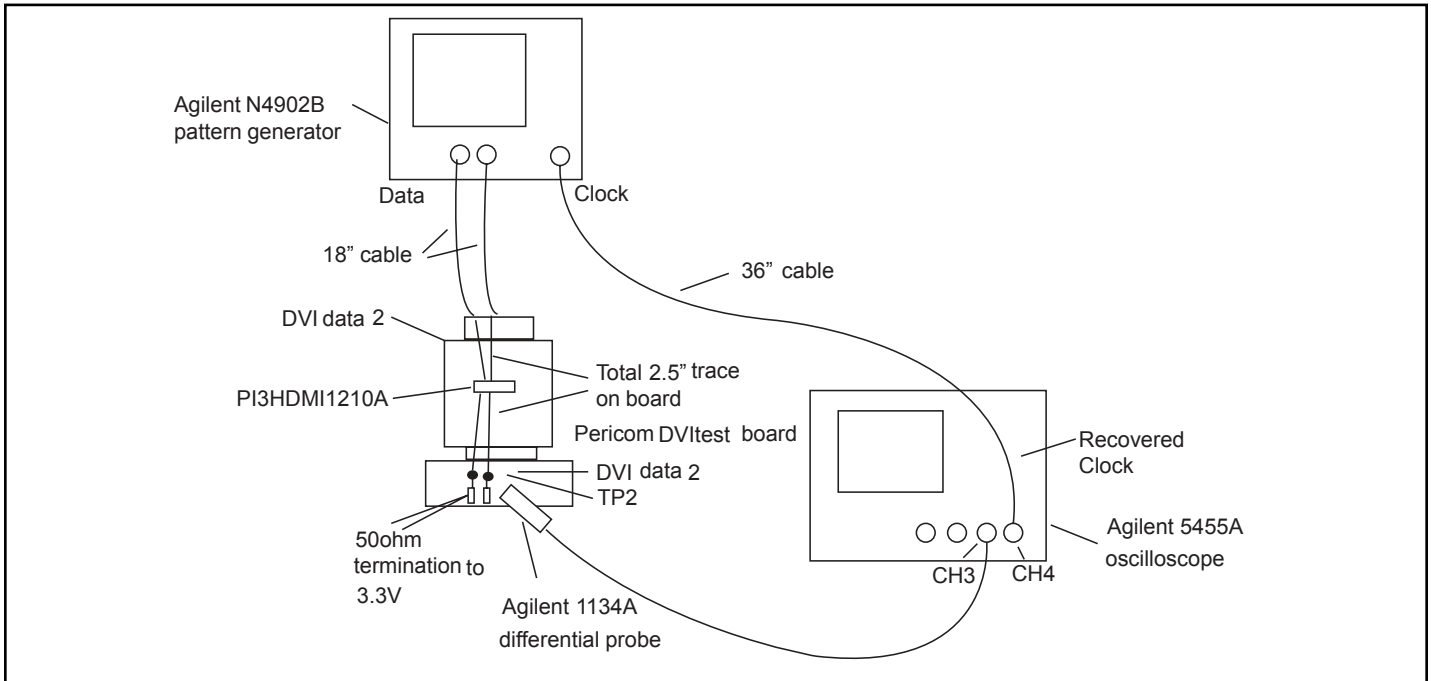

Figure 6. TMD5 TP2 Tx eye compliance test setup

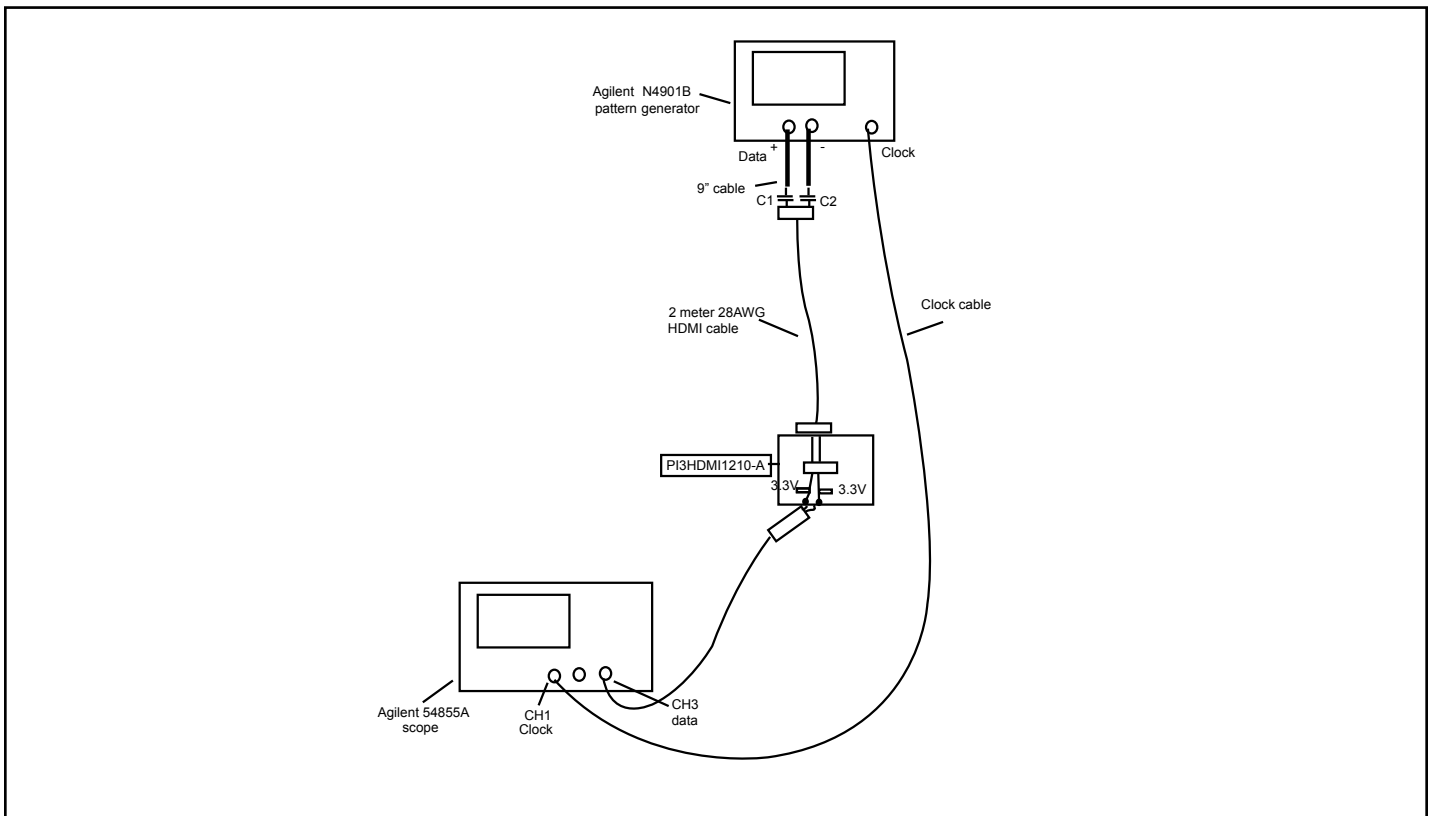

Figure 7. TMD5 TP3 Rx "switch at receiver" eye compliance test setup

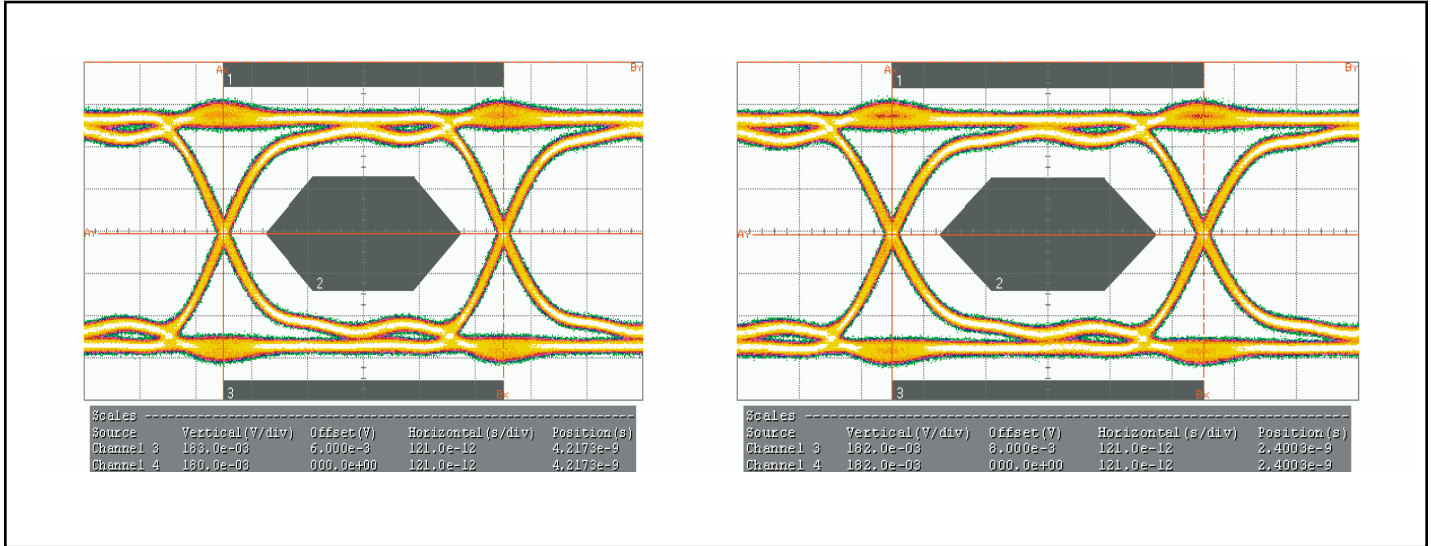

Figure 8. TP2 (Tx) eye-measurements (left is with switch, right is without switch), refer to figure 1 for the test set up

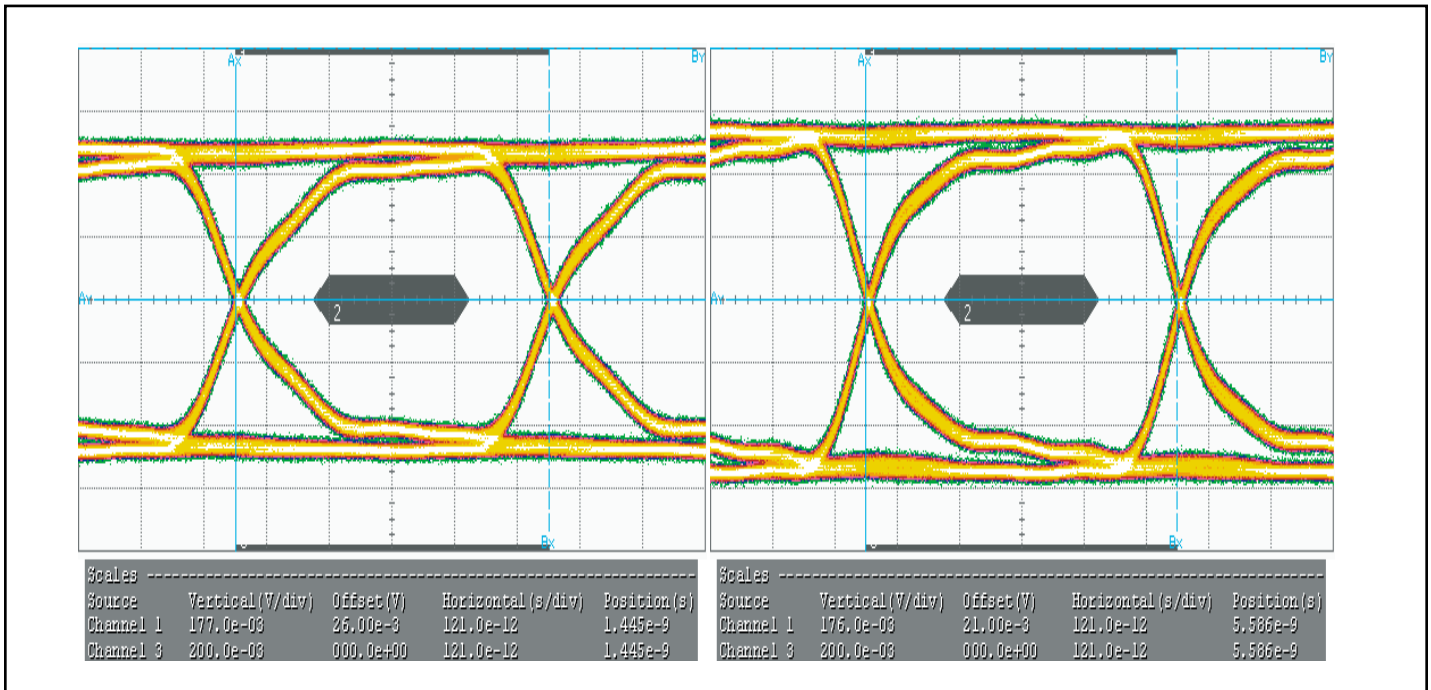
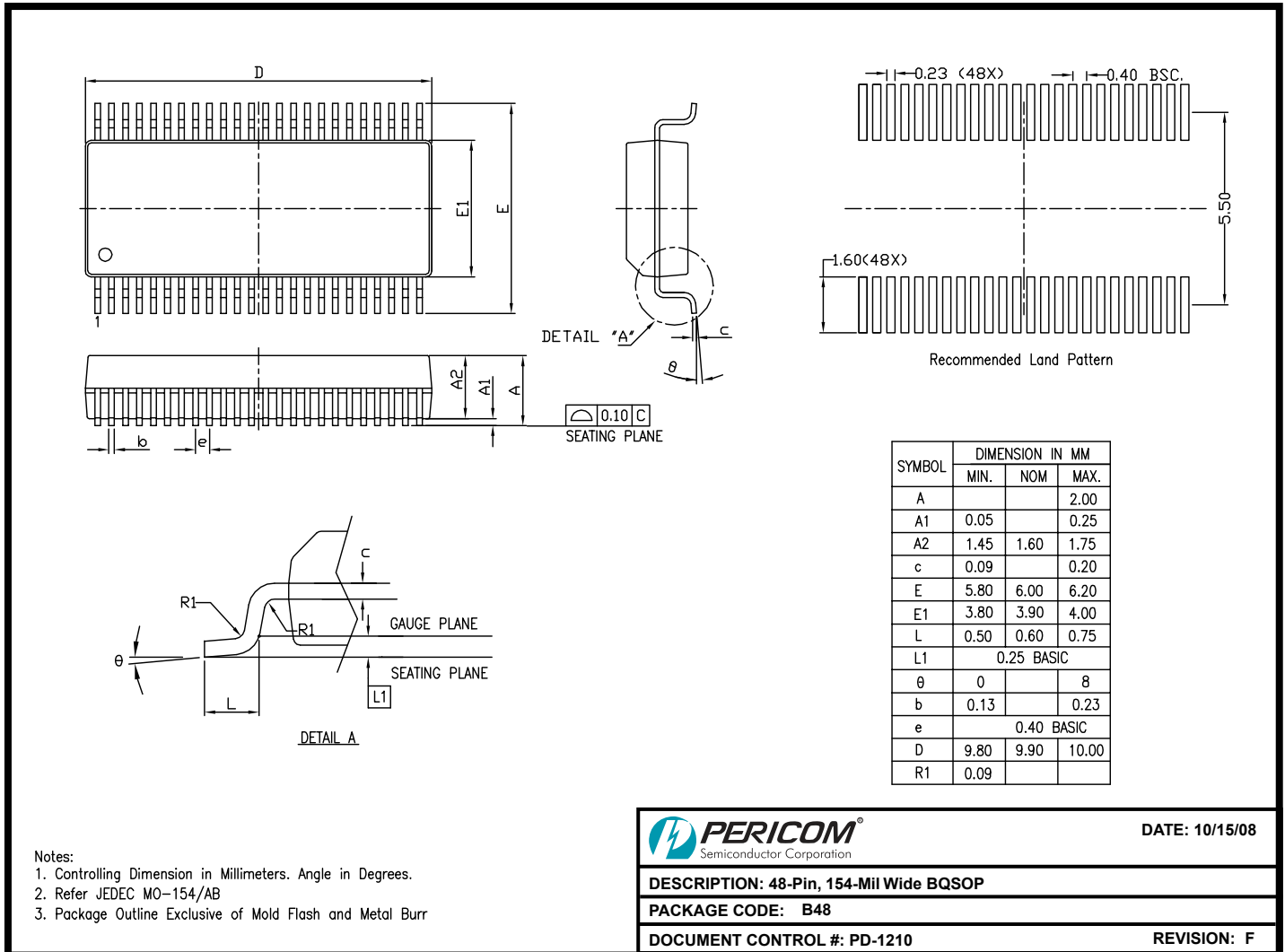

Figure 9. TP3 (Rx) - "Switch at receiver side" with 2-meter cable eye-measurements (left is with switch, right is without switch), refer to figure 2 for the test set up.

Packaging Mechanical: 48-pin BQSOP (B)



Notes:

1. Controlling Dimension in Millimeters. Angle in Degrees.
2. Refer JEDEC MO-154/AB
3. Package Outline Exclusive of Mold Flash and Metal Burr



DATE: 10/15/08

DESCRIPTION: 48-Pin, 154-Mil Wide BQSOP

PACKAGE CODE: B48

DOCUMENT CONTROL #: PD-1210

REVISION: F

08-0522

For latest package info.

please check: <http://www.diodes.com/design/support/packaging/pericom-packaging/packaging-mechanicals-and-thermal-characteristics/>

Ordering Information

Ordering Code	Package Code	Package Description
PI3HDMI1210-ABEX	B	48-pin, 154-Mil Wide (BQSOP)

Notes:

- Thermal characteristics can be found on the company web site at www.diodes.com/design/support/packaging/
- E = Pb-free and Green
- X suffix = Tape/Reel

IMPORTANT NOTICE

DIODES INCORPORATED MAKES NO WARRANTY OF ANY KIND, EXPRESS OR IMPLIED, WITH REGARDS TO THIS DOCUMENT, INCLUDING, BUT NOT LIMITED TO, THE IMPLIED WARRANTIES OF MERCHANTABILITY AND FITNESS FOR A PARTICULAR PURPOSE (AND THEIR EQUIVALENTS UNDER THE LAWS OF ANY JURISDICTION).

Diodes Incorporated and its subsidiaries reserve the right to make modifications, enhancements, improvements, corrections or other changes without further notice to this document and any product described herein. Diodes Incorporated does not assume any liability arising out of the application or use of this document or any product described herein; neither does Diodes Incorporated convey any license under its patent or trademark rights, nor the rights of others. Any Customer or user of this document or products described herein in such applications shall assume all risks of such use and will agree to hold Diodes Incorporated and all the companies whose products are represented on Diodes Incorporated website, harmless against all damages.

Diodes Incorporated does not warrant or accept any liability whatsoever in respect of any products purchased through unauthorized sales channel.

Should Customers purchase or use Diodes Incorporated products for any unintended or unauthorized application, Customers shall indemnify and hold Diodes Incorporated and its representatives harmless against all claims, damages, expenses, and attorney fees arising out of, directly or indirectly, any claim of personal injury or death associated with such unintended or unauthorized application.

Products described herein may be covered by one or more United States, international or foreign patents pending. Product names and markings noted herein may also be covered by one or more United States, international or foreign trademarks.

This document is written in English but may be translated into multiple languages for reference. Only the English version of this document is the final and definitive format released by Diodes Incorporated.

LIFE SUPPORT

Diodes Incorporated products are specifically not authorized for use as critical components in life support devices or systems without the express written approval of the Chief Executive Officer of Diodes Incorporated. As used herein:

A. Life support devices or systems are devices or systems which:

1. are intended to implant into the body, or
2. support or sustain life and whose failure to perform when properly used in accordance with instructions for use provided in the labeling can be reasonably expected to result in significant injury to the user.

B. A critical component is any component in a life support device or system whose failure to perform can be reasonably expected to cause the failure of the life support device or to affect its safety or effectiveness.

Customers represent that they have all necessary expertise in the safety and regulatory ramifications of their life support devices or systems, and acknowledge and agree that they are solely responsible for all legal, regulatory and safety-related requirements concerning their products and any use of Diodes Incorporated products in such safety-critical, life support devices or systems, notwithstanding any devices- or systems-related information or support that may be provided by Diodes Incorporated. Further, Customers must fully indemnify Diodes Incorporated and its representatives against any damages arising out of the use of Diodes Incorporated products in such safety-critical, life support devices or systems.

Copyright © 2016, Diodes Incorporated
www.diodes.com