



PI3HDMI412AD

1:2 Active HDMI™ Compatible DeMux with Advanced ReDriver™ Functionality for Enhanced Signal Integrity

Features

- Supply voltage, $V_{DD} = 3.3V \pm 5\%$
- Compatible w/ DVI, HDMI™ 1.1, 1.2, and 1.3 signals
- Supports both AC-coupled and DC-coupled inputs
- 1:2 Demux
- Supports Deep Color™ Signals
- Configurable output swing control (500mV, 750mV, 1000mV)
- Configurable Pre-Emphasis levels (0dB, 1.5dB, 3.5dB, 6.0dB)
- Configurable De-Emphasis (0dB, -1.5dB, -3.5dB, -6.0dB)
- Configurable Equalization (1dB, 3.5dB, 6dB, 8dB)
- Data Rate = 2.5Gbps (Max)
- Inputs w/ built-in termination
- Propagation delay < 2ns input
- Uni-Directional
- 10kV HBM ESD protection on all high speed data channels (Supplemental contact ESD test results are available upon request)
- Packaging (Pb-free & Green): 56-pad TQFN (ZB56)

Description

Pericom Semiconductor's PI3HDMI412AD, active-drive switch solution is targeted for high-resolution video networks that are based on DVI/HDMI™ standards, and TMDS signal processing. The PI3HDMI412AD is an active single TMDS channel to two TMDS channel DeMux with Hi-Z outputs. The device drives differential signals to multiple video display units. It provides three controllable output swing levels that can be controlled through pin control or I²C control, depending on the mode select pin. The swing levels are 500mV, 700mV & 1000mV. This solution also provides a unique advanced pre-emphasis technique to increase rise and fall times which are reduced during transmission across long distances.

The maximum DVI/HDMI™ data rate of 1.65Gbps provides a 1920x1080 resolution required by the next Gen HDTV and PC graphics products. Due to its active uni-directional feature, this switch is de-signed for usage only for the video driver's side. For PC graphics application, the device sits at the driver's side to switch between multiple display units, such as PC LCD monitor, projector, TV, etc.

PI3HDMI412AD is the industry's first active DVI/HDMI™ compliant switch, which ensures transmitting high bandwidth video streams from PC graphics source to end display units. PI3HDMI412AD will also provide enhanced robust ESD/EOS protection, which is required by many consumer video networks today.

Block Diagram

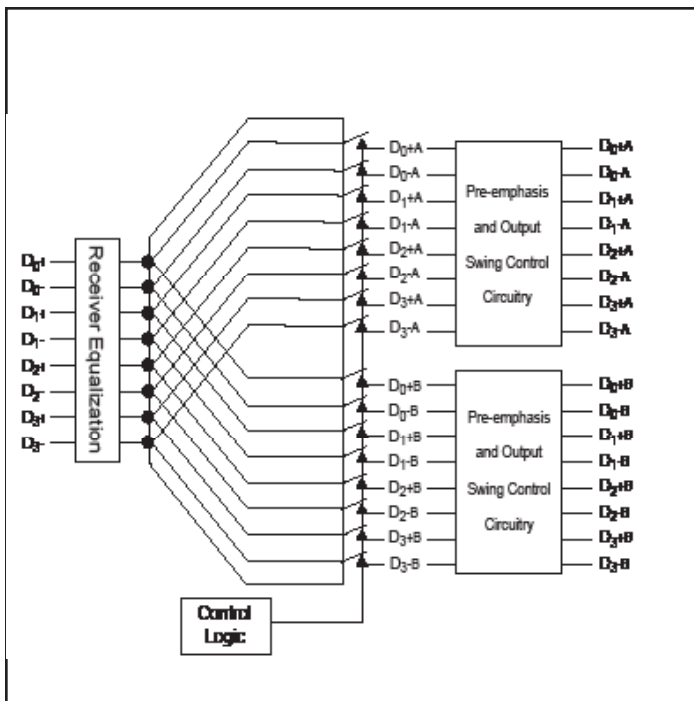

Pin Configuration

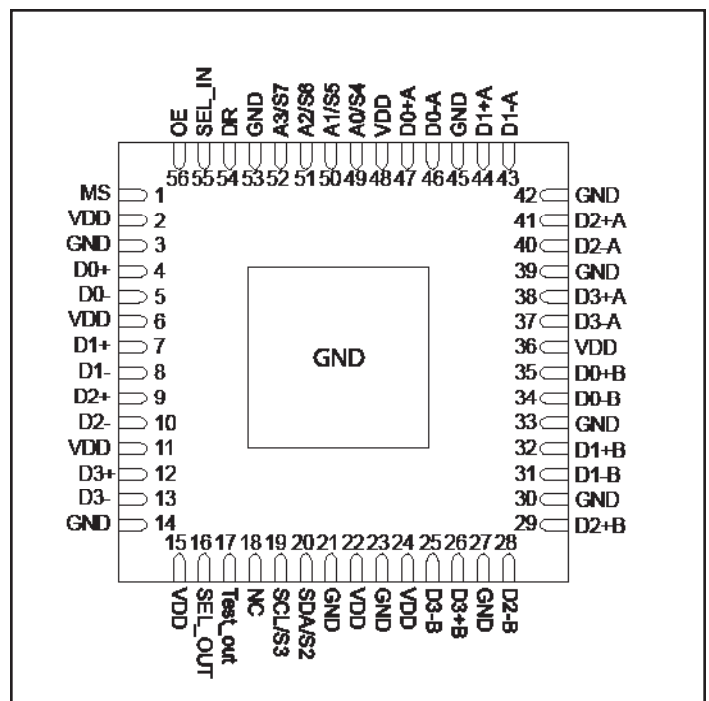

Function Block Description

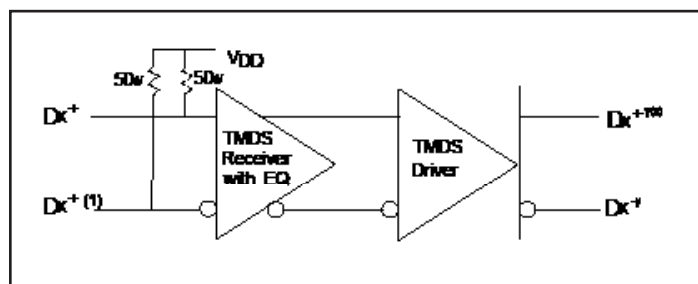

Notes:

1. X = 0,1,2,3
2. Y = A,B

Maximum Ratings (Above which useful life may be impaired. For user guidelines, not tested.)

Storage Temperature.....	-65°C to +150°C
Supply Voltage to Ground Potential.....	-0.5V to +5V
DC Input Voltage.....	-0.5V to V _{DD}
DC Output Current.....	120mA
Power Dissipation.....	1.0W

Note: Stresses greater than those listed under MAXIMUM RATINGS may cause permanent damage to the device. This is a stress rating only and functional operation of the device at these or any other conditions above those indicated in the operational sections of this specification is not implied. Exposure to absolute maximum rating conditions for extended periods may affect reliability.

Pin Description

Pin #	Pin Name	I/O	Description
2, 6, 11, 15, 22, 24, 36, 48	V _{DD}	Power	3.3V power supply
3, 14, 21, 23, 27, 30, 33, 39, 42, 45, 53	GND	Power	0V power supply
16	SEL_Out	O	Output bit, that provides information to user as to which port is active, if SEL_OUT = 'LOW', then Port A is active, if SEL_OUT = 'HIGH', then Port B is active. Only used when MS pin is 'HIGH'
19	SCL	I	I ² C Clock Input Signal
20	SDA	I/O	I ² C Data Input/Output Signal
18	NC	N/A	No Connect.
1	MS	I	Mode Select Pin. If MS = 'HIGH', then I ² C control is active. Pins 49-52 are I ² C address and pin 19 is SCL and pin 20 is SDA. If MS = 'LOW', then I ² C control is inactive and pin programmability is active. Pins 49-52 are control pins only for Port A, S4-S7 and pin 19 is S2 and pin 20 is S3. If 'MS' = "LOW", Port B cannot be configured and is left as default. Port B default value is 0dB pre-emphasis, 0dB de-emphasis, and 500mV output swing
55	SEL_IN	I	Output port select. (Logically similar to I ² C bit S1 - see page 3)
54	Direction Control	I	Logic High = Signal demux mode operation Logic Low = Signal split mode operation
56	OE	I	Output is enabled and normal when OE = 'HIGH'. If OE = 'LOW', both outputs, A and B, are disabled and at Hi-Z
17	Test_Out	O	Output pin for internal testing. Not used for normal operation
4, 5, 7, 8, 9, 10, 12, 13	Dx	I	Input TMDS high speed signals
28, 29, 31, 32, 34, 35, 40, 41, 43, 44, 46, 47, 25, 26, 37, 38	Dx ^y	O	Output TMDS high speed signals
49,50, 51, 52	A0, A1, A2, A3	I	I ² C address inputs if MS = 'HIGH'.
49,50, 51, 52	S4, S5, S6, S7	I	If MS = 'LOW', then pins 49-52 are control bits S4-S7 for port A only, as shown in truth table on page 3 of datasheet
19	S3	I	If MS = 'LOW', then pins 19 is control bit S3, as shown in the truth table on page 3
20	S2	I	If MS = 'LOW', then pins 20 is control bit S2, as shown in the truth table on page 3

I²C Truth Table

(At power up, default values are: Port A is active, signal swing is set to 500mV, pre-emphasis and de-emphasis are at 0dB, and equalization is at 1dB)

Byte 2: S[7:0]=00000001

Output Swing: 500mV
 Pre-emphasis: 0dB
 De-Emphasis: 0dB
 Equalization: 1dB
 Active Port: port A

Byte 3: S[7:0]=00000001

Output Swing: Defined by Byte 2
 Pre-emphasis:
 De-Emphasis:
 Active Port: port A, in normal mode

BYTE 1 (Address Assignment)

Address	A6	A5	A4	A3	A2	A1	A0	R/W
Value	1	1	0	A3	A2	A1	A0	R=1/W=0

BYTE 2 (1st Data byte - Port A control and input control)

Port A and Input Control	S7	S6	S5	S4	S3	S2	S1	S0	Result		
									Swing (mV)	Pre-emphasis (dB)	De-emphasis (dB)
Swing Control	0	0	0	0	x	x	x	x	500	0	0
	0	0	0	1	x	x	x	x	750	0	0
	0	0	1	0	x	x	x	x	1000	0	0
	0	0	1	1	x	x	x	x	N/A	N/A	N/A
Pre-Emphasis	0	1	0	0	x	x	x	x	500	0	0
	0	1	0	1	x	x	x	x	500	1.5	0
	0	1	1	0	x	x	x	x	500	3.5	0
	0	1	1	1	x	x	x	x	500	6.0	0
De-Emphasis	1	0	0	0	x	x	x	x	750	0	0
	1	0	0	1	x	x	x	x	750	0	-1.5
	1	0	1	0	x	x	x	x	750	0	-3.5
	1	0	1	1	x	x	x	x	750	0	-6.0
Output Port Select	x	x	x	x	x	x	0	1	Port A is active		
	x	x	x	x	x	x	1	1	Port B is active		
	x	x	x	x	x	x	x	0	Port A = Hi-Z		
Equalization (dB)	x	x	x	x	0	0	x	x	1		
	x	x	x	x	0	1	x	x	3.5		
	x	x	x	x	1	0	x	x	6		
	x	x	x	x	1	1	x	x	8		

BYTE 3 (2nd Data byte - Port B control)

Port B Control only	S7	S6	S5	S4	S3	S2	S1	S0	Result		
									Swing (mV)	Pre-emphasis (dB)	De-emphasis (dB)
Swing Control	0	0	0	0	x	x	x	x	500	0	0
	0	0	0	1	x	x	x	x	750	0	0
	0	0	1	0	x	x	x	x	1000	0	0
	0	0	1	1	x	x	x	x	N/A	N/A	N/A
Pre-Emphasis	0	1	0	0	x	x	x	x	500	0	0
	0	1	0	1	x	x	x	x	500	1.5	0
	0	1	1	0	x	x	x	x	500	3.5	0
	0	1	1	1	x	x	x	x	500	6.0	0
De-Emphasis	1	0	0	0	x	x	x	x	750	0	0
	1	0	0	1	x	x	x	x	750	0	-1.5
	1	0	1	0	x	x	x	x	750	0	-3.5
	1	0	1	1	x	x	x	x	750	0	-6.0
Output Port Select	x	x	x	x	x	x	0	1	Normal		
	x	x	x	x	x	x	1	1	TEST MODE		
	x	x	x	x	x	x	x	0	Port B = Hi-Z		

TMDS Compliance Test Results

Item	HDMI™ 1.3 Spec	Pericom TMDS Product Spec
Operating Conditions		
Termination Supply Voltage, V_{VDD}	$3.3V \leq 5\%$	$3.30 \pm 5\%$
Terminal Resistance	$50 \text{ Ohm} \leq 10\%$	45 to 55 Ohm
Source DC Characteristics at TP1		
Single-ended high level output voltage, V_H	$A_{VDD} \leq 10mV$	$A_{VDD} \leq 10mV$
Single-ended low level output voltage, V_L	$(A_{VDD} - 600mV) \leq V_L \leq (A_{VDD} - 400mV)$	$(A_{VDD} - 600mV) \leq V_L \leq (A_{VDD} - 400mV)$
Single-ended output swing voltage, V_{swing}	$400mV \leq V_{swing} \leq 600mV$	$400mV \leq V_{swing} \leq 600mV$
Single-ended standby (off) output voltage, V_{off}	$A_{VDD} \pm 10mV$	$A_{VDD} \pm 10mV$
Single-ended standby (off) output current, I_{off}	$ I_{OFF} < 10\mu A$	$ I_{OFF} < 10\mu A$
Transmitter AC Characteristics at TP1		
Risetime/Falltime (20%-80%)	$75ps \leq \text{Risetime/Falltime} \leq 0.4 \text{ Tbit}$ ($75ps \leq tr/ tf \leq 242ps$) @ 1.65Gbps	240ps
Intra-Pair Skew at Transmitter Connector, max	0.15 Tbit (90.9ps @ 1.65Gbps)	60ps max
Inter-Pair Skew at Transmitter Connector, max	0.2 Tpixel (1.2ns @ 1.65Gbps)	100ps max
Clock Jitter, max	0.25 Tbit (151.5ps @ 1.65Gbps)	82ps max
Sink Operating DC Characteristics at TP2		
Input Differential Voltage Level, V_{diff}	$150 \leq V_{diff} \leq 1200mV$	$150mV \leq V_{DIFF} \leq 1200mV$
Input Common Mode Voltage Level, V_{ICM}	$A_{VDD} - 300mV \leq V_{ICM} < A_{VDD} - 37.5mV$ or $A_{VDD} \pm 10\%$	$A_{VDD} - 300mV \leq V_{ICM} < A_{VDD} - 37.5mV$ or $A_{VDD} \pm 10\%$
Sink DC Characteristics When Source Disabled or Disconnected at TP2		
Differential Voltage Level	$A_{VDD} \pm 10mV$	$A_{VDD} \pm 10mV$

DC Electrical Characteristics ($T_A = -40^{\circ}\text{C}$ to $+85^{\circ}\text{C}$, unless otherwise noted. $V_{DD} = 3.3\text{V} \pm 0.3\text{V}$)

Symbol	Parameter	Test Condition ⁽¹⁾	Min.	Typ. ⁽²⁾	Max.	Units
V_H	Single-ended high level output voltage		$V_{DD} - 10\text{mV}$	V_{DD}	$V_{DD} + 10\text{mV}$	V
V_L	Single-ended low level output voltage		$V_{DD} - 600\text{mV}$		$V_{DD} - 400\text{mV}$	V
V_{swing}	Single-ended output swing voltage		400		600	mV
V_{OFF}	Single-ended standby (off) output voltage		$V_{DD} - 10\text{mV}$	V_{DD}	$V_{DD} + 10\text{mV}$	V
I_{OFF}	Single-ended standby (off) output current				10	μs
V_{OS}	Offset Voltage				$V_{DD} - 250\text{mV}$	V
V_{IH}	Minimum Input High Voltage		1.8			V
V_{IL}	Minimum Input Low Voltage				0.8	
I_{CC}	Power Supply Current				280	mA

AC Electrical Characteristics ($T_A = -40^{\circ}\text{C}$ to $+85^{\circ}\text{C}$, $V_{DD} = 3.3\text{V} \pm 0.3\text{V}$)

Symbol	Parameter	Test Conditions ⁽¹⁾	Min.	Typ. ⁽²⁾	Max.	Units
T_{20-80}	Rise time/fall time (20% - 80%)		75		240	ps
	Overshoot				15% of $V_{\text{swing}} * 2$	
	Undershoot				25% of $V_{\text{swing}} * 2$	
	Intra-Pair Skew at Source Connector				60	ps
	Inter-Pair Skew at Connector				100	ps
	Clock duty cycle		40%	50%	60%	
	Through connection impedance		85	100	115	ps
	TMDS differential clock Jitter				82	ps
	At Termination impedance		90	100	110	ps
t_{PHLD}	Differential Propagation Delay High to Low			1.0		ns
t_{PLHD}	Differential Propagation Delay Low to High			1.0		ns
t_{SKD}	Differential Skew $t_{\text{PHLD}} - t_{\text{PLHD}}$			25		ps
t_{PHZ}	Disable Time High to Z			5		ns
t_{PLZ}	Disable Time Low to Z			5		
t_{PZH}	Enable Time Z to High			1		μs
t_{PZL}	Enable Time Z to Low			1		

Notes:

- For Max. or Min. conditions, use appropriate value specified under Electrical Characteristics for the applicable device type.
- Typical values are at $V_{DD} = 3.3\text{V}$, $T_A = 25^{\circ}\text{C}$ ambient and maximum loading.

Power Supply Characteristics

Parameters	Description	Test Conditions ⁽¹⁾	Min.	Typ. ⁽²⁾	Max.	Units
I_{CC}	Quiescent Power Supply Current	$V_{DD} = \text{Max.}, V_{\text{IN}} = V_{DD}, \text{OE} = \text{'LOW'}$		1		mA

Notes:

- For Max. or Min. conditions, use appropriate value specified under Electrical Characteristics for the applicable device type.
- Typical values are at $V_{DD} = 3.3\text{V}$, $T_A = 25^{\circ}\text{C}$ ambient and maximum loading.

TMDS Link Test Points

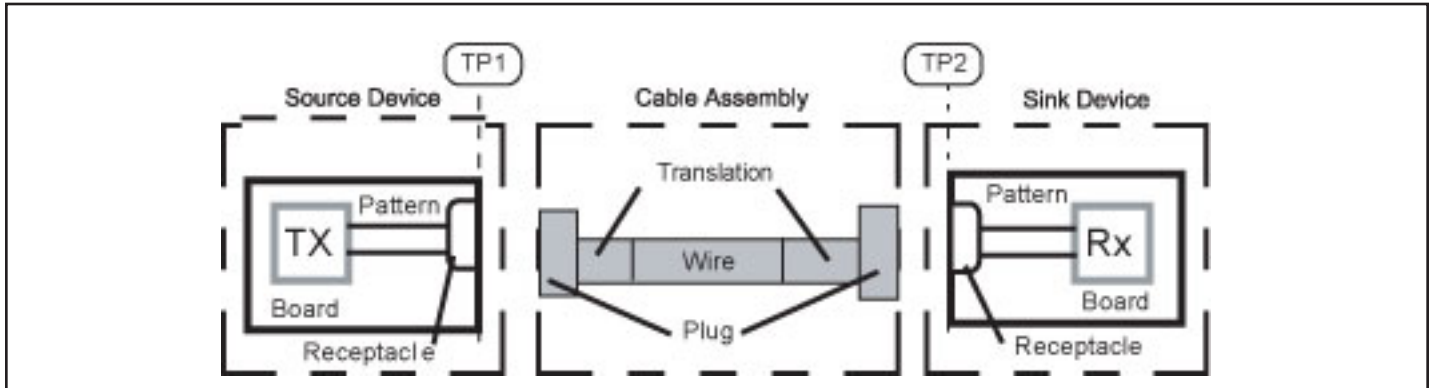

Normalized Eye Diagram Mask at TP1 for Source Requirements

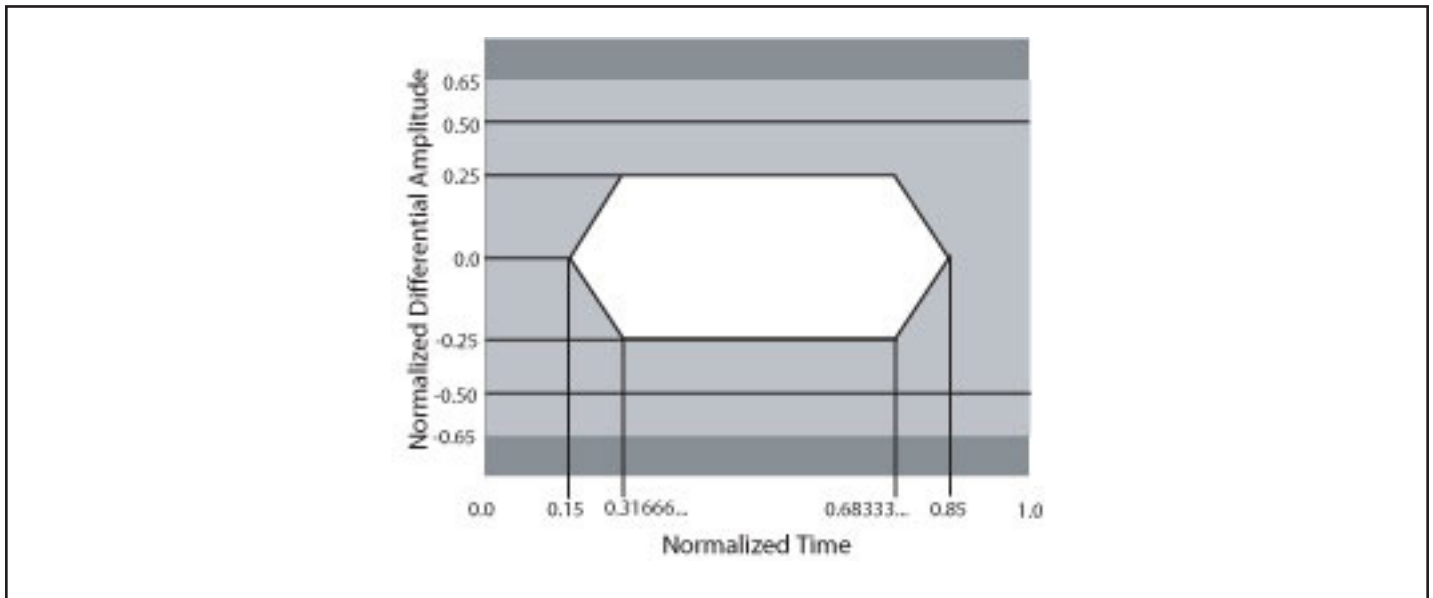

Absolute Eye Diagram Mask at TP2 for Sink Requirements

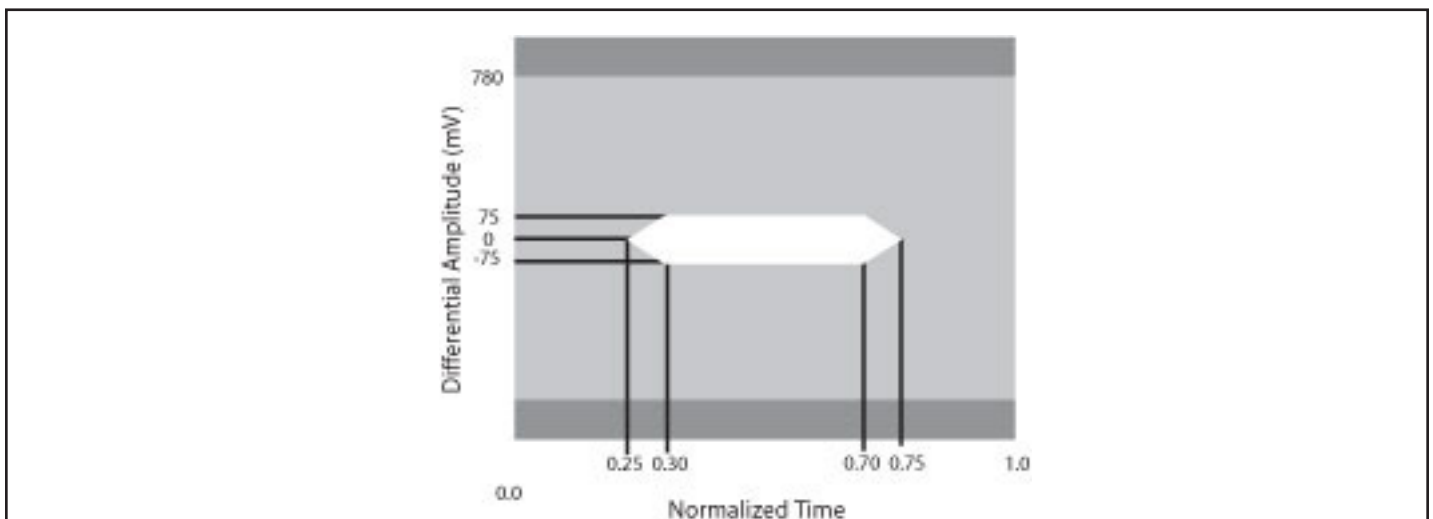

Application Information (Please see application note for important design information.)

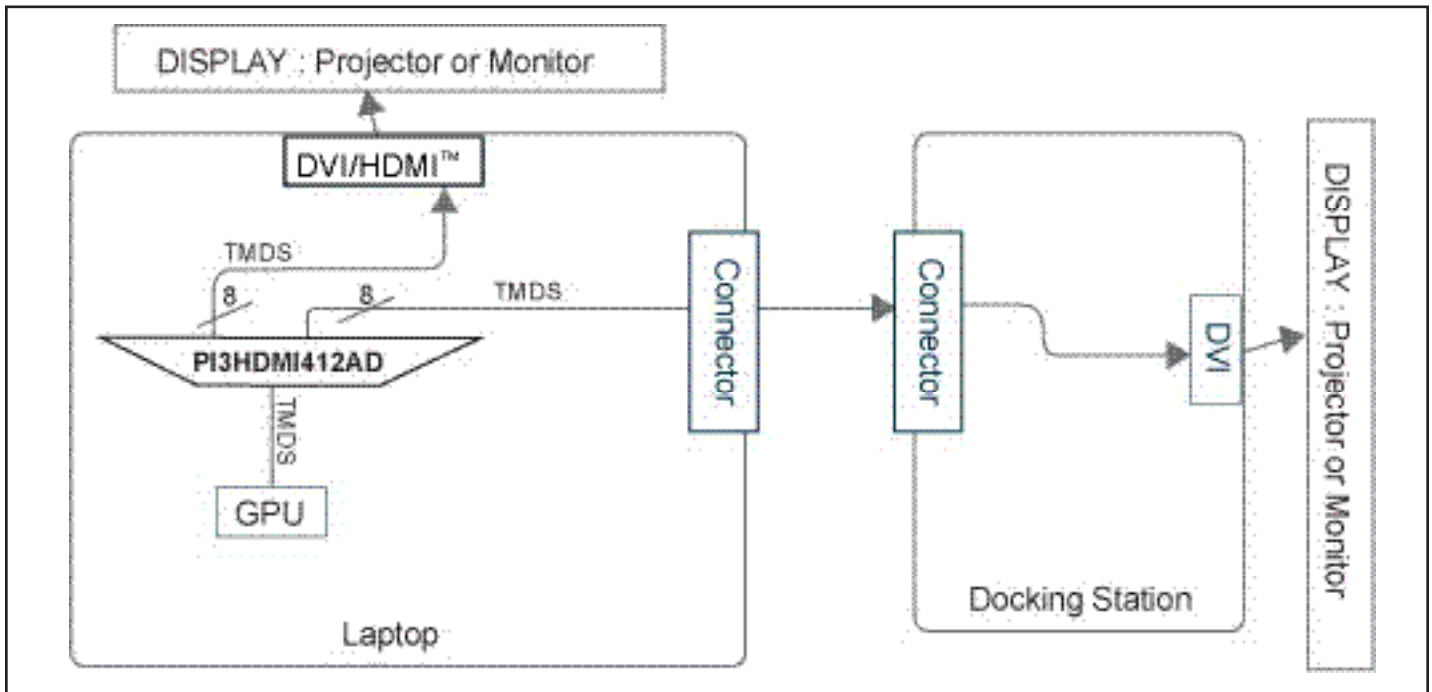

DVI TP2 (Tx) Compliance Test Setup

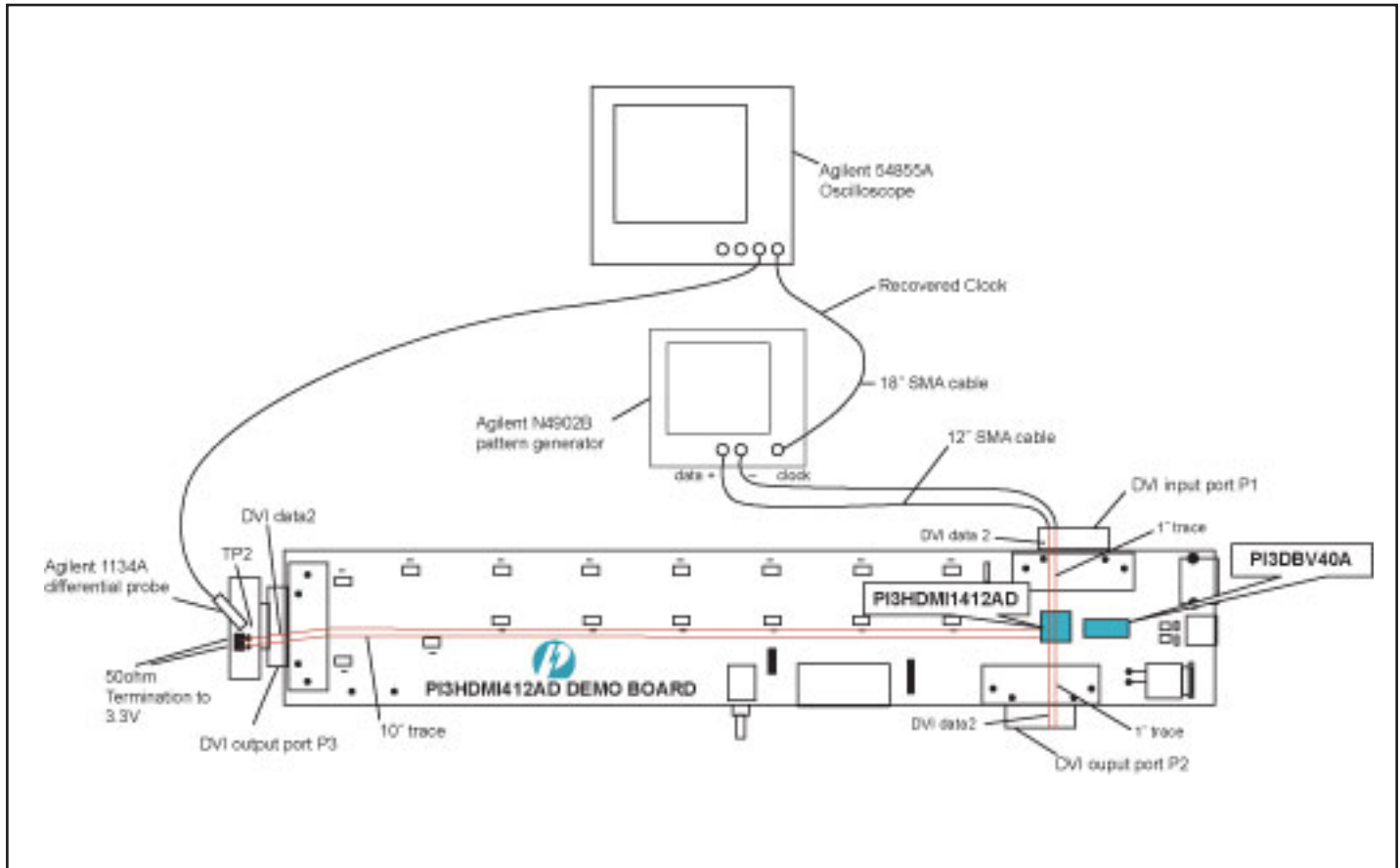

Pre-Emphasis Validation

Measured at output DVI port, P3; Right eye is with pre-emphasis, left eye is without pre-emphasis

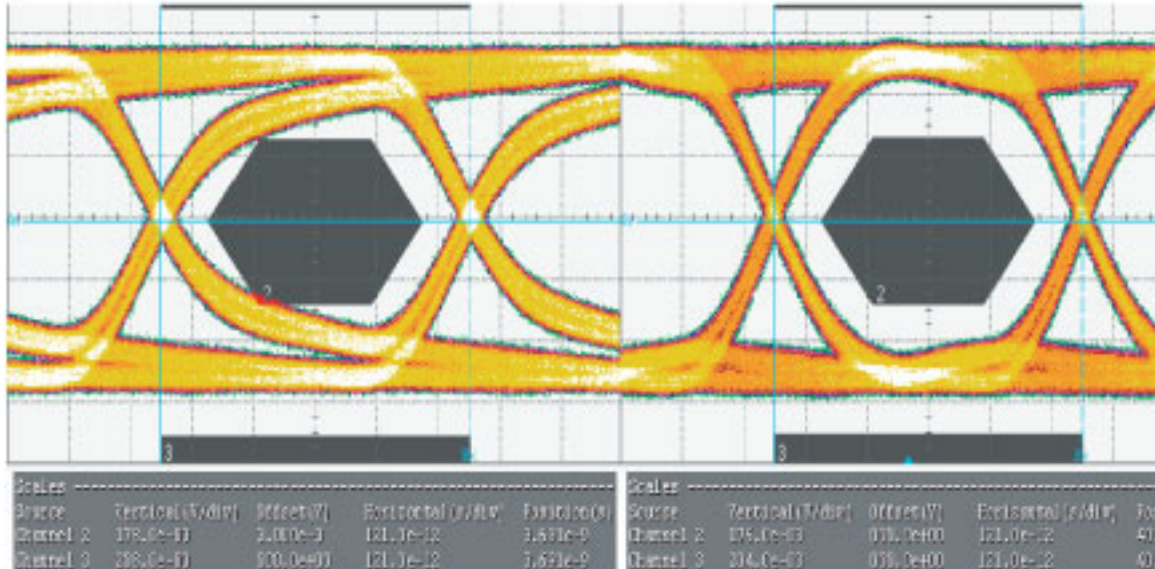

De-Emphasis Validation

Measured at output DVI port, P3; Right eye is with de-emphasis, left eye is without de-emphasis

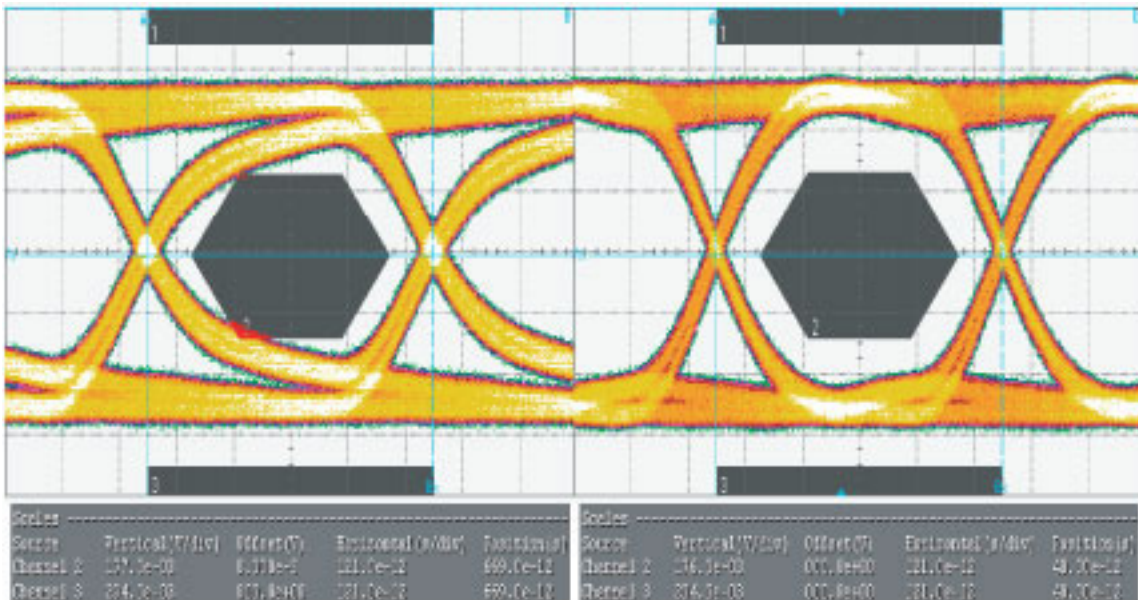

Package Mechanical: 56-pad, TQFN (ZB56)

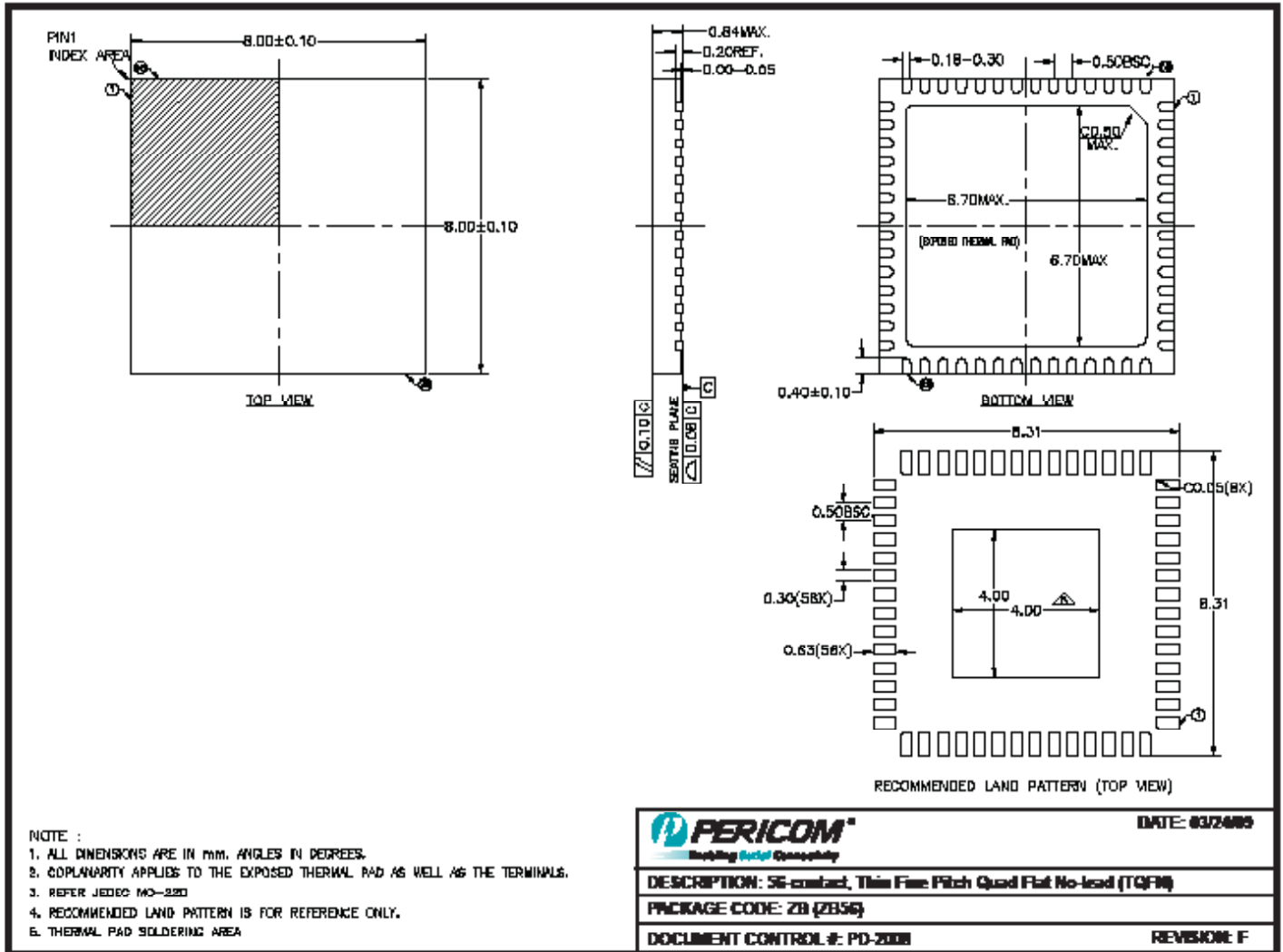

DS-0171

Note:

- For latest package info, please check: <http://www.pericom.com/products/packaging/mechanicals.php>

Ordering Information

Ordering Code	Package Code	Package Description
PI3HDMI412ADZBE	ZB	56-pin, Pb-free & Green TQFN

Notes:

- Thermal characteristics can be found on the company web site at www.pericom.com/packaging/
- E = Pb-free and Green
- Adding an X Suffix = Tape/Reel

HDMI Licensing, LLC, a wholly owned subsidiary of Silicon Image, Inc., is the agent responsible for licensing the HDMI Specification, promoting the HDMI standard and providing education on the benefits of HDMI to retailers and consumers. The HDMI Specification was developed by Sony, Hitachi, Thomson (RCA), Philips, Matsushita (Panasonic), Toshiba and Silicon Image as the digital interface standard for the consumer electronics market. The HDMI specification combines uncompressed high-definition video and multi-channel audio in a single digital interface to provide crystal-clear digital quality over a single cable.

For more information about HDMI, please visit www.hdmi.org

IMPORTANT NOTICE

1. DIODES INCORPORATED (Diodes) AND ITS SUBSIDIARIES MAKE NO WARRANTY OF ANY KIND, EXPRESS OR IMPLIED, WITH REGARDS TO ANY INFORMATION CONTAINED IN THIS DOCUMENT, INCLUDING, BUT NOT LIMITED TO, THE IMPLIED WARRANTIES OF MERCHANTABILITY, FITNESS FOR A PARTICULAR PURPOSE OR NON-INFRINGEMENT OF THIRD PARTY INTELLECTUAL PROPERTY RIGHTS (AND THEIR EQUIVALENTS UNDER THE LAWS OF ANY JURISDICTION).

2. The Information contained herein is for informational purpose only and is provided only to illustrate the operation of Diodes' products described herein and application examples. Diodes does not assume any liability arising out of the application or use of this document or any product described herein. This document is intended for skilled and technically trained engineering customers and users who design with Diodes' products. Diodes' products may be used to facilitate safety-related applications; however, in all instances customers and users are responsible for (a) selecting the appropriate Diodes products for their applications, (b) evaluating the suitability of Diodes' products for their intended applications, (c) ensuring their applications, which incorporate Diodes' products, comply the applicable legal and regulatory requirements as well as safety and functional-safety related standards, and (d) ensuring they design with appropriate safeguards (including testing, validation, quality control techniques, redundancy, malfunction prevention, and appropriate treatment for aging degradation) to minimize the risks associated with their applications.

3. Diodes assumes no liability for any application-related information, support, assistance or feedback that may be provided by Diodes from time to time. Any customer or user of this document or products described herein will assume all risks and liabilities associated with such use, and will hold Diodes and all companies whose products are represented herein or on Diodes' websites, harmless against all damages and liabilities.

4. Products described herein may be covered by one or more United States, international or foreign patents and pending patent applications. Product names and markings noted herein may also be covered by one or more United States, international or foreign trademarks and trademark applications. Diodes does not convey any license under any of its intellectual property rights or the rights of any third parties (including third parties whose products and services may be described in this document or on Diodes' website) under this document.

5. Diodes' products are provided subject to Diodes' Standard Terms and Conditions of Sale (<https://www.diodes.com/about/company/terms-and-conditions/terms-and-conditions-of-sales/>) or other applicable terms. This document does not alter or expand the applicable warranties provided by Diodes. Diodes does not warrant or accept any liability whatsoever in respect of any products purchased through unauthorized sales channel.

6. Diodes' products and technology may not be used for or incorporated into any products or systems whose manufacture, use or sale is prohibited under any applicable laws and regulations. Should customers or users use Diodes' products in contravention of any applicable laws or regulations, or for any unintended or unauthorized application, customers and users will (a) be solely responsible for any damages, losses or penalties arising in connection therewith or as a result thereof, and (b) indemnify and hold Diodes and its representatives and agents harmless against any and all claims, damages, expenses, and attorney fees arising out of, directly or indirectly, any claim relating to any noncompliance with the applicable laws and regulations, as well as any unintended or unauthorized application.

7. While efforts have been made to ensure the information contained in this document is accurate, complete and current, it may contain technical inaccuracies, omissions and typographical errors. Diodes does not warrant that information contained in this document is error-free and Diodes is under no obligation to update or otherwise correct this information. Notwithstanding the foregoing, Diodes reserves the right to make modifications, enhancements, improvements, corrections or other changes without further notice to this document and any product described herein. This document is written in English but may be translated into multiple languages for reference. Only the English version of this document is the final and determinative format released by Diodes.

8. Any unauthorized copying, modification, distribution, transmission, display or other use of this document (or any portion hereof) is prohibited. Diodes assumes no responsibility for any losses incurred by the customers or users or any third parties arising from any such unauthorized use.

9. This Notice may be periodically updated with the most recent version available at <https://www.diodes.com/about/company/terms-and-conditions/important-notice>

The Diodes logo is a registered trademark of Diodes Incorporated in the United States and other countries.

All other trademarks are the property of their respective owners.

© 2023 Diodes Incorporated. All Rights Reserved.

www.diodes.com