

**Digital Video Level Shifter from AC Coupled Digital Video Input to a DVI/HDMI™ Transmitter**

**Features**

- Converts low-swing AC coupled differential input to HDMI™ rev 1.3 compliant open-drain current steering Rx terminated differential output
- HDMI level shifting operation up to 2.5Gbps per lane (250MHz pixel clock)
- Integrated 50-ohm termination resistors for AC-coupled differential inputs.
- Enable/Disable feature to turn off TMDS outputs to enter low-power state.
- Output slew rate control on TMDS outputs to minimize EMI.
- Transparent operation: no re-timing or configuration required.
- 3.3 Power supply required.
- Integrated ESD protection to 8kV contact on all high speed I/O pins (IN\_x and OUT\_x) per IEC61000-4-2 test spec, level 4
- DDC level shifters from 5V from sink side down to 3.3V on source side
- Level shifter for HPD signal from HDMI/DVI connector
- Integrated pull-down on HPD\_sink input guarantees "input low" when no display is plugged in
- Packaging (Pb-Free & Green)
  - – 48 TQFN, 7mm x 7mm (ZB)

**Description**

Pericom Semiconductor's PI3VDP411LS provides the ability to use a Dual-mode DP transmitter in HDMI™ mode. This flexibility provides the user a choice of how to connect to their favorite display. All signal paths accept AC coupled video signals. The PI3VDP411LS converts this AC coupled signal into an HDMI rev 1.3 compliant signal with proper signal swing. This conversion is automatic and transparent to the user.

The PI3VDP411LS supports up to 2.5Gbps, which provides 12-bits of color depth per channel, as indicated in HDMI rev 1.3.

**Pin Configuration 48-Pin TQFN (ZB)**

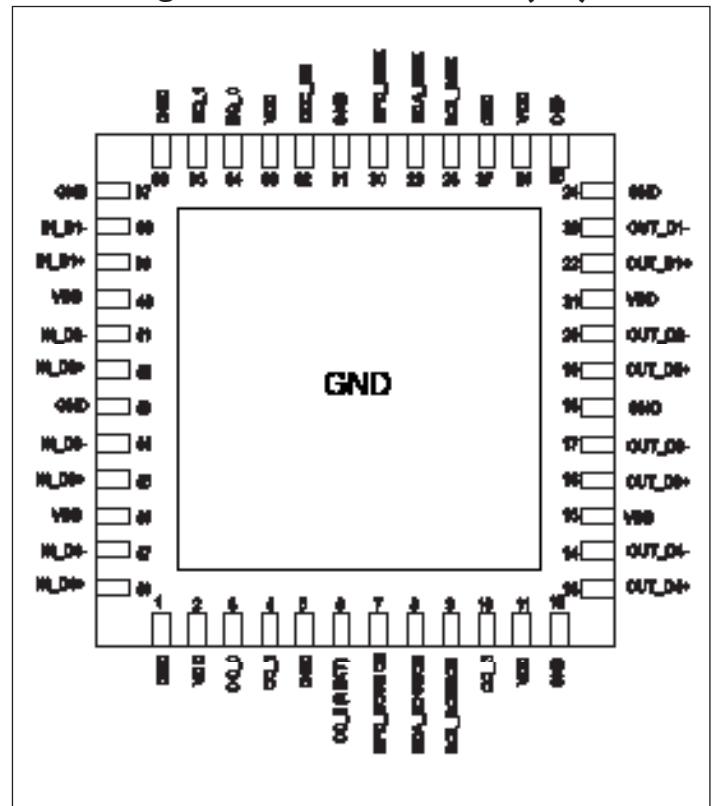

**Block Diagram**

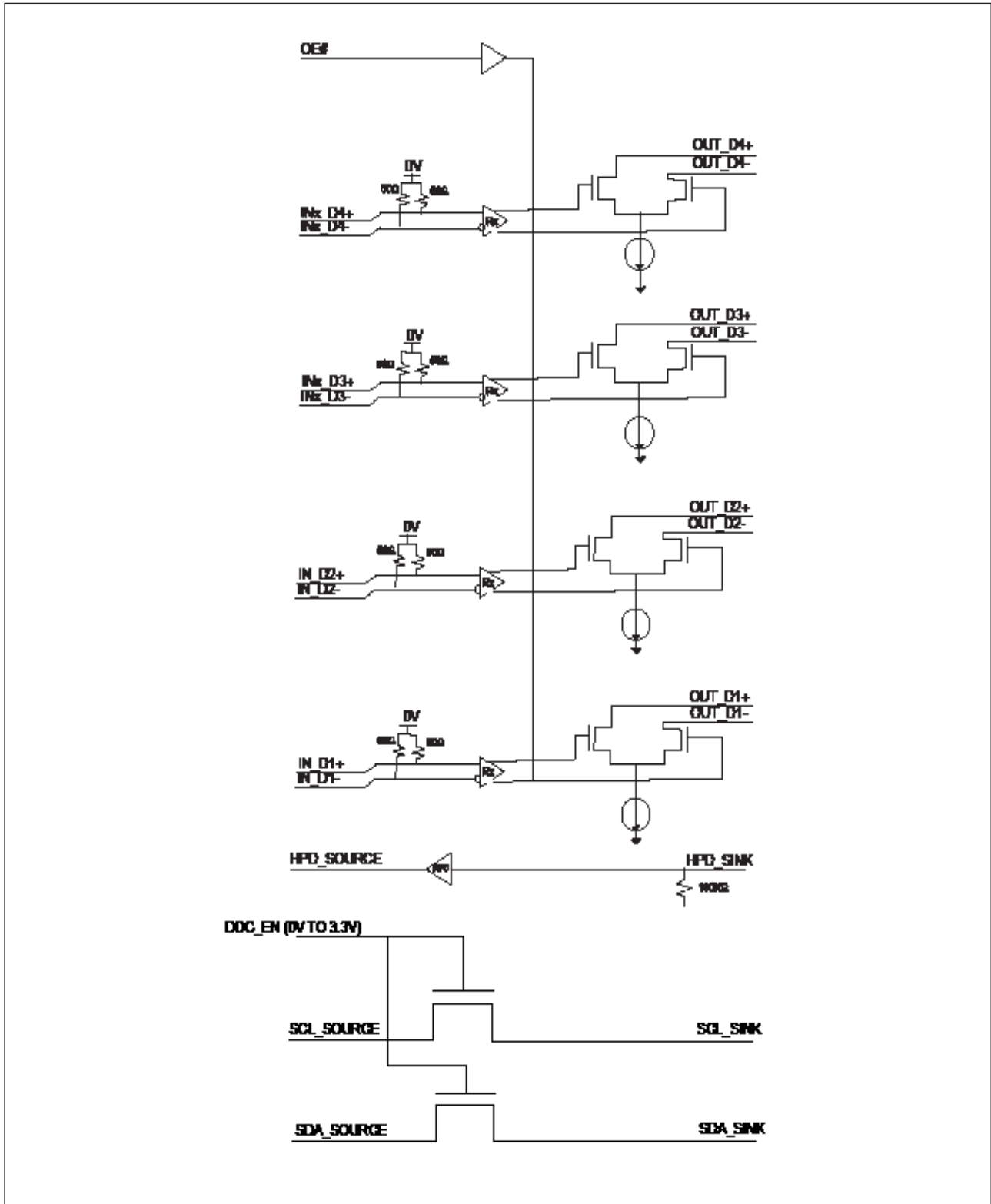

**Maximum Ratings** (Above which useful life may be impaired. For user guidelines, not tested.)

Storage Temperature.....	-65°C to +150°C
Supply Voltage to Ground Potential.....	-0.5V to +5V
DC Input Voltage.....	-0.5V to V <sub>DD</sub>
DC Output Current .....	120mA
Power Dissipation .....	1.0W

**Note:** Stresses greater than those listed under MAXIMUM RATINGS may cause permanent damage to the device. This is a stress rating only and functional operation of the device at these or any other conditions above those indicated in the operational sections of this specification is not implied. Exposure to absolute maximum rating conditions for extended periods may affect reliability.

**Table 2: Signal Descriptions**

Pin Name	Type	Description									
OE#	5.5V tolerant low-voltage single-ended input	Enable for level shifter path									
		<table border="1"> <thead> <tr> <th>OE#</th> <th>IN_D Termination</th> <th>OUT_D Outputs</th> </tr> </thead> <tbody> <tr> <td>1</td> <td>&gt;100KΩ</td> <td>High-Z</td> </tr> <tr> <td>0</td> <td>50Ω</td> <td>Active</td> </tr> </tbody> </table>	OE#	IN_D Termination	OUT_D Outputs	1	>100KΩ	High-Z	0	50Ω	Active
		OE#	IN_D Termination	OUT_D Outputs							
		1	>100KΩ	High-Z							
0	50Ω	Active									
IN_D4+	Differential input	Low-swing diff input from GMCH PCIE outputs. IN_D4+ makes a differential pair with IN_D4-.									
IN_D4-	Differential input	Low-swing diff input from GMCH PCIE outputs. IN_D4- makes a differential pair with IN_D4+.									
IN_D3+	Differential input	Low-swing diff input from GMCH PCIE outputs. IN_D3+ makes a differential pair with IN_D3-.									
IN_D3-	Differential input	Low-swing diff input from GMCH PCIE outputs. IN_D3- makes a differential pair with IN_D3+.									
IN_D2+	Differential input	Low-swing diff input from GMCH PCIE outputs. IN_D2+ makes a differential pair with IN_D2-.									
IN_D2-	Differential input	Low-swing diff input from GMCH PCIE outputs. IN_D2- makes a differential pair with IN_D2+.									
IN_D1+	Differential input	Low-swing diff input from GMCH PCIE outputs. IN_D1+ makes a differential pair with IN_D1-.									
IN_D1-	Differential input	Low-swing diff input from GMCH PCIE outputs. IN_D1- makes a differential pair with IN_D1+.									
OUT_D4+	TMDS Differential output	HDMI 1.3 compliant TMDS output. OUT_D4+ makes a differential output signal with OUT_D4-.									
OUT_D4-	TMDS Differential output	HDMI 1.3 compliant TMDS output. OUT_D4- makes a differential output signal with OUT_D4+.									
OUT_D3+	TMDS Differential output	HDMI 1.3 compliant TMDS output. OUT_D3+ makes a differential output signal with OUT_D3-.									
OUT_D3-	TMDS Differential output	HDMI 1.3 compliant TMDS output. OUT_D3- makes a differential output signal with OUT_D3+.									

(Continued)

Pin Name	Type	Description						
OUT_D2+	TMDS Differential output	HDMI 1.3 compliant TMDS output. OUT_D2+ makes a differential output signal with OUT_D2-.						
OUT_D2-	TMDS Differential output	HDMI 1.3 compliant TMDS output. OUT_D2- makes a differential output signal with OUT_D2+.						
OUT_D1+	TMDS Differential output	HDMI 1.3 compliant TMDS output. OUT_D1+ makes a differential output signal with OUT_D1-.						
OUT_D1-	TMDS Differential output	HDMI 1.3 compliant TMDS output. OUT_D1- makes a differential output signal with OUT_D1+.						
HPD_SINK	5V tolerance single-ended input	Low Frequency, 0V to 5V (nominal) input signal. This signal comes from the HDMI connector. Voltage High indicates "plugged" state; voltage low indicated "unplugged". HPD_SINK is pulled down by an integrated 100K ohm put-down resistor.						
HPD_SOURCE	3.3V single-ended output	HPD_SOURCE: 0V to 3.3V (nominal) output signal. This is level-shifted version of the HPD_SINK signal.						
SCL_SOURCE	Single-ended 3.3V open-drain DDC I/O	3.3V DDC Data I/O. Pulled up by external termination to 3.3V. Connected to SCL_SINK through voltage-limiting integrated NMOS passgate.						
SDA_SOURCE	Single-ended 3.3V open-drain DDC I/O	3.3V DDC Data I/O. Pulled up by external termination to 3.3V. Connected to SDA_SINK through voltage-limiting integrated NMOS passgate.						
SCL_SINK	Single-ended 5V open-drain DDC I/O	5V DDC Clock I/O. Pulled up by external termination to 5V. Connected to SCL_SOURCE through voltage-limiting integrated NMOS passgate.						
SDA_SINK	Single-ended 5V open-drain DDC I/O	5V DDC Data I/O. Pulled up by external termination to 5V. Connected to SDA_SOURCE through voltage-limiting integrated NMOS passgate.						
DDC_EN	5.0V tolerant Single-ended input	Enables bias voltage to the DDC passgate level shifter gates. (May be implemented as a bias voltage connection to the DDC pass gates themselves.) <table border="1" style="margin-left: auto; margin-right: auto;"> <tr> <td>DDC_EN</td> <td>Passgate</td> </tr> <tr> <td>0V</td> <td>Disabled</td> </tr> <tr> <td>3.3V</td> <td>Enabled</td> </tr> </table>	DDC_EN	Passgate	0V	Disabled	3.3V	Enabled
DDC_EN	Passgate							
0V	Disabled							
3.3V	Enabled							
VDD	3.3V DC Supply	3.3V ± 10%						
OC_2 (REXT)	3.3V single-ended control input	Acceptable connections to OC_1 (REXT) pin are: Resistor to GND; Resistor to 3.3V; NC. (Resistor should be 0-ohm).						

Pin Name	Type	Description
OC_3	Analog connection to external component or supply	Acceptable connections to OC_3 pin are: short to 3.3V or to GND; NC.
OC_0 OC_1 EQ_0 EQ_1	Output and Input jitter elimination control	Control pins are to enable Jitter elimination features. For normal operation these pins are tied GND or to VDD. Please see the truth tables for more information.

**Truth Table 1**

OC_3 <sup>(2)</sup>	OC_2 <sup>(1)</sup>	OC_1 <sup>(1)</sup>	OC_0 <sup>(1)</sup>	Vswing (mV)	Pre/De-emphasis
0	0	0	0	500	0
0	0	0	1	600	0
0	0	1	0	750	0
0	0	1	1	1000	0
0	1	0	0	500	0
0	1	0	1	500	1.5dB
0	1	1	0	500	3.5dB
0	1	1	1	500	6dB
1	0	0	0	400	0
1	0	0	1	400	3.5dB
1	0	1	0	400	6dB
1	0	1	1	400	9dB
1	1	0	0	1000	0
1	1	0	1	1000	-3.5dB
1	1	1	0	1000	-6dB
1	1	1	1	1000	-9dB

**Truth Table 2**

EQ_1 <sup>(2)</sup>	EQ_0 <sup>(1)</sup>	Equalization @ 1.25GHz (dB)
0	0	3
0	1	6
1	0	9
1	1	12

**Notes:**

- 1) These signals have internal 100kΩ pull-ups.
- 2) For 48-TQFN package, these signals have internal 100kΩ pull-ups, with external connection.

## Electrical Characteristics

**Table 3: Power Supplies and Temperature Range**

Symbol	Parameter	Min	Nom	Max	Units	Comments
V <sub>DD</sub>	3.3V Power Supply	3.0	3.3	3.6	V	
I <sub>CC</sub>	Max Current			100	mA	Total current from V <sub>DD</sub> 3.3V supply when de-emphasis/pre-emphasis is set to 0dB.
I <sub>CCQ</sub>	Standby Current Consumption			2	mA	OE# = HIGH
T <sub>CASE</sub>	Case temperature range for operation with spec.	-40		85	Celcius	

**Table 4: OE# Description**

OE#	Device State	Comments
Asserted (low voltage)	Differential input buffers and output buffers enabled. Input impedance = 50Ω	Normal functioning state for IN_D to OUT_D level shifting function.
Unasserted (high voltage)	<p>Low-power state.</p> <p>Differential input buffers and termination are disabled. Differential inputs are in a high-impedance state.</p> <p>OUT_D level-shifting outputs are disabled. OUT_D level-shifting outputs are in high-impedance state.</p> <p>Internal bias currents are turned off.</p>	<p>Intended for lowest power condition when:</p> <ul style="list-style-type: none"> <li>• No display is plugged in or</li> <li>• The level shifted data path is disabled</li> </ul> <p>HPD_SINK input and HPD_SOURCE output are not affected by OE# SCL_SOURCE, SCL_SINK, SDA_SOURCE and SDA_SINK signals and functions are not affected by OE#</p>

**Table 5: Differential Input Characteristics for IN\_D and RX\_IN signals**

Symbol	Parameter	Min	Nom	Max	Units	Comments
Tbit	Unit Interval	360			ps	Tbit is determined by the display mode. Nominal bit rate ranges from 250Mbps to 2.5Gbps per lane. Nominal Tbit at 2.5 Gbps=400ps. 360ps=400ps-10%
V <sub>RX-DIFFp-p</sub>	Differential Input Peak to Peak Voltage	0.175		1.200	V	$VRX-DIFFp-p=2 VRX-D+ \times VRX-D- $ Applies to IN_D and RX_IN signals
T <sub>RX-EYE</sub>	Minimum Eye Width at IN_D input pair	0.8			Tbit	The level shifter may add a maximum of 0.02UI jitter
V <sub>CM-AC-pp</sub>	AC Peak Common Mode Input Voltage			100	mV	$VCM-AC-pp =  VRX-D+ + VRX-D- /2 - VRX-CM-DC$ . $VRX-CM-DC = DC(avg) \text{ of }  VRX-D+ + VRX-D- /2$ VCM-AC-pp includes all frequencies above 30 kHz.
Z <sub>RX-DC</sub>		40	50	60	Ω	Required IN_D+ as well as IN_D- DC impedance (50Ω ± 20% tolerance).
V <sub>RX-Bias</sub>		0		2.0	V	Intended to limit power-up stress on chipset's PCIE output buffers.
Z <sub>RX-HIGH-Z</sub>		100			kΩ	Differential inputs must be in a high impedance state when OE# is HIGH.

## TMDS Outputs

The level shifter's TMDS outputs are required to meet HDMI 1.3 specifications.

The HDMI 1.3 Specification is assumed to be the correct reference in instances where this document conflicts with the HDMI 1.3 specification.

**Table 6: Differential Output Characteristics for TMDS\_OUT signals**

Symbol	Parameter	Min	Nom	Max	Units	Comments
V <sub>H</sub>	Single-ended high level output voltage	V <sub>DD</sub> -10mV	V <sub>DD</sub>	V <sub>DD</sub> +10mV	V	V <sub>DD</sub> is the DC termination voltage in the HDMI or DVI Sink. V <sub>DD</sub> is nominally 3.3V
V <sub>L</sub>	Single-ended low level output voltage	V <sub>DD</sub> -600mV	V <sub>DD</sub> -500mV	V <sub>DD</sub> -400mV	V	The open-drain output pulls down from V <sub>DD</sub> .
V <sub>SWING</sub>	Single-ended output swing voltage	450mV	500mV	600mV	V	Swing down from TMDS termination voltage (3.3V ± 10%)
I <sub>OFF</sub>	Single-ended current in high-Z state			50	μA	Measured with TMDS outputs pulled up to V <sub>DD</sub> Max_(3.6V) through 50Ω resistors.
T <sub>R</sub>	Rise time	125ps		0.4Tbit	ps	Max Rise/Fall time @2.7Gbps = 148ps. 125ps = 148-15%
T <sub>F</sub>	Fall time	125ps		0.4Tbit	ps	Max Rise/Fall time @2.7Gbps = 148ps. 125ps = 148-15%
T <sub>SKEW-INTRA</sub>	Intra-pair differential skew			30	ps	This differential skew budget is in addition to the skew presented between D+ and D- paired input pins. HDMI revision 1.3 source allowable intra-pair skew is 0.15Tbit.
T <sub>SKEW-INTER</sub>	Inter-pair lane-to-lane output skew			100	ps	This lane-to-lane skew budget is in addition to skew between differential input pairs
T <sub>JIT</sub>	Jitter added to TMDS signals			25	ps	Jitter budget for TMDS signals as they pass through the level shifter. 25ps = 0.056 Tbit at 2.25 Gb/s



### TMDS Output Oscillation Elimination

The inputs do not incorporate a squelch circuit. Therefore, we recommend the input to be externally biased to prevent output oscillation. Pericom recommends to add a 1.5Kohm pull-up to the CLK- input.

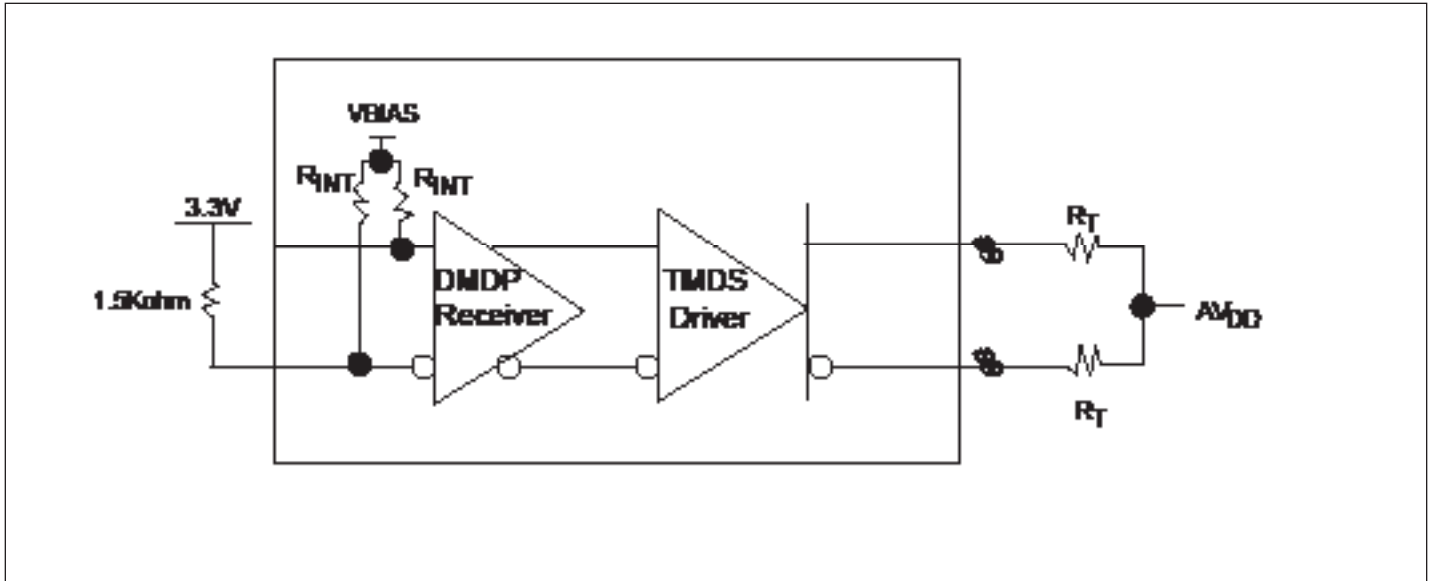

### TMDS Input Fail-Safe Recommendation

**Table 8: HPD Input Characteristics**

Symbol	Parameter	Min	Nom	Max	Units	Comments
V <sub>IH-HPD</sub>	Input High Level	2.0	5.0	5.3	V	Low-speed input changes state on cable plug/unplug
V <sub>IL-HPD</sub>	HPD_sink Input Low Level	0		0.8	V	
I <sub>IN-HPD</sub>	HPD_sink Input Leakage Current			70	μA	Measured with HPD_sink at V <sub>IH-HPD</sub> max and V <sub>IL-HPD</sub> min
V <sub>OH-HPDB</sub>	HPD_sink Output High-Level	2.5		V <sub>DD</sub>	V	V <sub>DD</sub> = 3.3V ± 10%
V <sub>OL-HPDB</sub>	HPD_sink Output Low-Level	0		0.02	V	
T <sub>HPD</sub>	HPD_sink to HPD_source propagation delay			200	ns	Time from HPD_sink changing state to HPD_source changing state. Includes HPD_source rise/fall time
T <sub>RF-HPDB</sub>	HPD_source rise/fall time	1		20	ns	Time required to transition from V <sub>OH-HPDB</sub> to V <sub>OL-HPDB</sub> or from V <sub>OL-HPDB</sub> to V <sub>OH-HPDB</sub>

**Table 9: OE# Input and DDC\_EN**

Symbol	Parameter	Min	Nom	Max	Units	Comments
V <sub>IH</sub>	Input High Level	2.0		V <sub>DD</sub>	V	TMDS enable input changes state on cable plug/unplug
V <sub>IL</sub>	Input Low Level	0		0.8	V	
I <sub>IN</sub>	Input Leakage Current			10	μA	Measured with input at V <sub>IH-EN</sub> max and V <sub>IL-EN</sub> min

**Table 10: Termination Resistors**

Symbol	Parameter	Min	Nom	Max	Units	Comments
R <sub>HPD</sub>	HPD_sink input pull-down resistor.	80K	100k	120K	Ω	Guarantees HPD_sink is LOW when no display is plugged in.

### Recommended Power Supply Decoupling Circuit

Figure 1 is the recommended power supply decoupling circuit configuration. It is recommended to put 0.1µF decoupling capacitors on each VDD pins of our part, there are four 0.1µF decoupling capacitors are put in Figure 1 with an assumption of only four VDD pins on our part, if there is more or less VDD pins on our Pericom parts, the number of 0.1µF decoupling capacitors should be adjusted according to the actual number of VDD pins. On top of 0.1µF decoupling capacitors on each VDD pins, it is recommended to put a 10µF decoupling capacitor near our part's VDD, it is for stabilizing the power supply for our part. Ferrite bead is also recommended for isolating the power supply for our part and other power supplies in other parts of the circuit. But, it is optional and depends on the power supply conditions of other circuits.

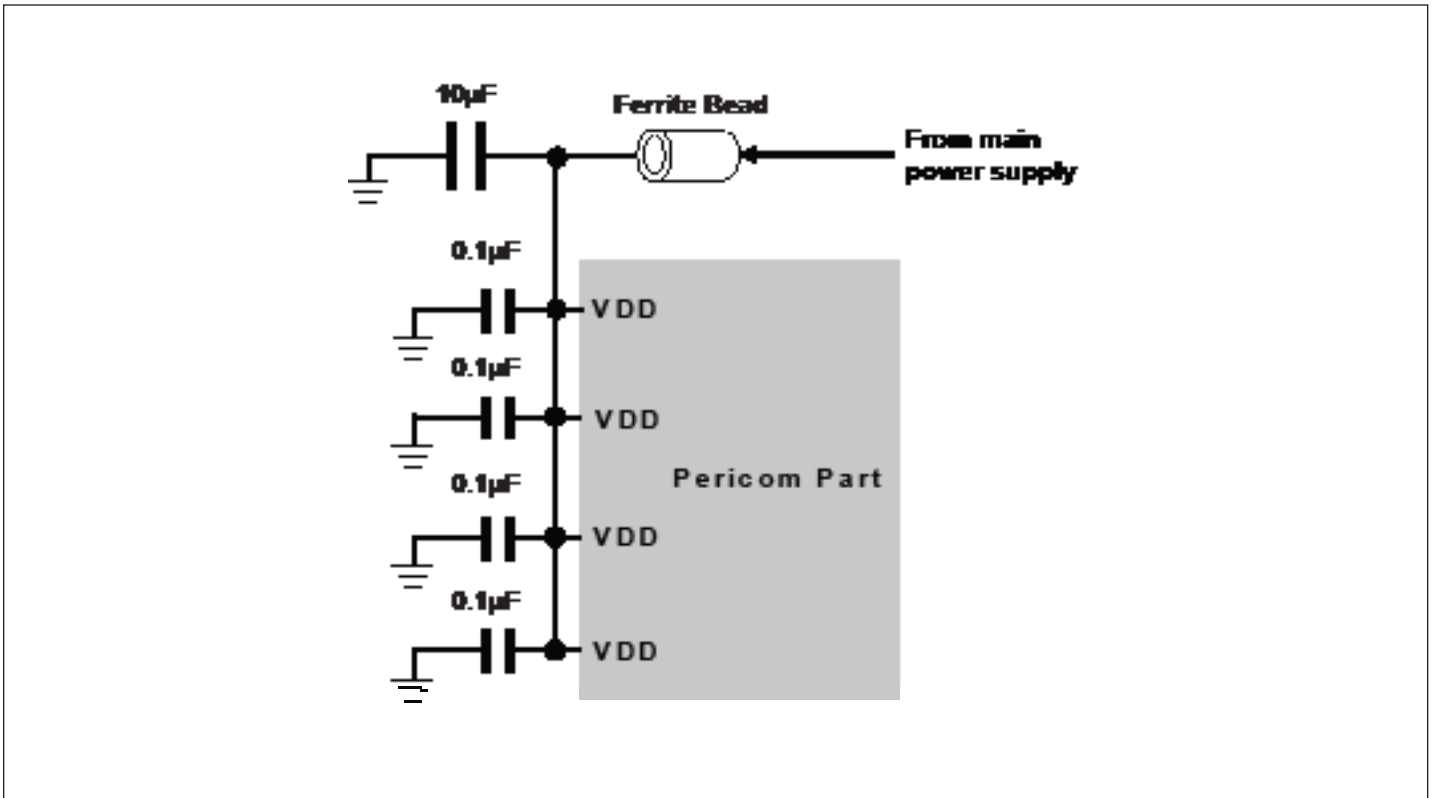

**Figure 1 Recommended Power Supply Decoupling Circuit Diagram**

## Requirements on the Decoupling Capacitors

There is no special requirement on the material of the capacitors. Ceramic capacitors are generally being used with typically materials of X5R or X7R.

## Layout and Decoupling Capacitor Placement Consideration

- i. Each 0.1μF decoupling capacitor should be placed as close as possible to each V<sub>DD</sub> pin.
- ii. V<sub>DD</sub> and GND planes should be used to provide a low impedance path for power and ground.
- iii. Via holes should be placed to connect to V<sub>DD</sub> and GND planes directly.
- iv. Trace should be as wide as possible
- v. Trace should be as short as possible.
- vi. The placement of decoupling capacitor and the way of routing trace should consider the power flowing criteria.
- vii. 10μF capacitor should also be placed closed to our part and should be placed in the middle location of 0.1μF capacitors.
- viii. Avoid the large current circuit placed close to our part; especially when it is shared the same V<sub>DD</sub> and GND planes. Since large current flowing on our V<sub>DD</sub> or GND planes will generate a potential variation on the V<sub>DD</sub> or GND of our part.

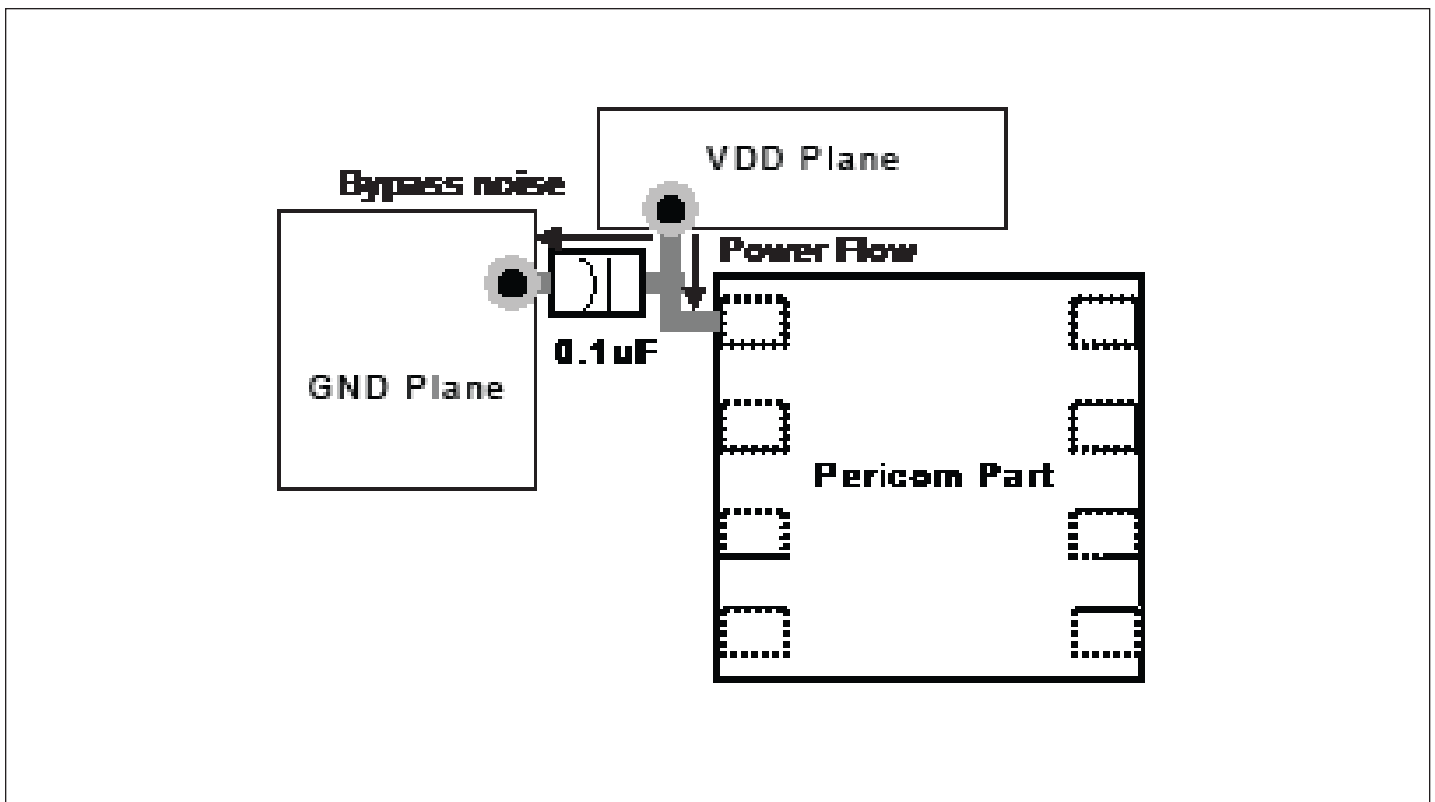

Figure 2 Layout and Decoupling Capacitor Placement Diagram

## Packaging Mechanical: 48-contact TQFN (ZB)

SYMBOLS	MIN.	NOM.	MAX.
A	0.80	0.90	1.00
A1	0.00	0.02	0.05
A2	0.65 REF.		
A3	0.203 REF.		
b	0.18	0.25	0.30
h	0.24	0.42	0.60
D	6.90	7.00	7.10
D1	6.65	6.75	6.85
E	6.90	7.00	7.10
E1	6.65	6.75	6.85
e	0.50 BSC.		
K	0.20	—	—
L	0.30	0.40	0.50
θ*	0.00	—	12.00

UNIT : mm

PAD SIZE	D2			E2		
	MIN.	NOM.	MAX.	MIN.	NOM.	MAX.
157X157MIL	3.40	3.60	3.80	3.40	3.60	3.80
213X213MIL	5.00	5.20	5.40	5.00	5.20	5.40
208X208MIL	4.90	5.10	5.30	4.90	5.10	5.30

UNIT: mm

**Notes:**

1. All dimensions are in millimeters, angles are in degrees.
2. Coplanarity applies to the exposed thermal pad as well as the terminals.
3. Refer JEDEC MO-220

DATE: 03/09/12

**DESCRIPTION: 48-Pin, Thin Fine Pitch Quad Flat No-Lead (TQFN)**

**PACKAGE CODE: ZB48**

**DOCUMENT CONTROL #: PD-2080** **REVISION: B**

12-0459

For latest package info, please check: <http://www.pericom.com/products/packaging/mechanicals.php>

## Ordering Information

Ordering Code	Package Code	Package Description
PI3VDP411LSZBEX	ZB	48-contact, Thin Fine Pitch Quad Flat No-Lead (TQFN)

**Notes:**

- Thermal characteristics can be found on the company web site at [www.pericom.com/packaging/](http://www.pericom.com/packaging/)
- E = Pb-free and Green
- Adding an X Suffix = Tape/Reel

**IMPORTANT NOTICE**

1. DIODES INCORPORATED (Diodes) AND ITS SUBSIDIARIES MAKE NO WARRANTY OF ANY KIND, EXPRESS OR IMPLIED, WITH REGARDS TO ANY INFORMATION CONTAINED IN THIS DOCUMENT, INCLUDING, BUT NOT LIMITED TO, THE IMPLIED WARRANTIES OF MERCHANTABILITY, FITNESS FOR A PARTICULAR PURPOSE OR NON-INFRINGEMENT OF THIRD PARTY INTELLECTUAL PROPERTY RIGHTS (AND THEIR EQUIVALENTS UNDER THE LAWS OF ANY JURISDICTION).

2. The Information contained herein is for informational purpose only and is provided only to illustrate the operation of Diodes' products described herein and application examples. Diodes does not assume any liability arising out of the application or use of this document or any product described herein. This document is intended for skilled and technically trained engineering customers and users who design with Diodes' products. Diodes' products may be used to facilitate safety-related applications; however, in all instances customers and users are responsible for (a) selecting the appropriate Diodes products for their applications, (b) evaluating the suitability of Diodes' products for their intended applications, (c) ensuring their applications, which incorporate Diodes' products, comply the applicable legal and regulatory requirements as well as safety and functional-safety related standards, and (d) ensuring they design with appropriate safeguards (including testing, validation, quality control techniques, redundancy, malfunction prevention, and appropriate treatment for aging degradation) to minimize the risks associated with their applications.

3. Diodes assumes no liability for any application-related information, support, assistance or feedback that may be provided by Diodes from time to time. Any customer or user of this document or products described herein will assume all risks and liabilities associated with such use, and will hold Diodes and all companies whose products are represented herein or on Diodes' websites, harmless against all damages and liabilities.

4. Products described herein may be covered by one or more United States, international or foreign patents and pending patent applications. Product names and markings noted herein may also be covered by one or more United States, international or foreign trademarks and trademark applications. Diodes does not convey any license under any of its intellectual property rights or the rights of any third parties (including third parties whose products and services may be described in this document or on Diodes' website) under this document.

5. Diodes' products are provided subject to Diodes' Standard Terms and Conditions of Sale (<https://www.diodes.com/about/company/terms-and-conditions/terms-and-conditions-of-sales/>) or other applicable terms. This document does not alter or expand the applicable warranties provided by Diodes. Diodes does not warrant or accept any liability whatsoever in respect of any products purchased through unauthorized sales channel.

6. Diodes' products and technology may not be used for or incorporated into any products or systems whose manufacture, use or sale is prohibited under any applicable laws and regulations. Should customers or users use Diodes' products in contravention of any applicable laws or regulations, or for any unintended or unauthorized application, customers and users will (a) be solely responsible for any damages, losses or penalties arising in connection therewith or as a result thereof, and (b) indemnify and hold Diodes and its representatives and agents harmless against any and all claims, damages, expenses, and attorney fees arising out of, directly or indirectly, any claim relating to any noncompliance with the applicable laws and regulations, as well as any unintended or unauthorized application.

7. While efforts have been made to ensure the information contained in this document is accurate, complete and current, it may contain technical inaccuracies, omissions and typographical errors. Diodes does not warrant that information contained in this document is error-free and Diodes is under no obligation to update or otherwise correct this information. Notwithstanding the foregoing, Diodes reserves the right to make modifications, enhancements, improvements, corrections or other changes without further notice to this document and any product described herein. This document is written in English but may be translated into multiple languages for reference. Only the English version of this document is the final and determinative format released by Diodes.

8. Any unauthorized copying, modification, distribution, transmission, display or other use of this document (or any portion hereof) is prohibited. Diodes assumes no responsibility for any losses incurred by the customers or users or any third parties arising from any such unauthorized use.

9. This Notice may be periodically updated with the most recent version available at <https://www.diodes.com/about/company/terms-and-conditions/important-notice>

The Diodes logo is a registered trademark of Diodes Incorporated in the United States and other countries.

All other trademarks are the property of their respective owners.

© 2023 Diodes Incorporated. All Rights Reserved.

[www.diodes.com](http://www.diodes.com)