Description

The DIODES PI3WVR628 is a two-data-lane MIPI switch. This 6 channel single-pole, double-throw (SPDT) switch is optimized for switching between two high-speed (HS) or low-power (LP) MIPI signal. The PI3WVR628 is designed for the MIPI specification and allows connection to CSI/DSI, C-PHY/D-PHY module.

Application(s)

- Cellular Phones, Smart Phones
- Tablets
- Laptops
- Displays

Features

- 3-lane, 2:1 switches that support D-PHY and C-PHY
- Data rate support: up to 3.5Gbps C-PHY, up to 4.5Gb/s D-PHY.
- Bandwidth: 6.0 GHz Typical
- Low Crosstalk: -30 dB@2.25 GHz
- Input Signals 0 to 1.3V
- R_{ON} : 5.0 Ω Typical LP & HS MIPI
- ΔR_{ON} : 0.1 Ω Typical LP & HS MIPI
- R_{ON_FLAT} : 0.3 Ω Typical LP & HS MIPI
- I_{CCZ} : 1 μ A Maximum
- I_{CC} : 15 μ A Typical
- Skew of Opposite Transitions of the Same Output: 2ps Typical
- V_{DD} Operating Range: 1.5V to 3.6V
- ESD Tolerance: 2kV HBM
- Totally Lead-Free & Fully RoHS Compliant (Notes 1 & 2)
- Halogen and Antimony Free. "Green" Device (Note 3)
- For automotive applications requiring specific change control (i.e. parts qualified to AEC-Q100/101/104/200, PPAP capable, and manufactured in IATF 16949 certified facilities), please [contact us](#) or your local Diodes representative.
<https://www.diodes.com/quality/product-definitions/>
- Packaging (Pb-free & Green):
 - 24-Pin, X1-LGA2417-24 (1.7mm x 2.4mm) (XB)

Notes:

1. No purposely added lead. Fully EU Directive 2002/95/EC (RoHS), 2011/65/EU (RoHS 2) & 2015/863/EU (RoHS 3) compliant.
2. See <https://www.diodes.com/quality/lead-free/> for more information about Diodes Incorporated's definitions of Halogen- and Antimony-free, "Green" and Lead-free.
3. Halogen- and Antimony-free "Green" products are defined as those which contain <900ppm bromine, <900ppm chlorine (<1500ppm total Br + Cl) and <1000ppm antimony compounds.

PI3WVR628

Application Diagram

PI3WVR628 D-PHY

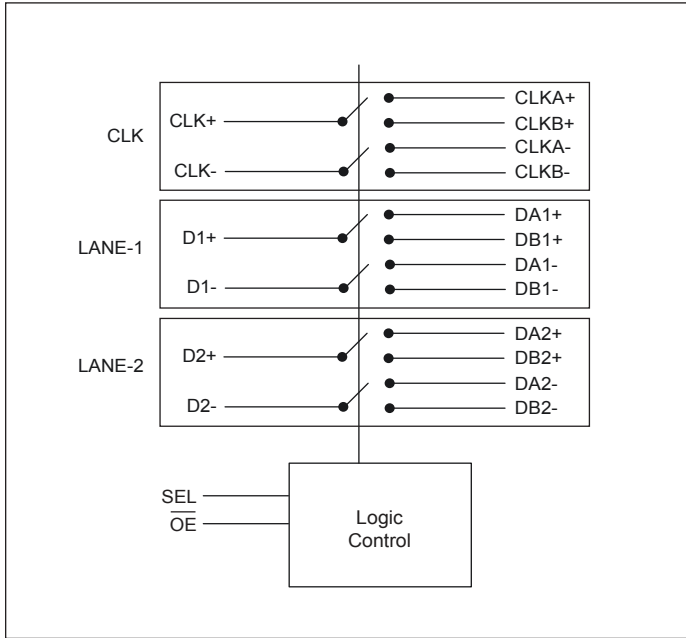

PI3WVR628 C-PHY

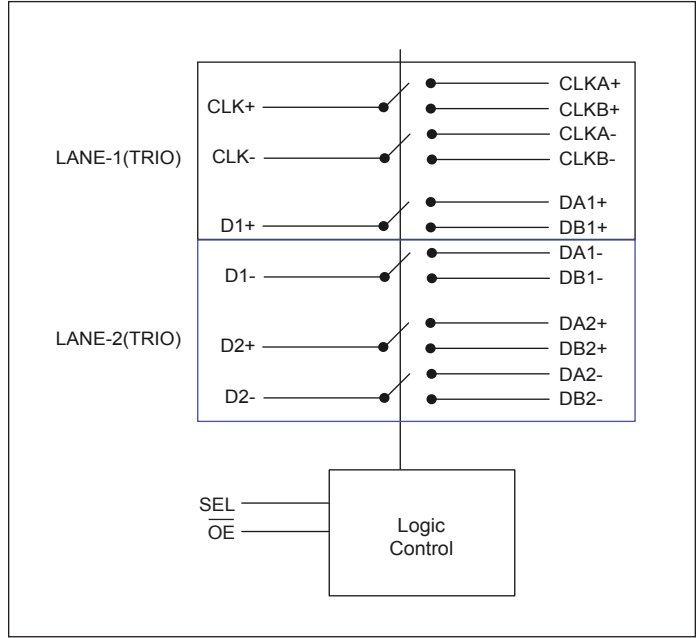

Block Diagram

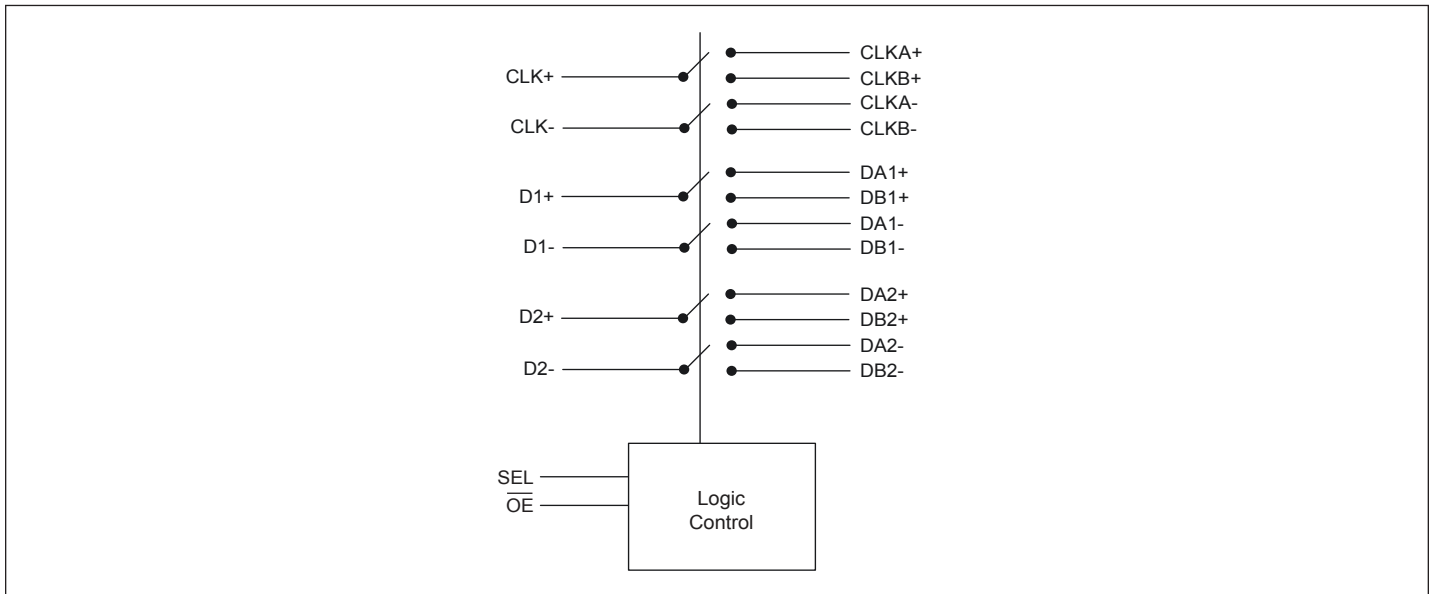

Pin Configuration(Top View)

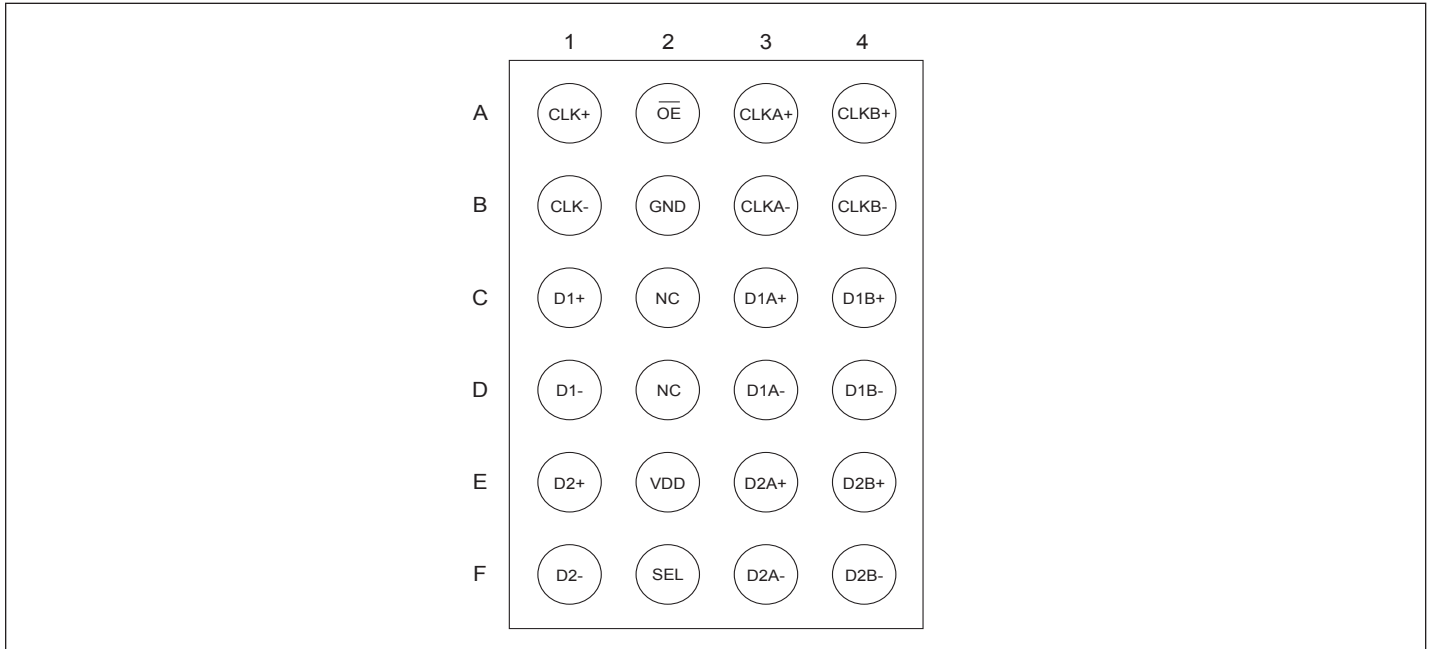

Truth Table

SEL	\overline{OE}	Function
LOW	LOW	CLK+ = CLKA+, CLK- = CLKA-, Dn(+/-) = DAn(+/-)
HIGH	LOW	CLK+ = CLKB+, CLK- = CLKB-, Dn(+/-) = DBn(+/-)
X	HIGH	Clock and Data Ports High Impedance

PI3WVR628

Pin Description

Pin#	Pin Name	Signal Type	Description
E2	V _{DD}	Power	1.5V to 3.3V power supply
B2	GND	Ground	Ground
A2	$\overline{\text{OE}}$	I	Output enable. if OE is low, IC is enabled. if OE is high, IC is power down and all I/Os are Hi-Z
F2	SEL	I	Switch logic control
C2, D2	NC	-	Not Connect
F4	D2B-	I/O	Negative differential signal 2 for port B
E4	D2B+	I/O	Positive differential signal 2 for port B
F3	D2A-	I/O	Negative differential signal 2 for port A
E3	D2A+	I/O	Positive differential signal 2 for port A
F1	D2-	I/O	Negative differential signal 2 for COM port
E1	D2+	I/O	Positive differential signal 2 for COM port
D4	D1B-	I/O	Negative differential signal 1 for port B
C4	D1B+	I/O	Positive differential signal 1 for port B
D3	D1A-	I/O	Negative differential signal 1 for port A
C3	D1A+	I/O	Positive differential signal 1 for port A
D1	D1-	I/O	Negative differential signal 1 for COM port
C1	D1+	I/O	Positive differential signal 1 for COM port
B4	CLKB-	I/O	Clock negative differential signal for port B
A4	CLKB+	I/O	Clock positive differential signal for port B
B3	CLKA-	I/O	Clock negative differential signal for port A
A3	CLKA+	I/O	Clock positive differential signal for port A
B1	CLK-	I/O	Clock negative differential signal for COM port
A1	CLK+	I/O	Clock positive differential signal for COM port

Absolute Maximum Ratings

(Above which useful life may be impaired. For user guidelines, not tested.)

V _{CC} , Supply Voltage,	-0.5V to 4.6V
V _{CNTRL} , DC Input Voltage (\overline{OE} , SEL) ⁽¹⁾	-0.5V to V _{CC}
V _{SW} , DC Switch I/O Voltage ^(1,2)	-0.3V to 2.5V
I _{IK} , DC Input Diodes Current	-50mA
I _{OUT} , DC Output Current	25mA
T _{STG} , Storage Temperature	-65°C to +150°C
T _j , Junction Temperature	125°C
ESD:	
Human Body Model, JEDEC: JESD22-A114, All Pins	2.0kV
Charged Device Model, JEDEC: JESD22-C101.....	1.0kV

Note:

Stresses greater than those listed under MAXIMUM RATINGS may cause permanent damage to the device. This is a stress rating only and functional operation of the device at these or any other conditions above those indicated in the operational sections of this specification is not implied. Exposure to absolute maximum rating conditions for extended periods may affect reliability.

Note:

1. The input and output negative ratings may be exceeded if the input and output diode current ratings are observed.
2. V_{SW} refers to analog data switch paths.

Recommended Operating Conditions

The Recommended operating Conditions table defines the conditions for actual device operation. Recommended operating conditions are specified to ensure optimal performance to the datasheet specifications.

Symbol	Description	Test Conditions	Min.	Max.	Units
V _{CC}	Supply Voltage		1.5	3.6	V
V _{CNTRL}	Control Input Voltage (SEL, \overline{OE}) ⁽¹⁾		0	V _{CC}	V
V _{SW}	Switch I/O Voltage (CLK-, D-, CLKA-, CLKB-, DA-, DB-)	HS Mode	0	0.5	V
		LP Mode	0	1.3	V
T _A	Operating Temperature		-40	+85	°C

Note:

1. The control inputs must be held HIGH or LOW; they must not float.

DC and Transient Characteristics

All typical values are at T_A = 25°C unless otherwise specified.

Symbol	Description	Test Conditions	V _{CC} (V)	T _A = -40°C to +85°C			Units
				Min.	Typ.	Max.	
V _{IK}	Clamp Diode Voltage (\overline{OE} , SEL)	I _{IN} = -18mA	1.5	-1.2		-0.6	V
V _{IH}	Input Voltage High	SEL, \overline{OE}	1.5 to 3.3	1.0			V
V _{IL}	Input Voltage Low	SEL, \overline{OE}	1.5 to 3.3			0.5	V
I _{IN}	Control Input Leakage (\overline{OE} , SEL)	V _{CNTRL} = 0 to V _{CC}	3.3	-0.5		0.5	μA
I _{NO(OFF)} I _{NC(OFF)}	Off Leakage Current of Port CLKA-, DA-, CLKB- and DB-	V _{SW} = 0.0 ≤ DATA ≤ 1.3V	3.3	-0.5		0.5	μA

PI3WVR628

Symbol	Description	Test Conditions	V _{CC} (V)	T _A = -40°C to +85°C			Units
				Min.	Typ.	Max.	
I _{A(ON)}	On Leakage Current of Common Ports (CLK-, D-)	V _{SW} = 0.0 ≤ DATA ≤ 1.3V	3.3	-0.5		0.5	μA
I _{OFF}	Power-Off Leakage Current (All I/O Ports)	V _{SW} = 0.0 or 1.3V	0	-0.5		0.5	μA
I _{OZ}	Off-State Leakage	V _{SW} = 0.0 ≤ DATA ≤ 1.3V, OE = High	3.3	-0.5		0.5	μA
R _{ON_MIPI_HS}	Switch On Resistance for HS MIPI	I _{ON} = -8mA, OE = 0V, SEL = V _{CC} or 0V, CLKA, CLKB, DB- or DA- = 0.2V	1.5		5		Ω
			2.5				
			3.3				
R _{ON_MIPI_LP}	Switch On Resistance for LP MIPI	I _{ON} = -8mA, OE = 0V, SEL = V _{CC} or 0V, CLKA, CLKB, DB- or DA- = 1.2V	1.5		5		Ω
			2.5				
			3.3				
ΔR _{ON_MIPI_HS}	On Resistance Matching Between HS MIPI Channels ⁽¹⁾	I _{ON} = -8mA, OE = 0V, SEL = V _{CC} or 0V, CLKA, CLKB, DB- or DA- = 0.2V	1.5		0.1		Ω
			2.5				
			3.3				
ΔR _{ON_MIPI_LP}	On Resistance Matching Between LP MIPI Channels ⁽¹⁾	I _{ON} = -8mA, OE = 0V, SEL = V _{CC} or 0V, CLKA, CLKB, DB- or DA- = 1.2V	1.5		0.1		Ω
			2.5				
			3.3				
R _{ON_FLAT_MIPI_HS}	On Resistance Flatness for HS MIPI	I _{ON} = -8mA, OE = 0V, SEL = V _{CC} or 0V, CLKA, CLKB, DB- or DA- = 0 to 0.5V	1.5		0.3		Ω
			2.5				
			3.3				
R _{ON_FLAT_MIPI_LP}	On Resistance Flatness for LP MIPI	I _{ON} = -8mA, OE = 0V, SEL = V _{CC} or 0V, CLKA, CLKB, DB- or DA- = 0 to 1.3V	1.5		0.3		Ω
			2.5				
			3.3				
I _{CC}	Quiescent Supply Current	V _{SEL} = 0 or V _{CC} , I _{OUT} = 0, OE = 0V	3.6		11	20	μA
I _{CCZ}	Quiescent Supply Current (High Impedance)	V _{SEL} = 0 or V _{CC} , I _{OUT} = 0, OE = 0V	3.6			1	μA
I _{CCCT}	Increase in I _{CC} Current Per Control Voltage and V _{CC}	V _{SEL} = 0 or V _{CC} , OE = 1.5V	3.6		1		μA

AC Electrical Characteristics

All typical values are for $V_{CC} = 3.3V$ and $T_A = 25^\circ C$ unless otherwise specified.

Symbol	Description	Test Conditions	V_{CC} (V)	$T_A = -40^\circ C$ to $+85^\circ C$			Units
				Min.	Typ.	Max.	
t_{INIT}	Initialization Time V_{CC} to Output ⁽¹⁾	$R_L = 50\Omega, C_L = 0pF, V_{SW} = 0.6V$	1.5 to 3.6		60		μs
t_{EN}	Enable Time \overline{OE} to Output	$R_L = 50\Omega, C_L = 0pF, V_{SW} = 0.6V$	1.5 to 3.6		60	150	μs
t_{DIS}	Disable Time \overline{OE} to Output	$R_L = 50\Omega, C_L = 0pF, V_{SW} = 0.6V$	1.5 to 3.6		35	250	ns
t_{ON}	Turn-On Time SEL to Output	$R_L = 50\Omega, C_L = 0pF, V_{SW} = 0.6V$	1.5 to 3.6		350	1100	ns
t_{OFF}	Turn-Off Time SEL to Output	$R_L = 50\Omega, C_L = 0pF, V_{SW} = 0.6V$	1.5 to 3.6		125	800	ns
t_{BBM}	Break-Before-Make Time	$R_L = 50\Omega, C_L = 0pF, V_{SW} = 0.6V$	1.5 to 3.6			450	ns
t_{PD}	Propagation Delay ⁽¹⁾	$C_L = 0pF, R_L = 50\Omega$	1.5 to 3.6			0.25	ns
O_{IRR}	Differential Off Isolation for MIPI ⁽¹⁾	$R_L = 50\Omega, f = 1250MHz, OE = HIGH, V_{SW} = 0.5V$	1.5 to 3.6		-26		dB
X_{TALK}	Differential Crosstalk for MIPI ⁽¹⁾	$R_L = 50\Omega, f = 1250MHz, SEL = HIGH, V_{SW} = 0.5V$	1.5 to 3.6			-35	dB
		$R_L = 50\Omega, f = 2250MHz, SEL = LOW, V_{SW} = 0.5V$				-30	
I_{LOSS}	Differential Insertion Loss ⁽¹⁾	$R_L = 50\Omega, C_L = 0pF, f = 2250MHz, V_{SW} = 0.5V$	1.5 to 3.6		-1.1		dB
		$R_L = 50\Omega, C_L = 0pF, f = 1250MHz, V_{SW} = 0.5V$	1.5 to 3.6		-0.8		
BW	Differential -3db Bandwidth ⁽¹⁾	$R_L = 50\Omega, C_L = 0pF, V_{SW} = 0.5V$	1.5 to 3.6	5	6		GHz

Note:

1. Guaranteed by characterization.

High-Speed-Related AC Electrical Characteristics

Symbol	Description	Test Conditions	V _{CC} (V)	T _A = -40°C to +85°C			Units
				Min.	Typ.	Max.	
t _{SK(P)}	D-PHY HS Mode Skew of Opposite Transitions of the Same Output ⁽¹⁾	R _L = 50Ω, C _L = 0pF, V _{SW} = 0.3V	1.5 to 3.6		4		ps
	C-PHY HS Mode Skew of 3 channels in same lane	R _L = 50Ω, C _L = 0pF, V _{SW} = 0.5V	1.5 to 3.6		4		
	D-PHY HS Mode Skew of all group A or group B channels ⁽¹⁾	R _L = 50Ω, C _L = 0pF, V _{SW} = 0.3V	1.5 to 3.6		8		

Note:

1. Guaranteed by characterization.

Capacitance

Symbol	Description	Test Conditions	T _A = -40°C to +85°C			Units
			Min.	Typ.	Max.	
C _{IN}	Control Pin Input Capacitance ⁽¹⁾	V _{CC} = 0V, f = 1MHz		2.1		pF
C _{ON}	On Capacitance ⁽¹⁾	V _{CC} = 3.3V, \overline{OE} = 0V, f = 1250MHz (In HS common value)		1.3		pF
C _{OFF}	Off Capacitance ⁽¹⁾	V _{CC} or \overline{OE} = 3.3V, f = 1250MHz (Both sides in HS common value)		0.8		pF

Note:

1. Guaranteed by characterization.

PI3WVR628

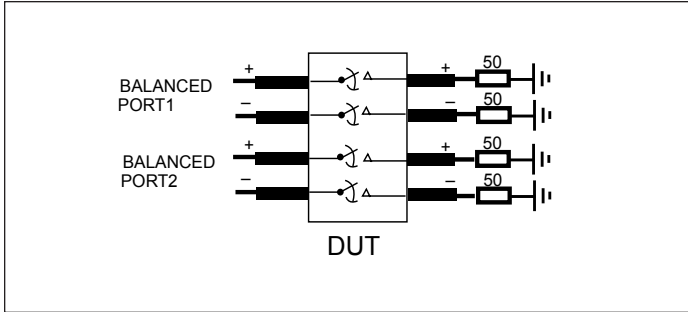

Figure 1. Crosstalk Setup

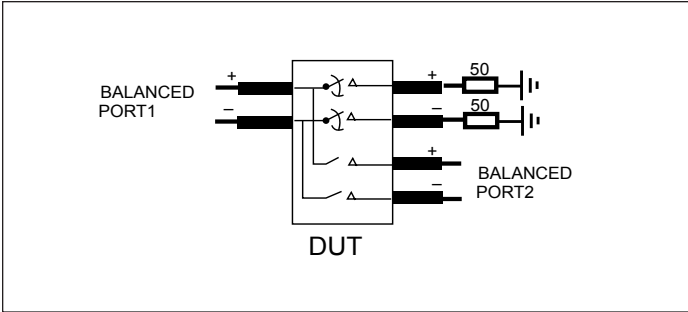

Figure 2. Off-Isolation Setup

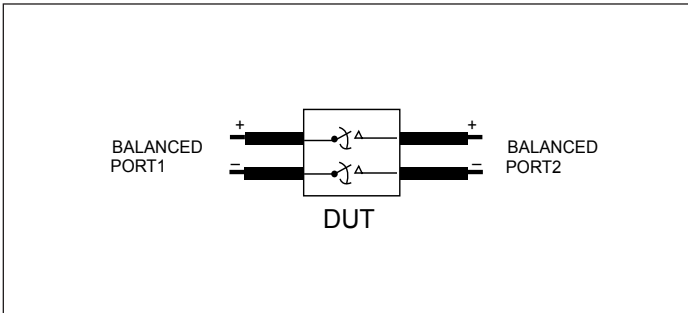
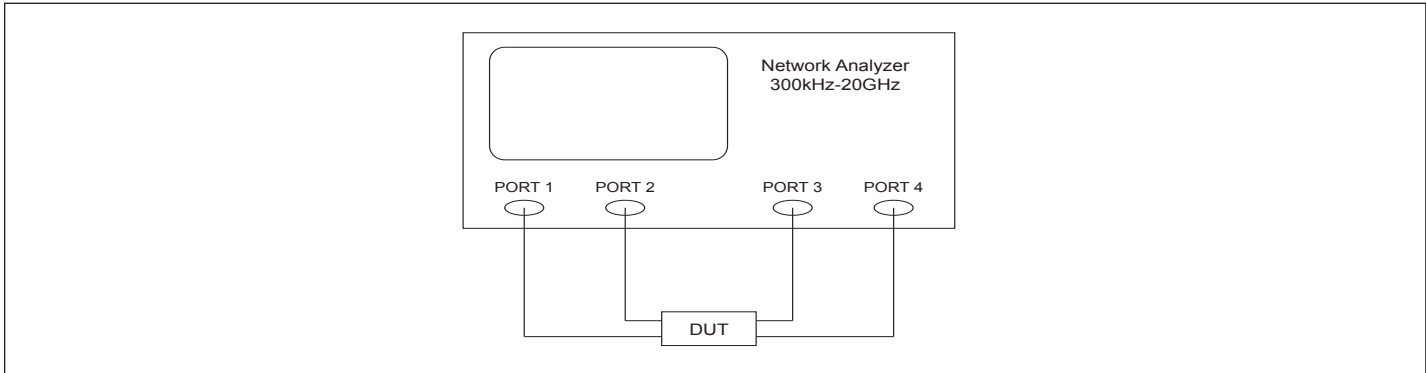
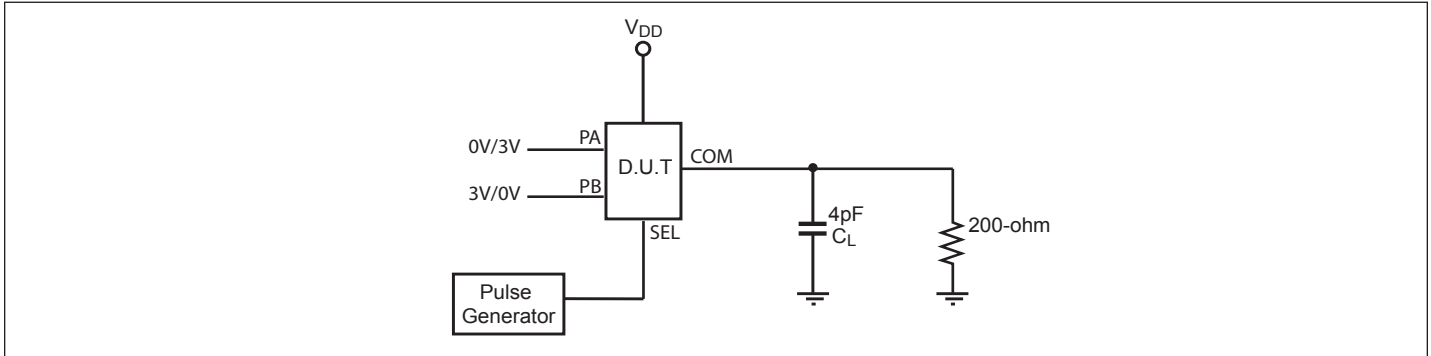

Figure 3. Differential Insertion Loss

Test Circuit for Dynamic Electrical Characteristics



Test Circuit for Electrical Characteristics⁽¹⁻⁴⁾



Notes:

1. C_L = Load capacitance: includes jig and probe capacitance.
2. R_T = Termination resistance: should be equal to Z_{OUT} of the Pulse Generator
3. All input impulses are supplied by generators having the following characteristics: $PRR \leq \text{MHz}$, $Z_O = 50\Omega$, $t_R \leq 2.5\text{ns}$, $t_F \leq 2.5\text{ns}$.
4. The outputs are measured one at a time with one transition per measurement.

Switching Waveforms

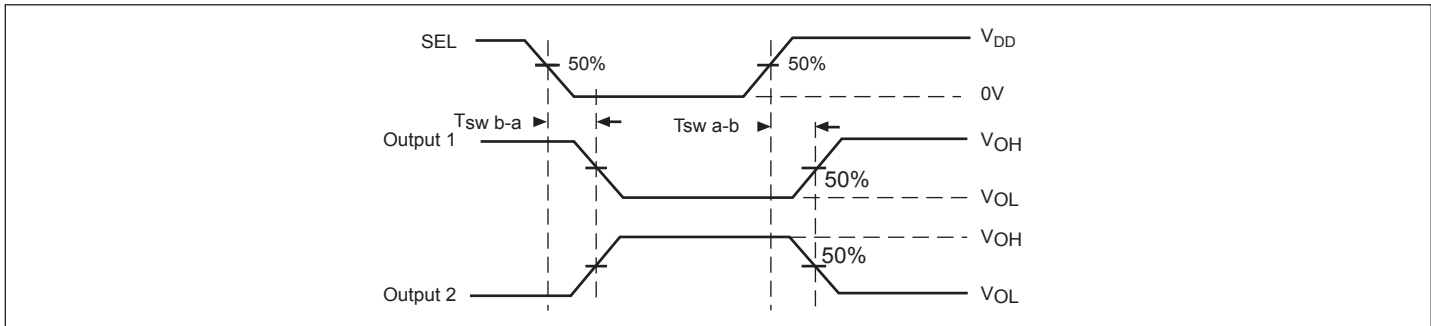

Voltage Waveforms for Select Timing

Test Condition

Output 1 Test Condition	Output 2 Test Condition
PA = Low	PA = High
PB = High	PB = Low

Part Marking

628XB
YWXX

○

Y: Shortened Date Code (Year)
W: Shortened Date Code (Workweek)
1st X: Assembly Code
2nd X: Fab Code

Packaging Mechanical

24-X1-LGA2417-24 (XB)

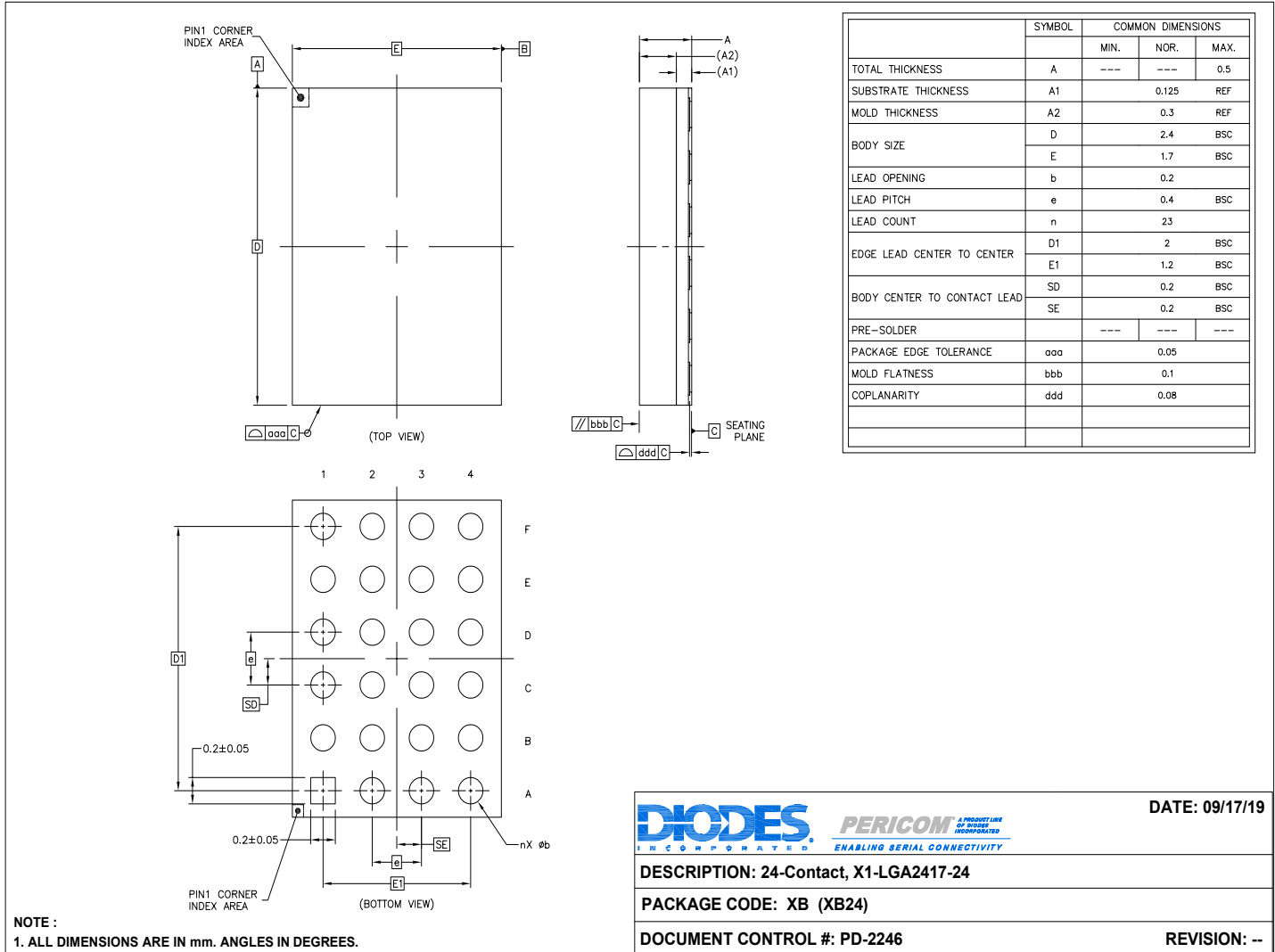

DIODES **PERICOM** A PRODUCT LINE OF DIODES INCORPORATED ENABLING SERIAL CONNECTIVITY

DATE: 09/17/19

DESCRIPTION: 24-Contact, X1-LGA2417-24

PACKAGE CODE: XB (XB24)

DOCUMENT CONTROL #: PD-2246 **REVISION: --**

For latest package info.

please check: <http://www.diodes.com/design/support/packaging/pericom-packaging/packaging-mechanicals-and-thermal-characteristics/>

Ordering Information

Ordering Code	Package Code	Package Description
PI3WVR628XBEX	XB	24-contact, X1-LGA2417-24

Notes:

1. No purposely added lead. Fully EU Directive 2002/95/EC (RoHS), 2011/65/EU (RoHS 2) & 2015/863/EU (RoHS 3) compliant.
2. See <https://www.diodes.com/quality/lead-free/> for more information about Diodes Incorporated's definitions of Halogen- and Antimony-free, "Green" and Lead-free.
3. Halogen- and Antimony-free "Green" products are defined as those which contain <900ppm bromine, <900ppm chlorine (<1500ppm total Br + Cl) and <1000ppm antimony compounds.
4. E = Pb-free and Green
5. X suffix = Tape/Reel

IMPORTANT NOTICE

1. DIODES INCORPORATED (Diodes) AND ITS SUBSIDIARIES MAKE NO WARRANTY OF ANY KIND, EXPRESS OR IMPLIED, WITH REGARDS TO ANY INFORMATION CONTAINED IN THIS DOCUMENT, INCLUDING, BUT NOT LIMITED TO, THE IMPLIED WARRANTIES OF MERCHANTABILITY, FITNESS FOR A PARTICULAR PURPOSE OR NON-INFRINGEMENT OF THIRD PARTY INTELLECTUAL PROPERTY RIGHTS (AND THEIR EQUIVALENTS UNDER THE LAWS OF ANY JURISDICTION).

2. The Information contained herein is for informational purpose only and is provided only to illustrate the operation of Diodes' products described herein and application examples. Diodes does not assume any liability arising out of the application or use of this document or any product described herein. This document is intended for skilled and technically trained engineering customers and users who design with Diodes' products. Diodes' products may be used to facilitate safety-related applications; however, in all instances customers and users are responsible for (a) selecting the appropriate Diodes products for their applications, (b) evaluating the suitability of Diodes' products for their intended applications, (c) ensuring their applications, which incorporate Diodes' products, comply the applicable legal and regulatory requirements as well as safety and functional-safety related standards, and (d) ensuring they design with appropriate safeguards (including testing, validation, quality control techniques, redundancy, malfunction prevention, and appropriate treatment for aging degradation) to minimize the risks associated with their applications.

3. Diodes assumes no liability for any application-related information, support, assistance or feedback that may be provided by Diodes from time to time. Any customer or user of this document or products described herein will assume all risks and liabilities associated with such use, and will hold Diodes and all companies whose products are represented herein or on Diodes' websites, harmless against all damages and liabilities.

4. Products described herein may be covered by one or more United States, international or foreign patents and pending patent applications. Product names and markings noted herein may also be covered by one or more United States, international or foreign trademarks and trademark applications. Diodes does not convey any license under any of its intellectual property rights or the rights of any third parties (including third parties whose products and services may be described in this document or on Diodes' website) under this document.

5. Diodes' products are provided subject to Diodes' Standard Terms and Conditions of Sale (<https://www.diodes.com/about/company/terms-and-conditions/terms-and-conditions-of-sales/>) or other applicable terms. This document does not alter or expand the applicable warranties provided by Diodes. Diodes does not warrant or accept any liability whatsoever in respect of any products purchased through unauthorized sales channel.

6. Diodes' products and technology may not be used for or incorporated into any products or systems whose manufacture, use or sale is prohibited under any applicable laws and regulations. Should customers or users use Diodes' products in contravention of any applicable laws or regulations, or for any unintended or unauthorized application, customers and users will (a) be solely responsible for any damages, losses or penalties arising in connection therewith or as a result thereof, and (b) indemnify and hold Diodes and its representatives and agents harmless against any and all claims, damages, expenses, and attorney fees arising out of, directly or indirectly, any claim relating to any noncompliance with the applicable laws and regulations, as well as any unintended or unauthorized application.

7. While efforts have been made to ensure the information contained in this document is accurate, complete and current, it may contain technical inaccuracies, omissions and typographical errors. Diodes does not warrant that information contained in this document is error-free and Diodes is under no obligation to update or otherwise correct this information. Notwithstanding the foregoing, Diodes reserves the right to make modifications, enhancements, improvements, corrections or other changes without further notice to this document and any product described herein. This document is written in English but may be translated into multiple languages for reference. Only the English version of this document is the final and determinative format released by Diodes.

8. Any unauthorized copying, modification, distribution, transmission, display or other use of this document (or any portion hereof) is prohibited. Diodes assumes no responsibility for any losses incurred by the customers or users or any third parties arising from any such unauthorized use.

9. This Notice may be periodically updated with the most recent version available at <https://www.diodes.com/about/company/terms-and-conditions/important-notice>

The Diodes logo is a registered trademark of Diodes Incorporated in the United States and other countries.

All other trademarks are the property of their respective owners.

© 2024 Diodes Incorporated. All Rights Reserved.

www.diodes.com