

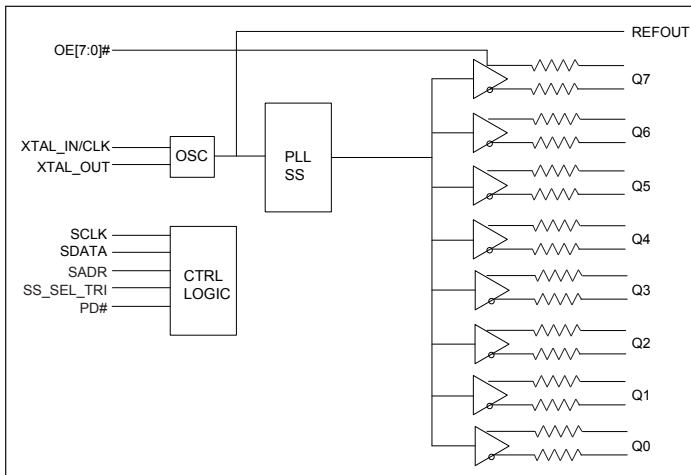
### 3.3V Very Low Power 8-Output PCIe Clock Generator With On-Chip Termination

#### Description

The DIODES PI6CG33802C is an 8-output, very-low-power PCIe Gen1/Gen2/Gen3/Gen4/Gen5/Gen6 clock generator. It uses a 25MHz crystal or CMOS reference as an input to generate the 100MHz low-power differential HCSL outputs with on-chip terminations. The on-chip termination can save 32 external resistors and make layout easier. An additional buffered reference output is provided to serve as a low-noise reference for other circuitry.

It uses Diodes' proprietary PLL design to achieve very-low jitter that meets PCIe Gen1/Gen2/Gen3/Gen4/Gen5/Gen6 requirements. It also provides various options, such as different slew rate and amplitude through SMBUS, so users can easily configure the device to get the optimized performance for their individual boards. The device also supports selectable spread-spectrum options to reduce EMI for various applications.

#### Block Diagram



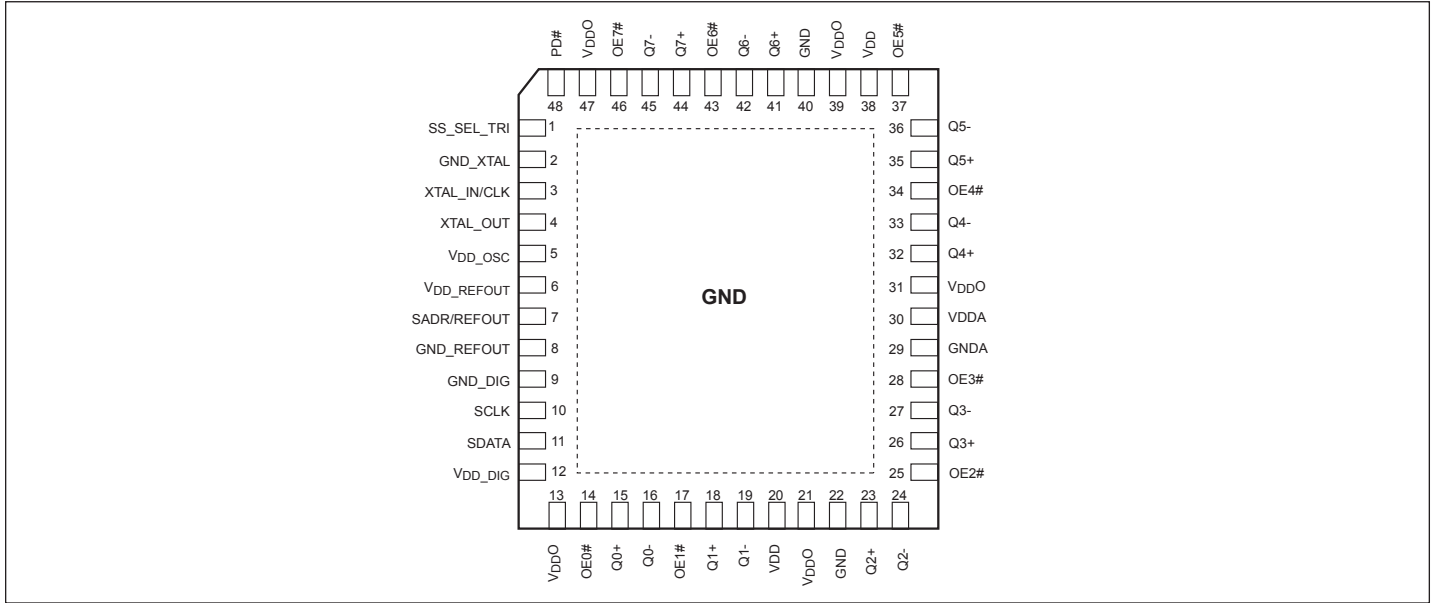
#### Features

- 3.3V Supply Voltage
- Crystal/CMOS Input: 25 MHz
- Eight Differential Low-Power HCSL Outputs with On-Chip Termination
- Default  $Z_{OUT} = 85\Omega$
- Individual Output Enable
- Reference CMOS Output
- Programmable Slew Rate and Output Amplitude for Each Output
- Differential Outputs Blocked Until PLL is Locked
- Selectable 0%, -0.25%, or -0.5% Spread on Differential Outputs
- Strapping Pins or SMBus for Configuration
- Differential Output-To-Output Skew <60ps
- Very-Low Jitter Outputs
  - Differential Cycle-To-Cycle Jitter <50ps
  - PCIe Gen1/Gen2/Gen3/Gen4/Gen5/Gen6 Compliant
  - CMOS REFOUT Phase Jitter
    - <0.3ps RMS, SSC off
    - <1.5ps RMS, SSC on
- Totally Lead-Free & Fully RoHS Compliant (Notes 1 & 2)
- Halogen and Antimony Free. “Green” Device (Note 3)
- For automotive applications requiring specific change control (i.e. parts qualified to AEC-Q100/101/104/200, PPAP capable, and manufactured in IATF 16949 certified facilities), please [contact us](mailto:contact@diodes.com) or your local Diodes representative. <https://www.diodes.com/quality/product-definitions/>
- Packaging (Pb-free & Green):
  - 48-lead 6mm × 6mm TQFN

#### Notes:

1. No purposely added lead. Fully EU Directive 2002/95/EC (RoHS), 2011/65/EU (RoHS 2) & 2015/863/EU (RoHS 3) compliant.
2. See <https://www.diodes.com/quality/lead-free/> for more information about Diodes Incorporated’s definitions of Halogen- and Antimony-free, “Green” and Lead-free.
3. Halogen- and Antimony-free “Green” products are defined as those which contain <900ppm bromine, <900ppm chlorine (<1500ppm total Br + Cl) and <1000ppm antimony compounds.

## Pin Configuration



## Pin Description

Pin #	Pin Name	Type	Description
1	SS_SEL_TRI	Input	Tri-level Latched select input to select spread spectrum amount at initial power up. 1 = -0.5% spread, M = Spread Off, 0 = Spread Off. This pin has both internal pull-up and pull-down. Refer to SMBUS byte_1 bit 4, 3 = '01' to get -0.25% spread.
2	GND_XTAL	Power	Ground for oscillator circuit
3	XTAL_IN/CLK	Input	Crystal input or CMOS reference input
4	XTAL_OUT	Output	Crystal output
5	VDD_OSC	Power	Power supply for oscillator circuitry, nominal 3.3V
6	VDD_REFOUT	Power	Power supply for buffered CMOS output
7	SADR/REFOUT	Input/Output	CMOS Latch to select SMBus Address or LVCMOS REFOUT. This pin has an internal pull-down
8	GND_REFOUT	Power	Ground for REFOUT
9	GND_DIG	Power	Ground for digital circuitry
10	SCLK	Input	CMOS SMBUS clock input, 3.3V tolerant
11	SDATA	Input/Output	CMOS SMBUS data line, 3.3V tolerant
12	VDD_DIG	Power	Power supply for digital circuitry, nominal 3.3V
13, 21, 31, 39, 47	VDDO	Power	Power supply for differential outputs
14	OE0#	Input	CMOS Active-low input for enabling Q0 pair. This pin has an internal pulldown. 1 = disable outputs, 0 = enable outputs

Pin #	Pin Name	Type		Description
15	Q0+	Output	HCSL	Differential true clock output
16	Q0-	Output	HCSL	Differential complementary clock output
17	OE1#	Input	CMOS	Active low input for enabling Q1 pair. This pin has an internal pulldown. 1 = disable outputs, 0 = enable outputs
18	Q1+	Output	HCSL	Differential true clock output
19	Q1-	Output	HCSL	Differential complementary clock output
20, 38	V <sub>DD</sub>	Power		Power supply, nominal 3.3V
22, 40	GND	Power		Ground
23	Q2+	Output	HCSL	Differential true clock output
24	Q2-	Output	HCSL	Differential complementary clock output
25	OE2#	Input	CMOS	Active low input for enabling Q2 pair. This pin has an internal pulldown. 1 = disable outputs, 0 = enable outputs
26	Q3+	Output	HCSL	Differential true clock output
27	Q3-	Output	HCSL	Differential complementary clock output
28	OE3#	Input	CMOS	Active low input for enabling Q3 pair. This pin has an internal pulldown. 1 = disable outputs, 0 = enable outputs
29	GNDA	Power		Ground for analog circuitry
30	V <sub>DDA</sub>	Power		Power supply for analog circuitry
32	Q4+	Output	HCSL	Differential true clock output
33	Q4-	Output	HCSL	Differential complementary clock output
34	OE4#	Input	CMOS	Active low input for enabling Q4 pair. This pin has an internal pulldown. 1 = disable outputs, 0 = enable outputs
35	Q5+	Output	HCSL	Differential true clock output
36	Q5-	Output	HCSL	Differential complementary clock output
37	OE5#	Input	CMOS	Active low input for enabling Q5 pair. This pin has an internal pulldown. 1 = disable outputs, 0 = enable outputs
41	Q6+	Output	HCSL	Differential true clock output
42	Q6-	Output	HCSL	Differential complementary clock output
43	OE6#	Input	CMOS	Active low input for enabling Q6 pair. This pin has an internal pulldown. 1 = disable outputs, 0 = enable outputs
44	Q7+	Output	HCSL	Differential true clock output
45	Q7-	Output	HCSL	Differential complementary clock output
46	OE7#	Input	CMOS	Active low input for enabling Q7 pair. This pin has an internal pulldown. 1 = disable outputs, 0 = enable outputs
48	PD#	Input	CMOS	Input notifies device to sample latched inputs and start up on first high assertion. Low enters Power Down Mode, subsequent high assertions exit Power Down Mode. This pin has internal pull-up resistor.

**Table 1. SMBus Address Selection Table**

	SADR	Address	+Read/Write Bit
State of SADR on first application of PD#	0	1101000	X
	1	1101010	X

**Table 2. Power Management Table<sup>(3)</sup>**

PD#	SMBus OE bit	OEn#	Qn+	Qn-	REFOUT
0	X	X	Low <sup>(1)</sup>	Low <sup>(1)</sup>	HiZ <sup>(2)</sup>
1	1	0	Running	Running	Running
1	1	1	Disabled <sup>(1)</sup>	Disabled <sup>(1)</sup>	Running
1	0	X	Disabled <sup>(1)</sup>	Disabled <sup>(1)</sup>	Disabled <sup>(4)</sup>

**Notes:**

1. The output state is set by B11[1:0] (Low/Low default).
2. REF is Hi-Z until the first assertion of PD# high. After this, when PD# is low, REF is disabled. If Byte3, bit 5 = 1, REF is running.
3. Input High/ Low defined at default values for device.
4. See SMBUs Byte 3, bit 4.

## Maximum Ratings

(Above which useful life may be impaired. For user guidelines, not tested.)

Storage Temperature.....	-65°C to +150°C
Supply Voltage to Ground Potential, $V_{DDXX}$ .....	-0.5V to +4.6V
Input Voltage .....	-0.5V to $V_{DD}+0.5V$ , not exceed 4.6V
SMBus, Input High Voltage .....	3.6V
ESD Protection (HBM) .....	2000V
Max Junction Temperature .....	+125°C

### Note:

Stresses greater than those listed under MAXIMUM RATINGS may cause permanent damage to the device. This is a stress rating only and functional operation of the device at these or any other conditions above those indicated in the operational sections of this specification is not implied. Exposure to absolute maximum rating conditions for extended periods may affect reliability.

## Operating Conditions

Temperature =  $T_A$ ; Supply voltages per normal operation conditions; See test circuits for the load conditions

Symbol	Parameters	Conditions	Min.	Typ.	Max.	Units
$V_{DD}, V_{DDA}, V_{DD\_OSC}, V_{DD\_DIG},$	Power Supply Voltage		3.135	3.3	3.465	V
$V_{DDO}$	Output Power Supply Voltage		1.0	3.3	3.465	V
$V_{DD\_REFOUT}$	Reference Output Power Supply Voltage		3.135	3.3	3.465	V
$I_{DDA}$	Analog Power Supply Current	All outputs active @100MHz		22	25	mA
$I_{DD}$	Power Supply Current	All $V_{DD}$ , except $V_{DDA}$ and $V_{DDO}$ , All outputs active @100MHz		20	25	mA
$I_{DDO}$	Power Supply Current for Outputs <sup>(3)</sup>	All outputs active @100MHz		29	34	mA
$I_{DDA\_WL}$	Analog Power Supply Wake-on-LAN <sup>(1)</sup> Current	Q outputs off, REF output running		0.5	1	mA
$I_{DD\_WL}$	Power Supply Wake-on-LAN <sup>(1)</sup> Current	All $V_{DD}$ , except $V_{DDA}$ and $V_{DDO}$ , Q outputs off, REF output running		3	6	mA
$I_{DDO\_WL}$	Power Supply Wake-on-LAN <sup>(1)</sup> Current for Outputs	Q outputs off, REF output running		0.04	0.1	mA
$I_{DDA\_PD}$	Analog Power Supply Power Down <sup>(2)</sup> Current	All outputs off		0.5	1	mA
$I_{DD\_PD}$	Power Supply Power Down <sup>(2)</sup> Current	All outputs off		1	2	mA
$I_{DDO\_PD}$	Power Supply Current Power Down <sup>(2)</sup> for Outputs	All outputs off		0.05	0.1	mA
$T_A$	Ambient Temperature	Industrial grade	-40		85	°C

### Notes:

1. Wake-on-LAN mode: PD# = '0' Byte 3, bit 5 = '1'.
2. Power down mode: PD# = '0' Byte 3, bit 5 = '0'.
3. Output drive 5 inch trace.

## Input Electrical Characteristics

Symbol	Parameters	Conditions	Min.	Typ.	Max.	Units
R <sub>pu</sub>	Internal Pullup Resistance			120		KΩ
R <sub>dn</sub>	Internal Pulldown Resistance			120		KΩ
C <sub>XTAL</sub>	Internal Capacitance on X_IN and X_OUT pins			8		pF
L <sub>PIN</sub>	Pin Inductance				7	nH

## Crystal Characteristic

Parameters	Description	Min.	Typ	Max.	Units
OSCmode	Mode of Oscillation	Fundamental			
FREQ	Frequency		25		MHz
ESR <sup>(1)</sup>	Equivalent Series Resistance			50	Ω
Cload	Load Capacitance		8		pF
Cshunt	Shunt Capacitance			7	pF
	Drive Level			200	uW

**Note:**

- ESR value is dependent upon frequency of oscillation.

## SMBus Electrical Characteristics

Temperature = T<sub>A</sub>; Supply voltages per normal operation conditions; See test circuits for the load conditions

Symbol	Parameters	Conditions	Min.	Typ.	Max.	Units
V <sub>DDSMB</sub>	Nominal bus voltage		2.7		3.6	V
V <sub>IHSMB</sub>	SMBus Input High Voltage	SMBus, V <sub>DDSMB</sub> = 3.3V	2.1		3.6	V
		SMBus, V <sub>DDSMB</sub> < 3.3V	0.65 V <sub>DDSMB</sub>			
V <sub>ILSMB</sub>	SMBus Input Low Voltage	SMBus, V <sub>DDSMB</sub> = 3.3V			0.8	V
		SMBus, V <sub>DDSMB</sub> < 3.3V			0.8	
I <sub>SMBSINK</sub>	SMBus Sink Current	SMBus, at V <sub>OLSMB</sub>	4			mA
V <sub>OLSMB</sub>	SMBus Output Low Voltage	SMBus, at I <sub>SMBSINK</sub>			0.4	V
f <sub>MAXSMB</sub>	SMBus Operating Frequency	Maximum frequency			500	kHz
t <sub>RMSB</sub>	SMBus Rise Time	(Max V <sub>IL</sub> - 0.15) to (Min V <sub>IH</sub> + 0.15)			1000	ns
t <sub>FMSB</sub>	SMBus Fall Time	(Min V <sub>IH</sub> + 0.15) to (Max V <sub>IL</sub> - 0.15)			300	ns

## Spread Spectrum Characteristic

Temperature =  $T_A$ ; Supply voltages per normal operation conditions; See test circuits for the load conditions

Symbol	Parameters	Conditions	Min.	Typ.	Max.	Units
$f_{MOD}$	SS Modulation Frequency	Triangular modulation	30	31.8	33	kHz

## LVC MOS DC Electrical Characteristics

Temperature =  $T_A$ ; Supply voltages per normal operation conditions; See test circuits for the load conditions

Symbol	Parameters	Conditions	Min.	Typ.	Max.	Units
$V_{IH}$	Input High Voltage	Single-ended inputs, except SMBus	0.75 $V_{DD}$		$V_{DD} + 0.3$	V
$V_{IM}$	Input Mid Voltage	SS_SEL_TRI	0.4 $V_{DD}$	0.5 $V_{DD}$	0.6 $V_{DD}$	V
$V_{IL}$	Input Low Voltage	Single-ended inputs, except SMBus	-0.3		0.25 $V_{DD}$	V
$I_{IH}$	Input High Current	Single-ended inputs, $V_{IN} = V_{DD}$			5	$\mu A$
$I_{IL}$	Input Low Current	Single-ended inputs, $V_{IN} = 0V$	-5			$\mu A$
$I_{IH}$	Input High Current	Single-ended inputs with pullup/ pulldown resistor, $V_{IN} = V_{DD}$			50	$\mu A$
$I_{IL}$	Input Low Current	Single-ended inputs with pullup/ pulldown resistor, $V_{IN} = 0V$	-50			$\mu A$
$V_{OH}$	Output High Voltage	REFOUT, except SMBus; $I_{OH} = -2mA$	0.8 $\times$ $V_{DD\_}$ REFOUT			V
$V_{OL}$	Output Low Voltage	REFOUT, except SMBus; $I_{OL} = 2mA$			0.2 $\times$ $V_{DD\_}$ REFOUT	V
$R_{OUT}$	CMOS Output impedance			20		$\Omega$
$C_{IN}$	Input Capacitance		1.5		5	pF

## LVC MOS AC Characteristics

Temperature =  $T_A$ ; Supply voltages per normal operation conditions; See test circuits for the load conditions.

Symbol	Parameters	Conditions	Min.	Typ.	Max.	Units
$f_{INPUT}$	Input Frequency	XTAL_IN/CLK		25		MHz
$t_{RIN}$	Input Rise Time	Single-ended inputs			5	ns
$t_{FIN}$	Input fall time	Single-ended inputs			5	ns
$t_{STAB}$	Clock Stabilization	From power up and after input clock stabilization or deassertion of PD# to first clock		0.75	1	ms
$t_{OELAT}$	Output Enable Latency	Q start after OE# assertion Q stop after OE# deassertion	1		3	clocks

**PI6CG33802C**

Symbol	Parameters	Conditions	Min.	Typ.	Max.	Units
t <sub>PDLAT</sub>	PD# Deassertion	Differential outputs enable after PD# deassertion		20	300	μs
t <sub>PERIOD</sub>	REFOUT Clock Period	REFOUT, assume input is at 25MHz		40		ns
f <sub>ACC</sub>	REFOUT Frequency Accuracy <sup>(1)</sup>	REFOUT, long term accuracy to input		0		ppm
t <sub>SLEW</sub>	REFOUT Slew Rate <sup>(1)</sup>	Byte 3 = 1F, 20% to 80% of V <sub>D-DREF</sub>	0.9	1.4	2	V/ns
		Byte 3 = 5F, 20% to 80% of V <sub>D-DREF</sub>	1.5	2.4	3.2	V/ns
		Byte 3 = 9F, 20% to 80% of V <sub>D-DREF</sub>	2.0	3.0	3.8	V/ns
		Byte 3 = DF, 20% to 80% of V <sub>D-DREF</sub>	2.3	3.2	4	V/ns
t <sub>DC</sub>	REFOUT Duty Cycle <sup>(1)</sup>	V <sub>T</sub> = V <sub>DD</sub> /2V, driven by a Xtal	45	50	55	%
t <sub>DCDIS</sub>	REFOUT Duty Cycle Distortion	V <sub>T</sub> = V <sub>DD</sub> /2V, driven by an external source	-2	0	+2	%
t <sub>JITCC</sub>	REFOUT Cycle-Cycle Jitter	V <sub>T</sub> = V <sub>DD</sub> /2V, driven by a Xtal		70	150	ps
t <sub>JITPH</sub>	REFOUT Phase Jitter, RMS	12kHz to 5MHz, SSC off, driven by a Xtal		0.16	0.3	ps
		12kHz to 5MHz, SSC on, driven by a Xtal		0.9	1.5	ps
t <sub>JITN</sub>	Noise Floor	1kHz offset, driven by a Xtal		-149	-135	dBc/Hz
		10kHz offset to Nyquist, driven by a Xtal		-158	-140	dBc/Hz

**Note:**

1. Guaranteed by design and characterization—not 100% tested in production.



## HCSL Output Characteristics

Temperature =  $T_A$ ; Supply voltages per normal operation conditions; See test circuits for the load conditions.

Symbol	Parameters	Condition	Min.	Typ.	Max.	Units
$V_{OH}$	Output Voltage High <sup>(1)</sup>	Statistical measurement on single-ended signal using oscilloscope math function	660	784	850	mV
$V_{OL}$	Output Voltage Low <sup>(1)</sup>		-150		150	mV
$V_{OMAX}$	Output Voltage Maximum <sup>(1)</sup>	Measurement on single-ended signal using absolute value		816	1150	mV
$V_{OMIN}$	Output Voltage Minimum <sup>(1)</sup>		-300	-42		mV
$V_{OC}$	Output Cross Voltage <sup>(1,2,4)</sup>		250	430	550	mV
$DV_{OC}$	$V_{OC}$ Magnitude Change <sup>(1,2,5)</sup>			12	140	mV

**Note:**

- At default SMBUS amplitude settings.
- Guaranteed by design and characterization—not 100% tested in production.
- Measured from differential waveform.
- This one is defined as voltage where  $Q+ = Q-$  measured on a component test board and only applied to the differential rising edge.
- The total variation of all  $V_{cross}$  measurements in any particular system. This is a subset of  $V_{cross\_min/max}$  allowed.

## HCSL Output AC Characteristics

Temperature =  $T_A$ ; Supply voltages per normal operation conditions; See test circuits for the load conditions

Symbol	Parameters	Condition	Min.	Typ.	Max.	Units
$f_{OUT}$	Output Frequency			100		MHz
$t_{RF}$	Slew Rate <sup>(1,2,3)</sup>	Scope averaging on fast setting	2.5	3.2	4	V/ns
		Scope averaging on slow setting	2.2	3	3.7	V/ns
$D_{tRF}$	Slew Rate Matching <sup>(1,2,4)</sup>	Scope averaging on		7	15	%
$t_{DC}$	Duty Cycle <sup>(1,2)</sup>	Measured differentially, PLL Mode	45	50	55	%
$t_{SKEW}$	Output Skew <sup>(1,2)</sup>	Averaging on, $V_T = 50\%$		20	60	ps
$t_{jC-C}$	Cycle-to-Cycle Jitter <sup>(1,2)</sup>			20	50	ps

**Note:**

- Guaranteed by design and characterization—not 100% tested in production.
- Measured from differential waveform.
- Slew rate is measured through the  $V_{swing}$  voltage range centered around differential 0V, within  $\pm 150mV$  window.
- It is measured using a  $\pm 75mV$  window centered on the average cross point.

### PCIe Common Clock (CC) Architecture Jitter

Symbol	Parameters	Condition	Min.	Typ.	Max.	Spec Limit	Units
t <sub>JPHASE</sub>	Integrated phase jitter (RMS)	PCIe 1.0		20	30	86	ps (pkpk)
		PCIe 2.0 Low Band, 10kHz < f < 1.5MHz (PLL BW 5-16MHz or 8-5MHz, CDR = 10MHz)		0.1	0.2	3	ps
		PCIe 2.0 High Band, 1.5MHz < f < Nyquist (50MHz); (PLL BW 5-16MHz or 8-5MHz, CDR = 10MHz)		0.4	0.5	3.1	ps
		PCIe 3.0 (PLL BW 2-4MHz or 2-5MHz, CDR = 10MHz)		0.15	0.2	1	ps
		PCIe 4.0 (PLL BW 2-4MHz or 2-5MHz, CDR = 10MHz)		0.15	0.2	0.5	ps
		PCIe 5.0		0.05	0.06	0.15	ps
		PCIe 6.0		0.03	0.04	0.1	ps

### PCIe Independent Reference Clock Architecture Jitter

Symbol	Parameters	Condition	Min.	Typ.	Max.	Spec Limit	Units
t <sub>JPHASE</sub>	Integrated phase jitter (RMS)	PCIe 3.0 SRIS (PLL BW 2-4MHz or 2-5MHz, CDR = 10MHz)		0.15	0.25		ps
		PCIe 4.0 SRIS (PLL BW 2-4MHz or 2-5MHz, CDR = 10MHz)		0.15	0.25		ps
		PCIe 5.0 SRIS		0.04	0.07		ps
		PCIe 6.0 SRIS		0.03	0.05		ps

**Differential Output Clock Periods - Spread Spectrum Disabled**

Center Freq. MHz	Measurement Window							Units
	1 clock	1 $\mu$ s	0.1s	0.1s	0.1s	1 $\mu$ s	1 clock	
	-c2c jitter AbsPer Min	-SSC Short-term Avg. Min	-ppm Long-term Avg. Min	0 ppm Period Nominal	+ppm Long-term Avg. Max	+SSC Short-term Avg. Max	-c2c jitter AbsPer Max	
100.00	9.94900		9.99900	10.00000	10.00100		10.05100	ns

**Differential Output Clock Periods - Spread Spectrum Enabled**

Center Freq. MHz	Measurement Window							Units
	1 clock	1 $\mu$ s	0.1s	0.1s	0.1s	1 $\mu$ s	1 clock	
	-c2c jitter AbsPer Min	-SSC Short-term Avg. Min	-ppm Long-term Avg. Min	0 ppm Period Nominal	+ppm Long-term Avg. Max	+SSC Short-term Avg. Max	-c2c jitter AbsPer Max	
99.75	9.94906	9.99906	10.02406	10.02506	10.02607	10.05107	10.10107	ns

Note:

1. Guaranteed by design and characterization—not 100% tested in production
2. All long-term accuracy and clock period specifications are guaranteed assuming REF is trimmed to 25.00MHz.

## SMBus Serial Data Interface

PI6CG33802C is a slave only device that supports block read and block write protocol using a single 7-bit address and read/write bit as shown below.

Read and write block transfers can be stopped after any complete byte transfer.

### Address Assignment

A6	A5	A4	A3	A2	A1	A0	R/W
1	1	0	1	0	SADR	0	1/0

Note:

- SMBus address is latched on SADR pin.

### How to Write

1 bit	7 bits	1 bit	1 bit	8 bits	1 bit	8 bits	1 bit	8 bits	1 bit		8 bits	1 bit	1 bit
Start bit	Add.	W(0)	Ack	Beginning Byte location = N	Ack	Data Byte count = X	Ack	Beginning Data Byte (N)	Ack	.....	Data Byte (N+X-1)	Ack	Stop bit

### How to Read

1 bit	7 bits	1 bit	1 bit	8 bits	1 bit	1 bit	7 bits	1 bit	1 bit	8 bits	1 bit	8 bits	1 bit
Start bit	Address	W(0)	Ack	Beginning Byte location = N	Ack	Repeat Start bit	Address	R(1)	Ack	Data Byte count = X	Ack	Beginning Data Byte (N)	Ack

	8 bits	1 bit	1 bit
.....	Data Byte (N+X-1)	NAck	Stop bit

### Byte 0: Output Enable Register

Bit	Control Function	Description	Type	Power-up Condition	0	1
7	Q7_OE	Q7 output enable	RW	1	See B11[1:0]	Pin Control
6	Q6_OE	Q6 output enable	RW	1		Pin Control
5	Q5_OE	Q5 output enable	RW	1		Pin Control
4	Q4_OE	Q4 output enable	RW	1		Pin Control
3	Q3_OE	Q3 output enable	RW	1		Pin Control
2	Q2_OE	Q2 output enable	RW	1		Pin Control
1	Q1_OE	Q1 output enable	RW	1		Pin Control
0	Q0_OE	Q0 output enable	RW	1		Pin Control

Note:

- A low on these bits will override the OE# pins and force the differential outputs to the state indicated by B11[1:0] (Low/ Low default).

Byte 1: SS Spread Spectrum and Control Register						
Bit	Control Function	Description	Type	Power-up Condition	0	1
7	SSENRB1	SS Enable Readback Bit1	R	Latch	'00' for SS_SEL_TRI = '0', '10' for SS_SEL_TRI = 'M' '11' for SS_SEL_TRI = '1'	
6	SSENRB0	SS Enable Readback Bit0	R	Latch		
5	SSEN_SWCTR	Enable SW control of SS	RW	0	Values in B1[7:6] control SS amount	Values in B1[4:3] control SS amount
4	SSENSW1	SS enable SW control Bit1	RW <sup>(1)</sup>	0	'00' = SS off, '01' = -0.25% SS, '10' = SS off, '11' = -0.5% SS	
3	SSENSW0	SS enable SW control Bit0	RW <sup>(1)</sup>	0		
2	Reserved			1		
1	Amplitude1	Control output amplitude	RW	1	'00' = 0.6V, '01' = 0.68V, '10' = 0.75V, '11' = 0.85V	
0	Amplitude0		RW	0		

Note:

- Spread must be selected OFF or ON with the hardware latch pin. These bits should not be used to turn spread ON or OFF after power up. These bits can be used to change the spread amount, and B1[5] must be set to a 1 for these bits to have any effect on the part. If these bits are used to turn spread OFF or ON, the system must reset.

Byte 2: Differential Output Slew Rate Control Register						
Bit	Control Function	Description	Type	Power-up Condition	0	1
7	SLEWRATECTR_Q7	Control slew rate of Q7	RW	1	Slow setting	Fast setting
6	SLEWRATECTR_Q6	Control slew rate of Q6	RW	1	Slow setting	Fast setting
5	SLEWRATECTR_Q5	Control slew rate of Q5	RW	1	Slow setting	Fast setting
4	SLEWRATECTR_Q4	Control slew rate of Q4	RW	1	Slow setting	Fast setting
3	SLEWRATECTR_Q3	Control slew rate of Q3	RW	1	Slow setting	Fast setting
2	SLEWRATECTR_Q2	Control slew rate of Q2	RW	1	Slow setting	Fast setting
1	SLEWRATECTR_Q1	Control slew rate of Q1	RW	1	Slow setting	Fast setting
0	SLEWRATECTR_Q0	Control slew rate of Q0	RW	1	Slow setting	Fast setting

Byte 3: REF Control Register						
Bit	Control Function	Description	Type	Power-up Condition	0	1
7	REFSLEWRATE	Slew rate control for REF	RW	0	'00' = 1.4V/ns '01' = 2.4V/ns, '10' = 3V/ns, '11' = 3.2V/ns	
6			RW	1		
5	REF_PDSTATE	Wake-on-Lan enable for REF	RW	0	REF = Disabled in PD state <sup>(1)</sup>	REF = running in PD state
4	REF_OE	Output enable for REF	RW	1	REF = Disabled <sup>(1)</sup>	REF = running
3	Reserved			1		
2	Reserved			1		
1	Reserved			1		
0	Reserved			1		

Note:

- The disabled state depends on Byte11[1:0]. '00' = Low, '01'=HiZ, '10'=Low, '11'=High.

Byte 4: Reserved						
Bit	Control Function	Description	Type	Power-up Condition	0	1
7:0	Reserved			0x40		

Byte 5: Revision and Vendor ID Register						
Bit	Control Function	Description	Type	Power-up Condition	0	1
7	RID3	Revision ID	R	0	Rev = 0000	
6	RID2		R	0		
5	RID1		R	0		
4	RID0		R	0		
3	PVID3	Vendor ID	R	0	Diodes = 0011	
2	PVID2		R	0		
1	PVID1		R	1		
0	PVID0		R	1		

**PI6CG33802C**

Byte 6: Device Type/Device ID Register						
Bit	Control Function	Description	Type	Power-up Condition	0	1
7	DTYPE1	Device type	R	0	'00' = CG, '01' = ZDB, '10' = Reserved, '11' = NZDB	
6	DTYPE0		R	0		
5	DID5	Device ID	R	0	001000 binary, 08Hex	
4	DID4		R	0		
3	DID3		R	1		
2	DID2		R	0		
1	DID1		R	0		
0	DID0		R	0		

Byte 7: Byte Count Register						
Bit	Control Function	Description	Type	Power-up Condition	0	1
7	Reserved			0		
6	Reserved			0		
5	Reserved			0		
4	BC4	Byte count programming	RW	0	Writing to this register will configure how many bytes will be read back, default is 8 bytes	
3	BC3		RW	1		
2	BC2		RW	0		
1	BC1		RW	0		
0	BC0		RW	0		

Byte 8 and 9: Reserved						
Bit	Control Function	Description	Type	Power-up Condition	0	1
7:0	Reserved			B8 = 0x36 B9 = 0x00		

Byte 10: PD Restore						
Bit	Control Function	Description	Type	Power-up Condition	0	1
7	Reserved			0		
6	PD Restore	PD restore to default configuration	RW	1	Clear PD Config	Keep PD Config
5:0	Reserved			0		

Byte 11: Stop Control						
Bit	Control Function	Description	Type	Power-up Condition	0	1
7:2	Reserved			0		
1	STP1	True/ Compliment DIF Output Disable Sate	RW	0	00 = Low/Low	10 = High/Low
0	STP0		RW	0	01 = HiZ/HiZ	11 = Low/High

Byte 12: Impedance Control						
Bit	Control Function	Description	Type	Power-up Condition	0	1
7	Q3_Zout1	Q3 Zout	RW	01	00 = Reserved 01 = 85Ω 10 = 100Ω 11 = Reserved	
6	Q3_Zout0	Q3 Zout	RW			
5	Q2_Zout1	Q2 Zout	RW			
4	Q2_Zout0	Q2 Zout	RW			
3	Q1_Zout1	Q1 Zout	RW			
2	Q1_Zout0	Q1 Zout	RW			
1	Q0_Zout1	Q0 Zout	RW			
0	Q0_Zout0	Q0 Zout	RW			

Byte 13: Impedance Control						
Bit	Control Function	Description	Type	Power-up Condition	0	1
7	Q7_Zout1	Q7 Zout	RW	01	00 = Reserved 01 = 85Ω 10 = 100Ω 11 = Reserved	
6	Q7_Zout0	Q7 Zout	RW			
5	Q6_Zout1	Q6 Zout	RW			
4	Q6_Zout0	Q6 Zout	RW			
3	Q5_Zout1	Q5 Zout	RW			
2	Q5_Zout0	Q5 Zout	RW			
1	Q4_Zout1	Q4 Zout	RW			
0	Q4_Zout0	Q4 Zout	RW			



**PI6CG33802C**
**Byte 14: OE Termination Control**

Bit	Control Function	Description	Type	Power-up Condition	0	1
7	OE3_term1	OE3 Pullup or down	RW	0	00 = None	10 = Pullup
6	OE3_term0	OE3 Pullup or down	RW	1	01 = Pull-down	11 = Pullup and Down
5	OE2_term1	OE2 Pullup or down	RW	0	00 = None	10 = Pullup
4	OE2_term0	OE2 Pullup or down	RW	1	01 = Pull-down	11 = Pullup and Down
3	OE1_term1	OE1 Pullup or down	RW	0	00 = None	10 = Pullup
2	OE1_term0	OE1 Pullup or down	RW	1	01 = Pull-down	11 = Pullup and Down
1	OE0_term1	OE0 Pullup or down	RW	0	00 = None	10 = Pullup
0	OE0_term0	OE0 Pullup or down	RW	1	01 = Pull-down	11 = Pullup and Down

**Byte 15: OE Termination Control**

Bit	Control Function	Description	Type	Power-up Condition	0	1
7	OE7_term1	OE7 Pullup or down	RW	0	00 = None	10 = Pullup
6	OE7_term0	OE7 Pullup or down	RW	1	01 = Pull-down	11 = Pullup and Down
5	OE6_term1	OE6 Pullup or down	RW	0	00 = None	10 = Pullup
4	OE6_term0	OE6 Pullup or down	RW	1	01 = Pull-down	11 = Pullup and Down
3	OE5_term1	OE5 Pullup or down	RW	0	00 = None	10 = Pullup
2	OE5_term0	OE5 Pull up or down	RW	1	01 = Pull-down	11 = Pullup and Down
1	OE4_term1	OE4 Pullup or down	RW	0	00 = None	10 = Pullup
0	OE4_term0	OE4 Pullup or down	RW	1	01 = Pull-down	11 = Pullup and Down

**Byte 16: Power Good Termination Control**

Bit	Control Function	Description	Type	Power-up Condition	0	1
7:2	Reserved			0x09		
1	PWRGD_PD1	Clock Power Good and Power Down Pullup or Pulldown	RW	1	00 = None	10 = Pullup
0	PWRGD_PD0		RW	0	01 = Pull-down	11 = Pullup and Down

**Byte 17: Reserved**

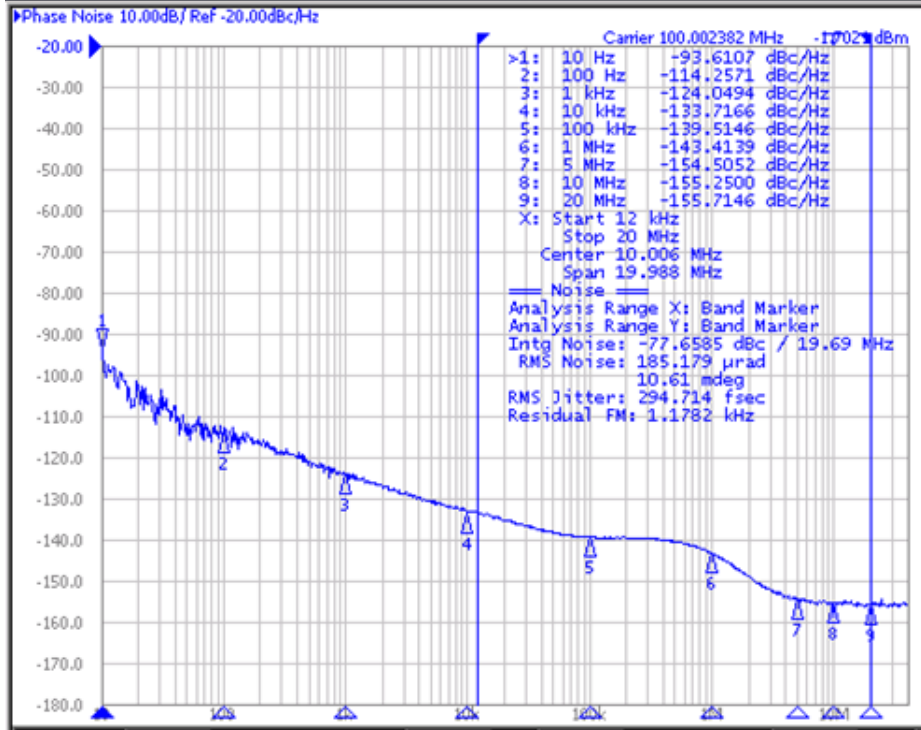
<b>Byte 18: Enable Pin Control</b>						
<b>Bit</b>	<b>Control Function</b>	<b>Description</b>	<b>Type</b>	<b>Power-up Condition</b>	<b>0</b>	<b>1</b>
7	OE7_Enable	Sets Enable High or Low	RW	0	Enable = Low	Enable = High
6	OE6_Enable	Sets Enable High or Low	RW	0	Enable = Low	Enable = High
5	OE5_Enable	Sets Enable High or Low	RW	0	Enable = Low	Enable = High
4	OE4_Enable	Sets Enable High or Low	RW	0	Enable = Low	Enable = High
3	OE3_Enable	Sets Enable High or Low	RW	0	Enable = Low	Enable = High
2	OE2_Enable	Sets Enable High or Low	RW	0	Enable = Low	Enable = High
1	OE1_Enable	Sets Enable High or Low	RW	0	Enable = Low	Enable = High
0	OE0_Enable	Sets Enable High or Low	RW	0	Enable = Low	Enable = High

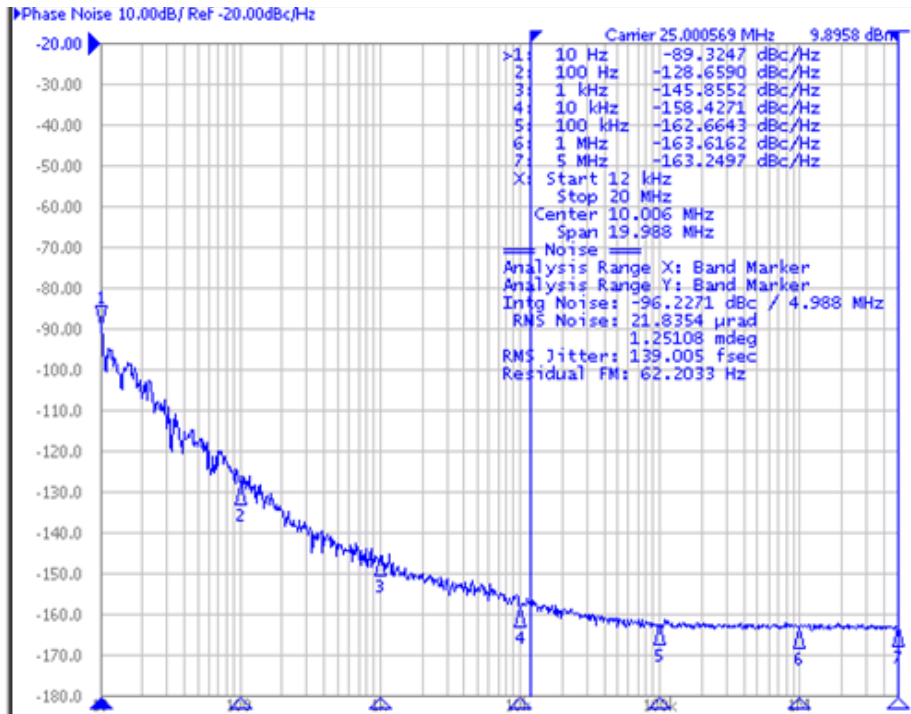
<b>Byte 19: Power Down Pin Control</b>						
<b>Bit</b>	<b>Control Function</b>	<b>Description</b>	<b>Type</b>	<b>Power-up Condition</b>	<b>0</b>	<b>1</b>
7:1	Reserved			0		
0	PWRGD_PD	PWRGD_PD Active via Pullup or Pulldown	RW	0	Power Down = Low	Power Down = High

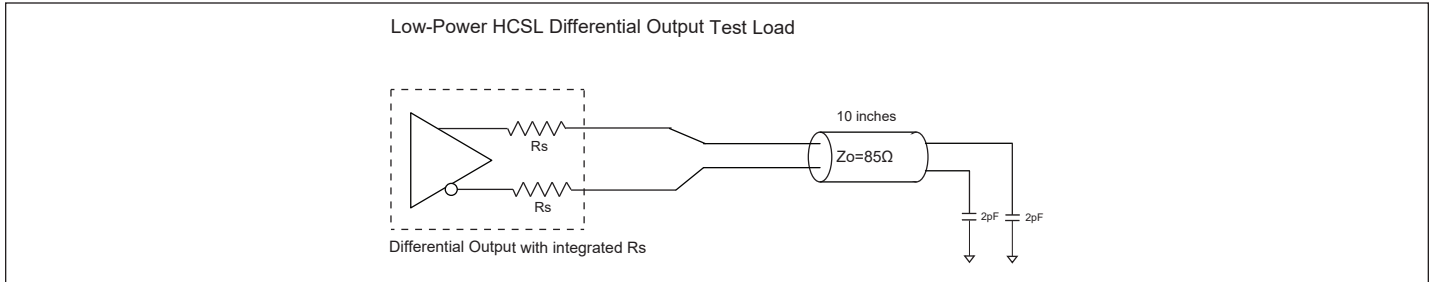
**Plots**

**100MHz HCSL Clock (12k to 20MHz)**

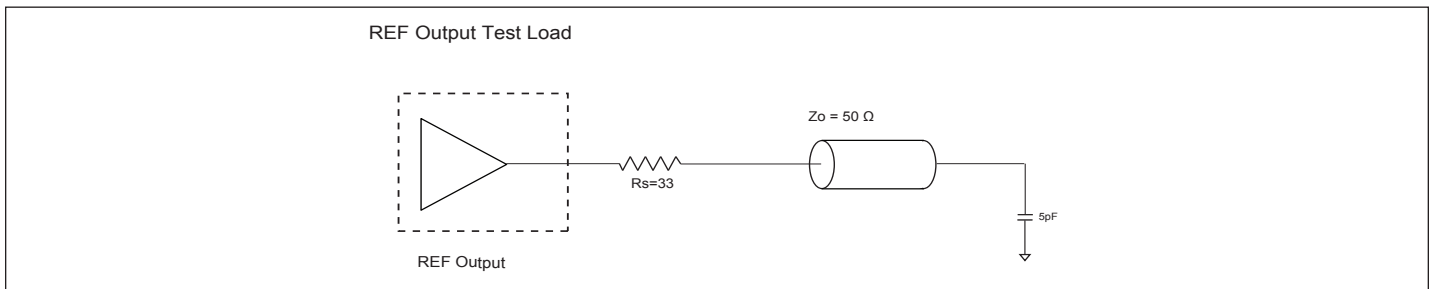


**25MHz CMOS Clock**

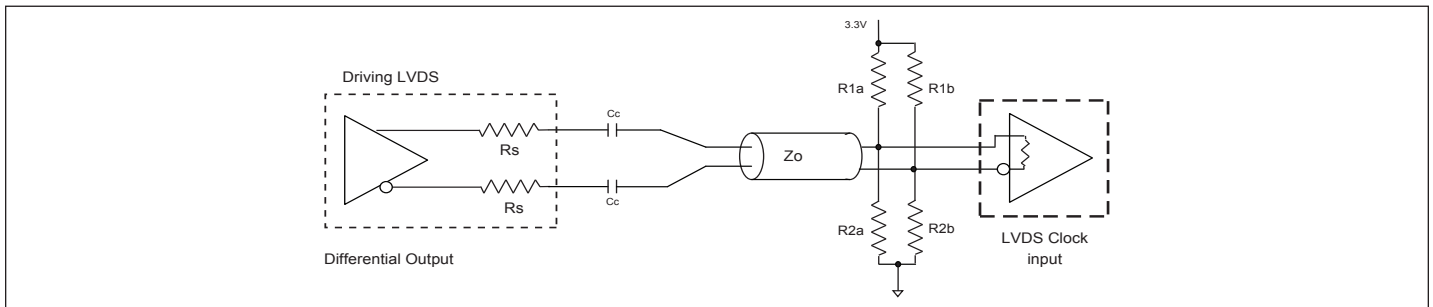




**Figure 1. Low-Power HCSL Test Circuit**



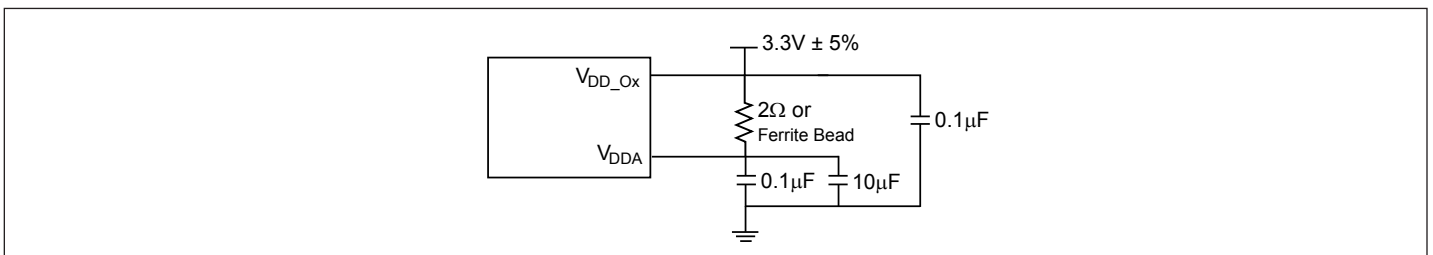
**Figure 2. CMOS REF Test Circuit**



**Figure 3. Differential Output Driving LVDS**

**Table 3. Alternate Differential Output Terminations ( $Z_o = 85\Omega$ )**

Component	Receiver with Termination	Receiver without Termination	Unit
R <sub>1a</sub> , R <sub>1b</sub>	10,000	130	$\Omega$
R <sub>2a</sub> , R <sub>2b</sub>	5600	64	$\Omega$
C <sub>C</sub>	0.1	0.1	$\mu\text{F}$
V <sub>CM</sub>	1.2	1.2	V

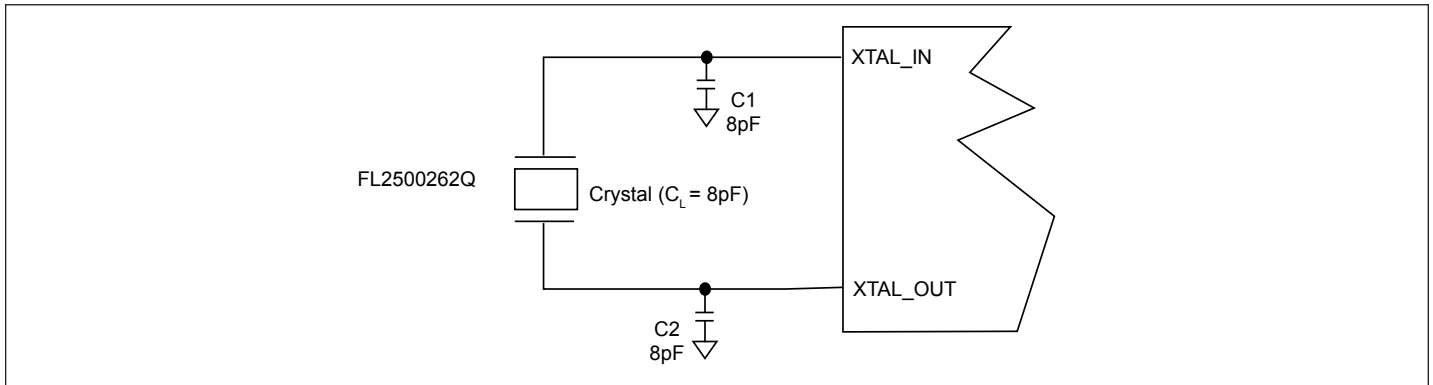


**Figure 4. Power Supply Filter**

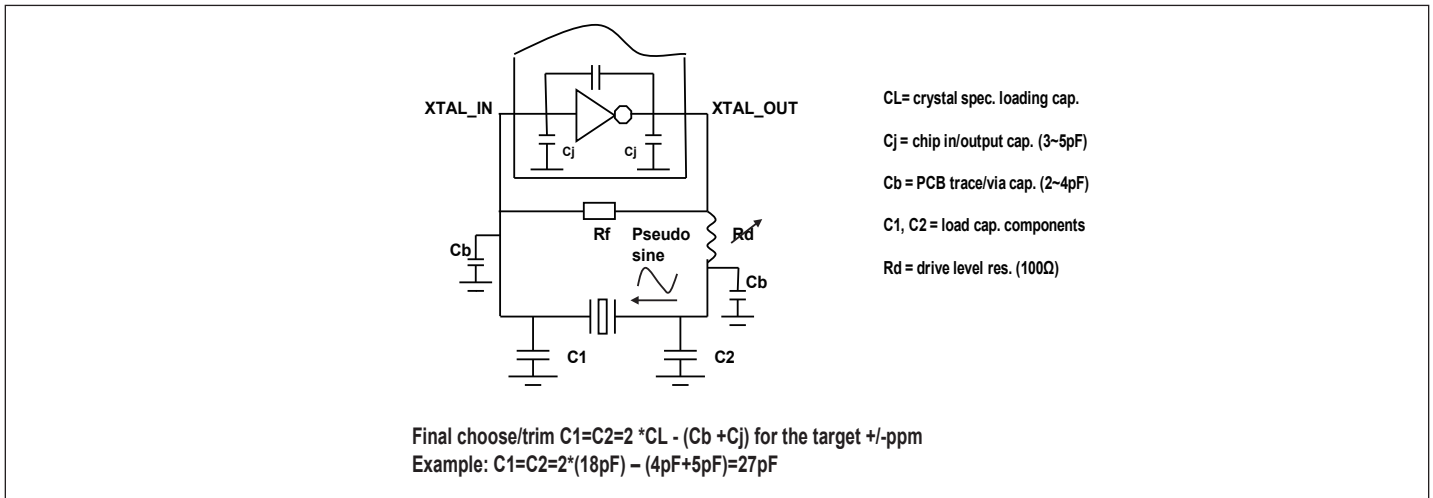
## Crystal Circuit Connection

The following diagram shows PI6CG33802C crystal circuit connection with a parallel crystal. For the  $CL = 8\text{pF}$  crystal, it is suggested to use  $C1 = 8\text{pF}$  and  $C2 = 8\text{pF}$ .  $C1$  and  $C2$  can be adjusted to fine tune to the target ppm of crystal oscillator according to different board layouts based on the following formular in the Crystal Capacitor Calculation diagram.

## Crystal Oscillator Circuit



## Crystal Capacitor Calculation



## Recommended Crystal Specification

### Diodes Recommends:

- FL2500217, SMD 3.2x2.5(4P), 25MHz,  $CL=8\text{pF}$ , +/-20ppm, <https://www.diodes.com/assets/Datasheets/FL.pdf>
- FH2500016, SMD 2.5x2.0(4P), 25MHz,  $CL=8\text{pF}$ , +/-30ppm, <https://www.diodes.com/assets/Datasheets/FH.pdf>
- FW2500031, SMD 2.0x1.6(4P), 25MHz,  $CL=8\text{pF}$ , +/-30ppm, <https://www.diodes.com/assets/Datasheets/FW.pdf>
- US2500003, SMD 1.6x1.2(4P), 25MHz,  $CL=12\text{pF}$ , +/-30ppm, <https://www.diodes.com/assets/Datasheets/US.pdf>

**Table 4. Thermal Characteristics**

Symbol	Parameter	Conditions	Min.	Typ.	Max.	Unit
$\theta_{JA}$	Thermal Resistance Junction to Ambient	Still air			38.15	$^{\circ}\text{C}/\text{W}$
$\theta_{JC}$	Thermal Resistance Junction to Case				24.66	$^{\circ}\text{C}/\text{W}$

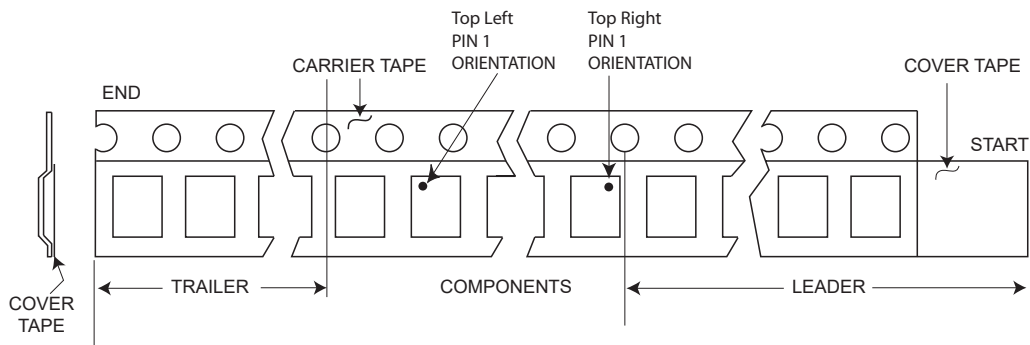
PI6CG33802C

## Part Marking



YY: Year  
 WW: Workweek  
 1st X: Assembly Code  
 2nd X: Fab Code

## Package Information



**Packaging Mechanical**

**48-TQFN (ZL)**

SYMBOLS	MIN.	NOM.	MAX.
A	0.80	0.85	0.90
A1	0.00	0.02	0.05
A3	0.203 REF.		
b	0.15	0.20	0.25
D	5.90	6.00	6.10
E	5.90	6.00	6.10
e	0.40 BSC		
K	0.35 REF.		
D2	4.45	4.50	4.55
E2	4.45	4.50	4.55
L	0.35	0.40	0.45

**NOTE :**

1. ALL DIMENSIONS ARE IN mm. ANGLES IN DEGREES.
2. COPLANARITY APPLIES TO THE EXPOSED THERMAL PAD AS WELL AS THE TERMINALS.
3. REFER JEDEC MO-220
4. RECOMMENDED LAND PATTERN IS FOR REFERENCE ONLY.
5. THERMAL PAD SOLDERING AREA (MESH STENCIL DESIGN IS RECOMMENDED).

**PERICOM**  
Enabling Serial Connectivity

DATE: 10/26/15

DESCRIPTION: 48-Contact, Very Thin Quad Flat No-Lead (TQFN)

PACKAGE CODE: ZL (ZL48)

DOCUMENT CONTROL #: PD-2201

REVISION: A

15-0244

For latest package information:

See <http://www.diodes.com/design/support/packaging/pericom-packaging/packaging-mechanicals-and-thermal-characteristics/>.

**Ordering Information**

Ordering Code	Package Code	Package Description	Pin 1 Location
PI6CG33802CZLIEX	ZL	48-Contact, Very Thin Quad Flat No-Lead (TQFN)	Top Right Corner
PI6CG33802CZLIEX-13R	ZL	48-Contact, Very Thin Quad Flat No-Lead (TQFN)	Top Left Corner

**Notes:**

1. No purposely added lead. Fully EU Directive 2002/95/EC (RoHS), 2011/65/EU (RoHS 2) & 2015/863/EU (RoHS 3) compliant.
2. See <https://www.diodes.com/quality/lead-free/> for more information about Diodes Incorporated's definitions of Halogen- and Antimony-free, "Green" and Lead-free.
3. Halogen- and Antimony-free "Green" products are defined as those which contain <900ppm bromine, <900ppm chlorine (<1500ppm total Br + Cl) and <1000ppm antimony compounds.
4. E = Pb-free and Green
5. X suffix = Tape/Reel
6. For packaging details, go to our website at: <https://www.diodes.com/assets/MediaList-Attachments/Diodes-Package-Information.pdf>

**IMPORTANT NOTICE**

1. DIODES INCORPORATED (Diodes) AND ITS SUBSIDIARIES MAKE NO WARRANTY OF ANY KIND, EXPRESS OR IMPLIED, WITH REGARDS TO ANY INFORMATION CONTAINED IN THIS DOCUMENT, INCLUDING, BUT NOT LIMITED TO, THE IMPLIED WARRANTIES OF MERCHANTABILITY, FITNESS FOR A PARTICULAR PURPOSE OR NON-INFRINGEMENT OF THIRD PARTY INTELLECTUAL PROPERTY RIGHTS (AND THEIR EQUIVALENTS UNDER THE LAWS OF ANY JURISDICTION).
2. The Information contained herein is for informational purpose only and is provided only to illustrate the operation of Diodes' products described herein and application examples. Diodes does not assume any liability arising out of the application or use of this document or any product described herein. This document is intended for skilled and technically trained engineering customers and users who design with Diodes' products. Diodes' products may be used to facilitate safety-related applications; however, in all instances customers and users are responsible for (a) selecting the appropriate Diodes products for their applications, (b) evaluating the suitability of Diodes' products for their intended applications, (c) ensuring their applications, which incorporate Diodes' products, comply the applicable legal and regulatory requirements as well as safety and functional-safety related standards, and (d) ensuring they design with appropriate safeguards (including testing, validation, quality control techniques, redundancy, malfunction prevention, and appropriate treatment for aging degradation) to minimize the risks associated with their applications.
3. Diodes assumes no liability for any application-related information, support, assistance or feedback that may be provided by Diodes from time to time. Any customer or user of this document or products described herein will assume all risks and liabilities associated with such use, and will hold Diodes and all companies whose products are represented herein or on Diodes' websites, harmless against all damages and liabilities.
4. Products described herein may be covered by one or more United States, international or foreign patents and pending patent applications. Product names and markings noted herein may also be covered by one or more United States, international or foreign trademarks and trademark applications. Diodes does not convey any license under any of its intellectual property rights or the rights of any third parties (including third parties whose products and services may be described in this document or on Diodes' website) under this document.
5. Diodes' products are provided subject to Diodes' Standard Terms and Conditions of Sale (<https://www.diodes.com/about/company/terms-and-conditions/terms-and-conditions-of-sales/>) or other applicable terms. This document does not alter or expand the applicable warranties provided by Diodes. Diodes does not warrant or accept any liability whatsoever in respect of any products purchased through unauthorized sales channel.
6. Diodes' products and technology may not be used for or incorporated into any products or systems whose manufacture, use or sale is prohibited under any applicable laws and regulations. Should customers or users use Diodes' products in contravention of any applicable laws or regulations, or for any unintended or unauthorized application, customers and users will (a) be solely responsible for any damages, losses or penalties arising in connection therewith or as a result thereof, and (b) indemnify and hold Diodes and its representatives and agents harmless against any and all claims, damages, expenses, and attorney fees arising out of, directly or indirectly, any claim relating to any noncompliance with the applicable laws and regulations, as well as any unintended or unauthorized application.
7. While efforts have been made to ensure the information contained in this document is accurate, complete and current, it may contain technical inaccuracies, omissions and typographical errors. Diodes does not warrant that information contained in this document is error-free and Diodes is under no obligation to update or otherwise correct this information. Notwithstanding the foregoing, Diodes reserves the right to make modifications, enhancements, improvements, corrections or other changes without further notice to this document and any product described herein. This document is written in English but may be translated into multiple languages for reference. Only the English version of this document is the final and determinative format released by Diodes.
8. Any unauthorized copying, modification, distribution, transmission, display or other use of this document (or any portion hereof) is prohibited. Diodes assumes no responsibility for any losses incurred by the customers or users or any third parties arising from any such unauthorized use.
9. This Notice may be periodically updated with the most recent version available at <https://www.diodes.com/about/company/terms-and-conditions/important-notice>

The Diodes logo is a registered trademark of Diodes Incorporated in the United States and other countries.  
All other trademarks are the property of their respective owners.  
© 2024 Diodes Incorporated. All Rights Reserved.

[www.diodes.com](http://www.diodes.com)