

Features

- Highly accurate: $\pm 1.5\%$ (25 °C)
- Detect voltage range: 1.8 to 5V in 100mV increments
- Operating voltage range: 1.0V ~ 5.5V
- Operating temperature range: -40 °C to + 85 °C
- Detect voltage temperature characteristics: $\pm 2.5\% \times$ TYP
- Output configuration: Bi-dir
- Four reset timeout period available:
 - ◆ typical 1.6ms for PT7M6314USxxD1;
 - ◆ typical 26ms for PT7M6314USxxD2;
 - ◆ typical 200ms for PT7M6314USxxD3;
 - ◆ typical 1570ms for PT7M6314USxxD4;

General Description

The series are designed to monitor power supplies in μ P and digital systems. It provides excellent circuit reliability and low cost by eliminating external components and adjustments, and a debounced manual reset input.

This device performs a single function: it asserts a reset signal whenever the V_{CC} supply voltage falls below a preset threshold or whenever manual reset is asserted. Reset remains asserted for an internally programmed interval (reset timeout period) after V_{CC} has risen above the reset threshold or manual reset is de-asserted.

PT7M6314USxx are bidirectional output, allowing it to be directly connected to μ P with bidirectional reset inputs. The serials come with factory-trimmed reset threshold voltages in 100mV increments from 2.5V to 5V. Preset timeout periods of 200ms and 1570ms (typ.) are available.

Pin Configuration

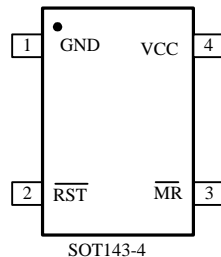

Pin Description

Name	Type	Description
\overline{RST}	I/O	Reset Output and Pushbutton Input: \overline{RST} is asserted when V_{CC} drops below voltage threshold V_{TH} . Active low. When other devices pull \overline{RST} low, the device will speed its rising edge once the reset condition release.
\overline{MR}	I	Manual Reset: A logic low on \overline{MR} asserts reset. Reset remains asserted as long as \overline{MR} is low, and for the reset timeout period (t_{RS}) after the reset conditions are terminated. Connect to V_{CC} if not used.
GND	P	Ground
V_{CC}	P	Supply Voltage.

Maximum Ratings

Storage Temperature	-65°C to +150°C
Ambient Temperature with Power Applied	-40°C to +85°C
Supply Voltage to Ground Potential (V _{CC} to GND)	-0.3V to +7.0V
DC Input Voltage (All inputs except V _{CC} and GND).....	-0.3V to V _{CC} +0.3V
DC Output Current (All outputs)	30mA
Power Dissipation	320mW (Depend on package)

Note:

Stresses greater than those listed under MAXIMUM RATINGS may cause permanent damage to the device. This is a stress rating only and functional operation of the device at these or any other conditions above those indicated in the operational sections of this specification is not implied. Exposure to absolute maximum rating conditions for extended periods may affect reliability.

DC Electrical Characteristics

(T_A = -40~85 °C, unless otherwise noted. Typical values are at T_A = +25 °C)

Description		Sym.	Test Conditions	Min.	Typ.	Max.	Unit
Supply Voltage		V _{CC}		1.0		5.5	V
Supply Current		I _{CC}	V _{CC} = 5.5V. No load.			12	μA
			V _{CC} = 3.6V. No load.			10	μA
Voltage Threshold		V _{TH-}	+25°C	(V _{TH-}) ×0.985	V _{TH-}	(V _{TH-}) ×1.015	V
			-40°C~85°C	(V _{TH-}) ×0.975	V _{TH-}	(V _{TH-}) ×1.025	
Hysteresis		V _{HYS}	V _{TH+} - V _{TH-} *		50		mV
Output Driving	Output low	V _{OL}	I _{OH} = 8mA, V _{CC} = 5V			0.4	V
			I _{OH} = 4mA, V _{CC} = 3V			0.3	
			I _{OH} = -50μA, V _{CC} = 1V			0.09	
Internal pull-up resistor		R _P	$\overline{\text{MR}}$	32	63	100	kΩ
			$\overline{\text{RST}}$ pin. V _{CC} = 3V.	-	11	20	kΩ
			$\overline{\text{RST}}$ pin. V _{CC} = 5V.	-	5	10	
Input High Voltage		V _{IH}	$\overline{\text{MR}}$	V _{CC} < 4V	0.7×V _{CC}		V
			V _{CC} > 4V	2.4			
Input Low Voltage		V _{IL}	$\overline{\text{MR}}$	V _{CC} < 4V		0.3×V _{CC}	V
			V _{CC} > 4V			0.8	
RST active pull-up enable threshold		V _{THUP}	V _{CC} = 5V	0.7	0.9	1.2	V
RST active pull-up current			V _{CC} = 3.3V		20		mA

Note: V_{TH-} is voltage threshold when V_{CC} falls from high to low. V_{TH+} is voltage threshold when V_{CC} rises from low to high.

AC Electrical Characteristics

Timing diagram

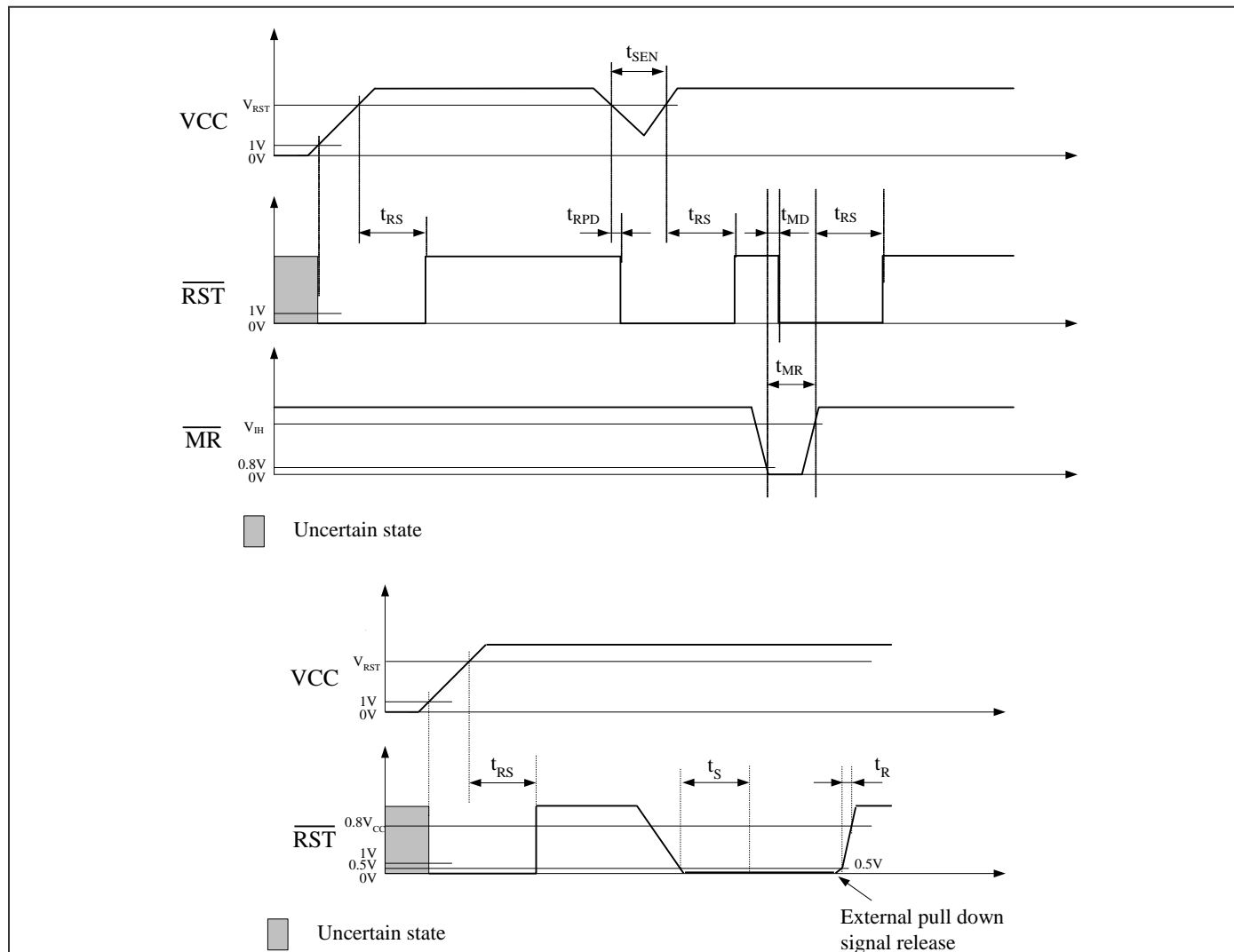

(V_{CC} = 1.0V to 5.5V, T_A = -40~85 °C, unless otherwise noted. Typical values are at T_A = +25 °C)

Sym.	Description	Test Conditions	Part No.	Min.	Typ.	Max.	Unit
t _{RS}	Reset Timeout Period		6314USxxD1	1	1.6	2.2	ms
			6314USxxD2	17	26	40	ms
			6314USxxD3	140	200	280	ms
			6314USxxD4	1120	1570	2240	ms
t _{RPD}	Delay			10		ns	
t _{SEN}	Sensitivity			20		μs	
t _{MD}	MR to Reset Delay				500	ns	
t _{MR}	MR Pulse Width			1		μs	
t _S	External Pull Down Signal Pulse	RST pin		1			μs
t _R	RST Output Rise Time	V _{CC} = 3V	C _{LOAD} = 120pF			333	ns
			C _{LOAD} = 250pF			666	
		V _{CC} = 5V	C _{LOAD} = 200pF			333	
			C _{LOAD} = 400pF			666	

Block Diagram

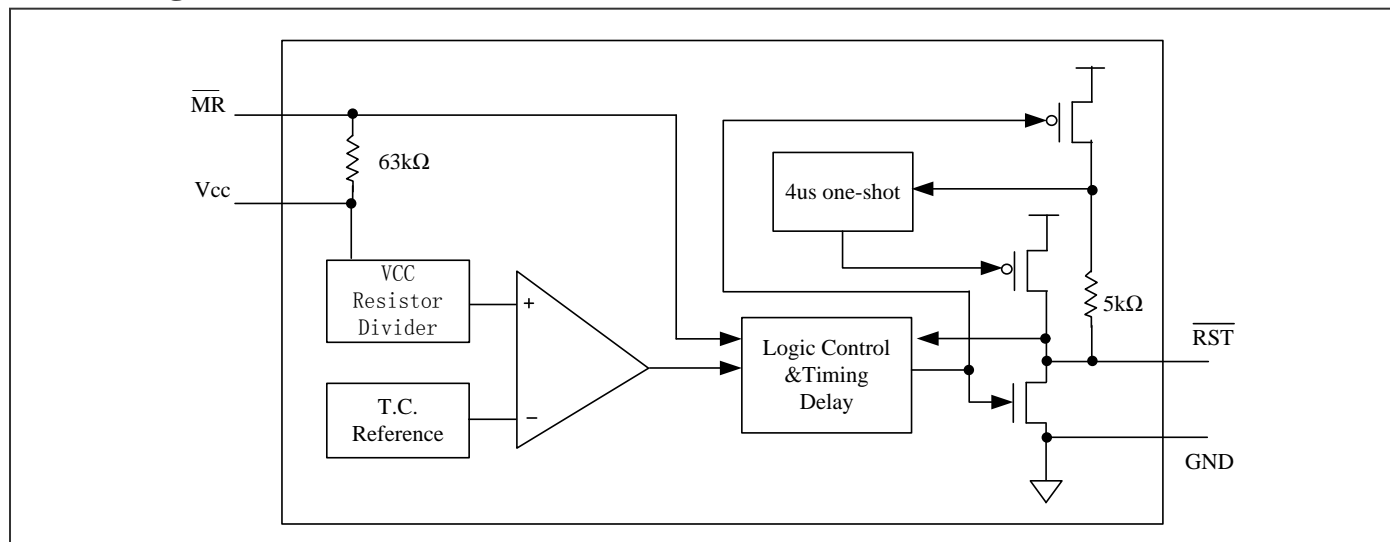

Function Description

Power Monitor

A microprocessor's (μP 's) reset input starts the μP in a known state. Whenever the μP is in an unknown state, it should be held in reset. The supervisory circuits assert reset during power-up and prevent code execution errors during power-down or brownout conditions.

On power-up, once V_{CC} reaches about 1.0V, $\overline{\text{RST}}$ is a guaranteed logic low of 0.4V or less. As V_{CC} rises, $\overline{\text{RST}}$ stays low. When V_{CC} rises above the reset threshold V_{RST} , an internal timer releases $\overline{\text{RST}}$ after about 1570ms (PT7M6314USxxD4). $\overline{\text{RST}}$ asserts whenever V_{CC} drops below the reset threshold, i.e. brownout condition. If brownout occurs in the middle of a previously initiated reset pulse, the pulse continues for at least another 1.6ms or 26ms or 200ms or 1570ms (PT7M6314USxxD4). On power-down, once V_{CC} falls below the reset threshold, $\overline{\text{RST}}$ stays low and is guaranteed to be 0.4V or less until V_{CC} drops below 1V.

Manual Reset

The manual-reset input ($\overline{\text{MR}}$) allows reset to be triggered by a pushbutton switch. The switch is effectively debounced by the 1.6ms (PT7M6314USxxD1) or 26ms (PT7M6314USxxD2) or 200ms (PT7M6314USxxD3) or 1570ms (PT7M6314USxxD4) reset pulse width.

Reset Output: Bi-direction

The PT7M6314USxx's RESET output is designed to interface with μP s that have bidirectional reset pins, such as the Motorola 68HC11. Like an open-drain output, the PT7M6314USxx allows the μP or other devices to pull $\overline{\text{RST}}$ low and assert a reset condition. However, unlike a standard open-drain output, it includes the commonly specified 5k Ω pull-up resistor with a P-channel active pull-up in parallel. This structure can speed the rising edge when the reset condition releases. The reset condition will occur when V_{CC} drops below the reset threshold, or Manual Reset is set to ground, or $\overline{\text{RST}}$ is pulled down.

Application Information

Typical Operation Circuit

Fig 6. PT7M6314USxx Application Example

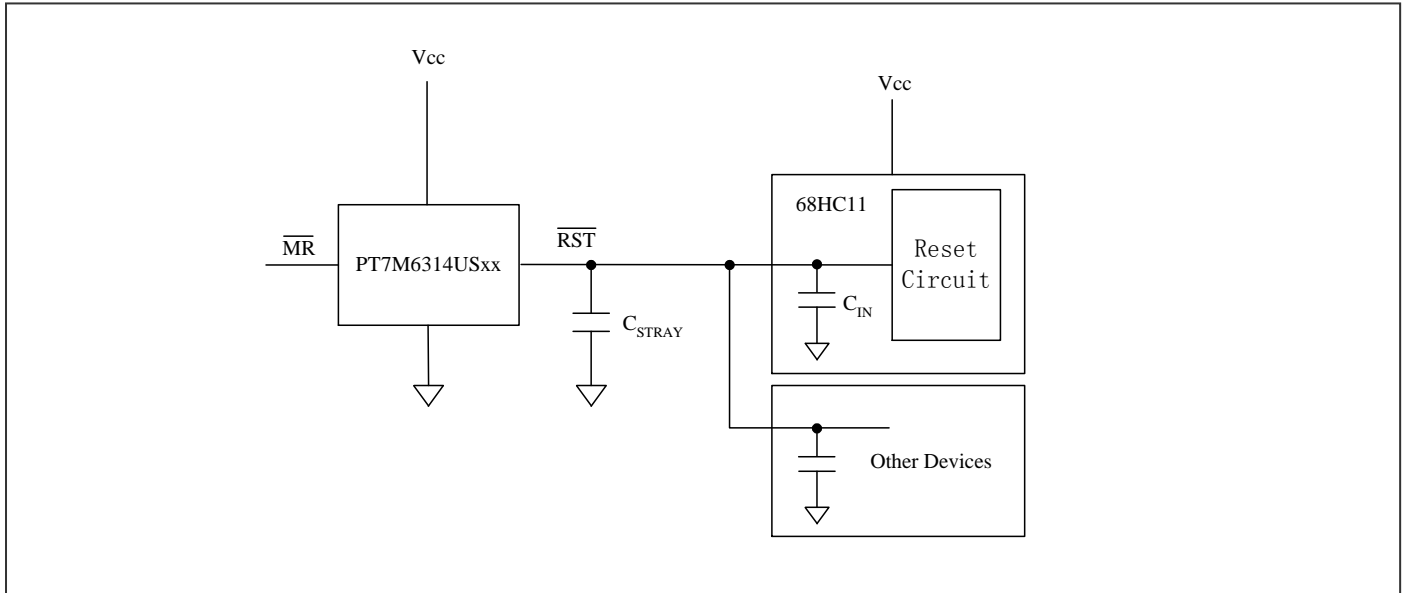

Mechanical Information

SOT143-4

PKG. DIMENSIONS(MM)		
SYMBOL	Min	Max
A	0.90	1.15
A1	0.00	0.10
A2	0.90	1.05
b	0.30	0.50
b1	0.75	0.90
c	0.08	0.15
D	2.80	3.00
d	0.20 TYP	
E	1.20	1.40
E1	2.25	2.55
e	0.95 TYP	
e1	1.80	2.00
L	0.30	0.50
theta	0°	8°

Note:
1. Ref: JEDEC TO-253D

PERICOM Enabling Serial Connectivity	DATE: 06/18/13
DESCRIPTION: 4-Pin, SOT143	
PACKAGE CODE: TB (TB4)	
DOCUMENT CONTROL#: PD-2146	REVISION: -

Ordering Information

Part Number	Package Code	Package
PT7M6314USxxD1TBEX	TB	Lead free and Green SOT143-4, Tape & Reel
PT7M6314USxxD2TBEX	TB	Lead free and Green SOT143-4, Tape & Reel
PT7M6314USxxD3TBEX	TB	Lead free and Green SOT143-4, Tape & Reel
PT7M6314USxxD4TBEX	TB	Lead free and Green SOT143-4, Tape & Reel

Note:

- “xx” refer to voltage range, see below table 1.
- E=Lead-free and Green Packaging
- Adding X suffix=Tape/Reel
- Contact Pericom for availability.

Table 1 Suffix “xx” definition of PT7M6314USxx

Suffix xx	V _{TH} (V)	Suffix xx	V _{TH} (V)	Suffix xx	V _{TH} (V)	Suffix xx	V _{TH} (V)
25	2.5	32	3.2	39	3.9	46	4.6
26	2.6	33	3.3	40	4.0	47	4.7
27	2.7	34	3.4	41	4.1	48	4.8
28	2.8	35	3.5	42	4.2	49	4.9
29	2.9	36	3.6	43	4.3	50	5.0
30	3.0	37	3.7	44	4.4		
31	3.1	38	3.8	45	4.5		

SOT-143 Package Top Marking Instruction

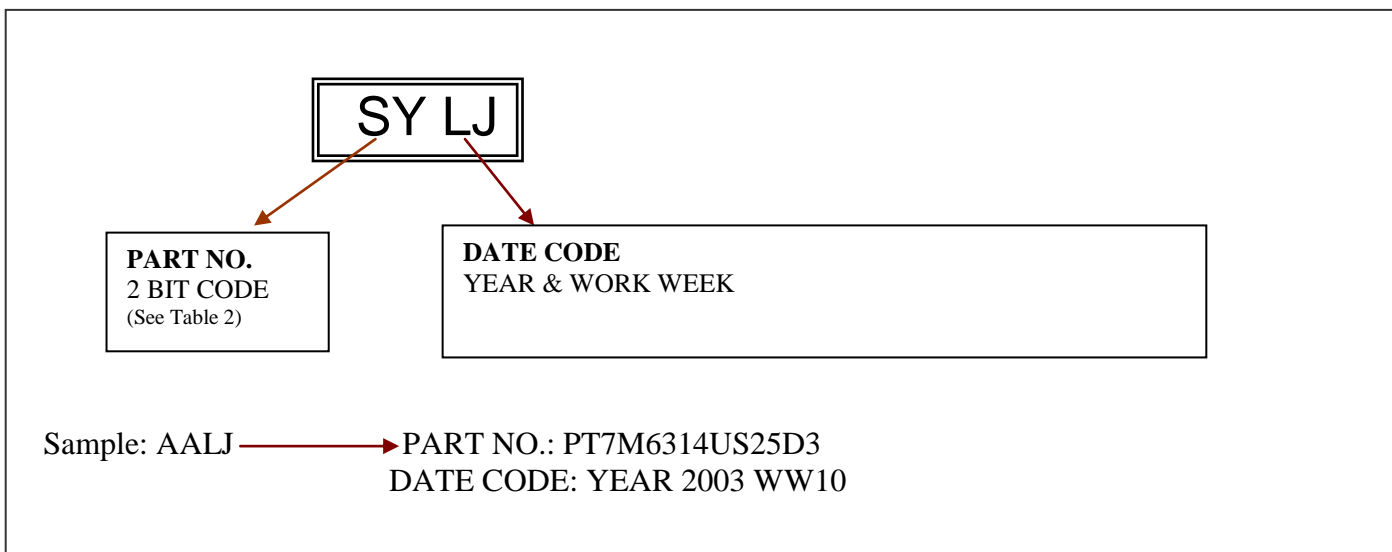

Table2

Part No.	Code	Part No.	Code	Part No.	Code
PT7M6314US25D3	SY	PT7M6314US34D3	UI	PT7M6314US43D3	VS
PT7M6314US25D4	SZ	PT7M6314US34D4	UJ	PT7M6314US43D4	VT
PT7M6314US26D3	TC	PT7M6314US35D3	UM	PT7M6314US44D3	VW
PT7M6314US26D4	TD	PT7M6314US35D4	UN	PT7M6314US44D4	VX
PT7M6314US27D3	TG	PT7M6314US36D3	UQ	PT7M6314US45D3	WA
PT7M6314US27D4	TH	PT7M6314US36D4	UR	PT7M6314US45D4	WB
PT7M6314US28D3	TK	PT7M6314US37D3	UU	PT7M6314US46D3	WE
PT7M6314US28D4	TL	PT7M6314US37D4	UV	PT7M6314US46D4	WF
PT7M6314US29D3	TO	PT7M6314US38D3	UY	PT7M6314US47D3	WI
PT7M6314US29D4	TP	PT7M6314US38D4	UZ	PT7M6314US47D4	WJ
PT7M6314US30D3	TS	PT7M6314US39D3	VC	PT7M6314US48D3	WM
PT7M6314US30D4	TT	PT7M6314US39D4	VD	PT7M6314US48D4	WN
PT7M6314US31D3	TW	PT7M6314US40D3	VG	PT7M6314US49D3	WQ
PT7M6314US31D4	TX	PT7M6314US40D4	VH	PT7M6314US49D4	WR
PT7M6314US32D3	UA	PT7M6314US41D3	VK	PT7M6314US50D3	WU
PT7M6314US32D4	UB	PT7M6314US41D4	VL	PT7M6314US50D4	WV
PT7M6314US33D3	UE	PT7M6314US42D3	VO		
PT7M6314US33D4	UF	PT7M6314US42D4	VP		

IMPORTANT NOTICE

1. DIODES INCORPORATED (Diodes) AND ITS SUBSIDIARIES MAKE NO WARRANTY OF ANY KIND, EXPRESS OR IMPLIED, WITH REGARDS TO ANY INFORMATION CONTAINED IN THIS DOCUMENT, INCLUDING, BUT NOT LIMITED TO, THE IMPLIED WARRANTIES OF MERCHANTABILITY, FITNESS FOR A PARTICULAR PURPOSE OR NON-INFRINGEMENT OF THIRD PARTY INTELLECTUAL PROPERTY RIGHTS (AND THEIR EQUIVALENTS UNDER THE LAWS OF ANY JURISDICTION).
2. The Information contained herein is for informational purpose only and is provided only to illustrate the operation of Diodes' products described herein and application examples. Diodes does not assume any liability arising out of the application or use of this document or any product described herein. This document is intended for skilled and technically trained engineering customers and users who design with Diodes' products. Diodes' products may be used to facilitate safety-related applications; however, in all instances customers and users are responsible for (a) selecting the appropriate Diodes products for their applications, (b) evaluating the suitability of Diodes' products for their intended applications, (c) ensuring their applications, which incorporate Diodes' products, comply the applicable legal and regulatory requirements as well as safety and functional-safety related standards, and (d) ensuring they design with appropriate safeguards (including testing, validation, quality control techniques, redundancy, malfunction prevention, and appropriate treatment for aging degradation) to minimize the risks associated with their applications.
3. Diodes assumes no liability for any application-related information, support, assistance or feedback that may be provided by Diodes from time to time. Any customer or user of this document or products described herein will assume all risks and liabilities associated with such use, and will hold Diodes and all companies whose products are represented herein or on Diodes' websites, harmless against all damages and liabilities.
4. Products described herein may be covered by one or more United States, international or foreign patents and pending patent applications. Product names and markings noted herein may also be covered by one or more United States, international or foreign trademarks and trademark applications. Diodes does not convey any license under any of its intellectual property rights or the rights of any third parties (including third parties whose products and services may be described in this document or on Diodes' website) under this document.
5. Diodes' products are provided subject to Diodes' Standard Terms and Conditions of Sale (<https://www.diodes.com/about/company/terms-and-conditions/terms-and-conditions-of-sales/>) or other applicable terms. This document does not alter or expand the applicable warranties provided by Diodes. Diodes does not warrant or accept any liability whatsoever in respect of any products purchased through unauthorized sales channel.
6. Diodes' products and technology may not be used for or incorporated into any products or systems whose manufacture, use or sale is prohibited under any applicable laws and regulations. Should customers or users use Diodes' products in contravention of any applicable laws or regulations, or for any unintended or unauthorized application, customers and users will (a) be solely responsible for any damages, losses or penalties arising in connection therewith or as a result thereof, and (b) indemnify and hold Diodes and its representatives and agents harmless against any and all claims, damages, expenses, and attorney fees arising out of, directly or indirectly, any claim relating to any noncompliance with the applicable laws and regulations, as well as any unintended or unauthorized application.
7. While efforts have been made to ensure the information contained in this document is accurate, complete and current, it may contain technical inaccuracies, omissions and typographical errors. Diodes does not warrant that information contained in this document is error-free and Diodes is under no obligation to update or otherwise correct this information. Notwithstanding the foregoing, Diodes reserves the right to make modifications, enhancements, improvements, corrections or other changes without further notice to this document and any product described herein. This document is written in English but may be translated into multiple languages for reference. Only the English version of this document is the final and determinative format released by Diodes.
8. Any unauthorized copying, modification, distribution, transmission, display or other use of this document (or any portion hereof) is prohibited. Diodes assumes no responsibility for any losses incurred by the customers or users or any third parties arising from any such unauthorized use.
9. This Notice may be periodically updated with the most recent version available at <https://www.diodes.com/about/company/terms-and-conditions/important-notice>

The Diodes logo is a registered trademark of Diodes Incorporated in the United States and other countries.

All other trademarks are the property of their respective owners.

© 2023 Diodes Incorporated. All Rights Reserved.

www.diodes.com