

## NTC+LCD Heating Controller

### Features

- LCD screen showing temperature setting
- Dual Temperature (Fahrenheit/Centigrade) Display
- Backlights indicating work status
- Auto temperature control with NTC
- NTC open protection
- Pulse trigger for high current SCR (up to 15mA)
- Auto power off.
- Dual Voltage (120V/240V) operations
- Internal 5V zener
- Package: SOIC-24, TQFN-24 and TSSOP-24 package

### Applications

- Heating Controller

### Description

The PT8A3362H is a mixed signal CMOS LSI chip designed as heating controller with help of external NTC (Negative Temperature Component). NTC open protection is implemented for device safety and 11 temperature levels. It can drive SCR directly. It has 3 keys function setting. LCD displays and backlight indicate the working status.

This device can be used in both 120V and 240V power line supplier, as it will automatically adjust the heating power according to the power line voltage to avoid heating appliance damage or long heating time.

The PT8A3362H build-in timer will be auto-power off after power on 1 hour both 60Hz and 50Hz.

### Block Diagram

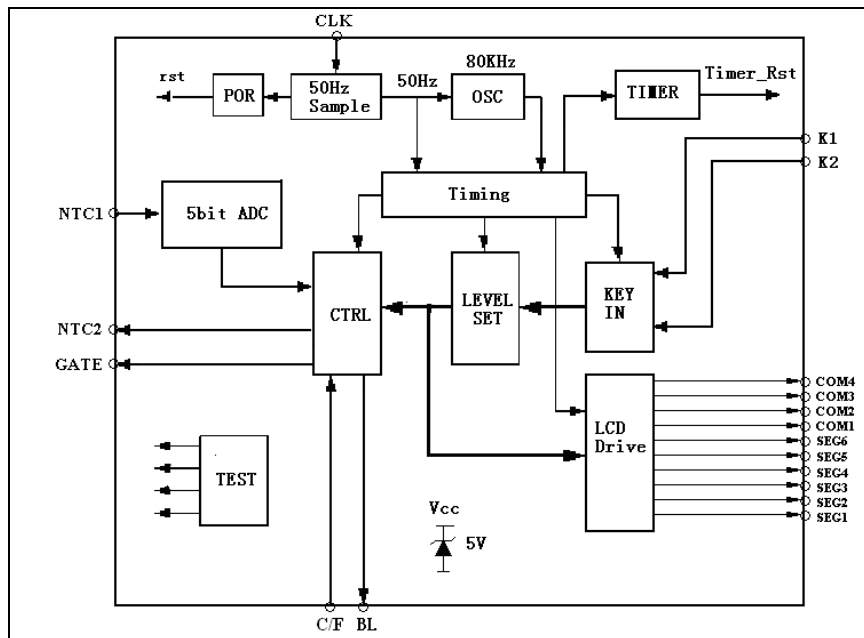

**Table 1 Function Comparison Table**

P/N	Timer(1H)	Keep TEMP Setting	TEMP Step	TEMP(°C)	LCD Backlight	LCD Pin	°C/F Change for UP/DOWN Key
PT8A3362H	Y	N	11	100-200	1	10	N
			11	130-230			
			11	120-220			
			8	160-230			

**Note:**

**Keep TEMP Setting:** Push on/off button to heating-off without power-off then push on/off button to heating-on, the level of temperature setting selected is as former setting before heating-off.

### Pin Configuration

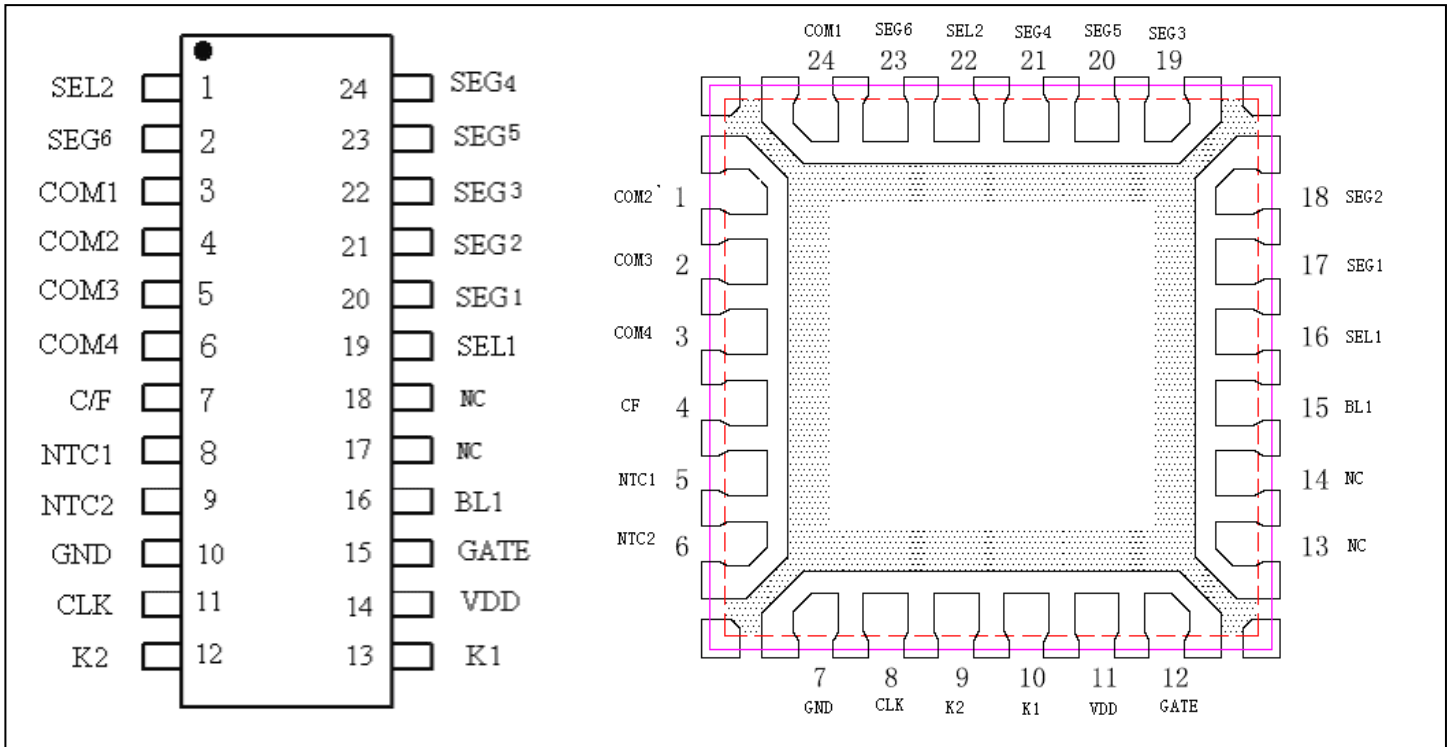

### Pin Description

Name	Pin No.		Type	Description
	SOIC-24/ TSSOP-24	TQFN-24		
SEL2,SEL1	1, 19	22, 16	I	Select temperature setting: 00: 100°C~200°C; 01: 130°C~230°C;10: 120°C~220°C; 11: 160°C~230°C.
SEG1,SEG2, SEG3,SEG4, SEG5,SEG6,	20, 21, 22, 24, 23, 2	17,18,19, 21,20,23	O	LCD digits control output.
COM1,COM2, COM3,COM4	3,4,5,6	24, 1, 2, 3	O	LCD digits control output.
C/F	7	4	I	Internal pull up, default for LCD shows °C; Low level: LCD shows °F.
NTC1	8	5	I	NTC voltage input, NTC open detection input.
NTC2	9	6	O	Output signal for NTC open detection.
GND	10	7	Power	Ground.
CLK	11	8	I	Clock input from power line.
K2	12	9	I	Power on/off key inputs.
K1	13	10	I	Up and down key inputs.
VDD	14	11	Power	Power.
GATE	15	12	O	SCR trigger output.
BL1	16	15	O	Drive LCD backlight.
NC	17, 18	13, 14	-	No connection.

## Function Description

The PT8A3362H is a mixed signal CMOS LSI chip designed as heating controller with help of external NTC (Negative Temperature Component). NTC open protection is implemented for device safety and 11 temperature levels 100°C, 110°C, 120°C, 130°C, 140°C, 150°C, 160°C, 170°C, 180°C, 190°C, 200°C. It can drive SCR directly. It has 3 keys function setting. LCD displays and backlight indicate the working status.

This device can be used in both 120V and 240V power line supplier, as it will automatically adjust the heating power according to the power line voltage to avoid heating appliance damage or long heating time.

The PT8A3362H build-in timer will be auto-power off after power on 1 hour both 60Hz and 50Hz.

Temperature setting is as below:

Pin C/F is pulled to low level. Unit: °F

For PT8A3362H:

SEL2	SEL1	Level 1	Level 2	Level 3	Level 4	Level 5	Level 6	Level 7	Level 8	Level 9	Level 10	Level 11
0	0	210	230	250	265	285	300	320	340	355	375	395
0	1	265	285	300	320	340	355	375	395	410	430	445
1	0	250	265	285	300	320	340	355	375	395	410	430
1	1	320	340	355	375	395	410	430	445	\	\	\

Pin C/F is pulled to high level. Unit: °C

For PT8A3362H:

SEL2	SEL1	Level 1	Level 2	Level 3	Level 4	Level 5	Level 6	Level 7	Level 8	Level 9	Level 10	Level 11
0	0	100	110	120	130	140	150	160	170	180	190	200
0	1	130	140	150	160	170	180	190	200	210	220	230
1	0	120	130	140	150	160	170	180	190	200	210	220
1	1	160	170	180	190	200	210	220	230	\	\	\

### 1 Input Button

**On/Off:** This button will toggle Heating-on or Heating-off.

2). Once heating-on, the level of temperature setting selected is as below:

For PT8A3362H

SEL2	SEL1	Pin C/F :low	Pin C/F :High
0	0	300°F	150 °C
0	1	355°F	180 °C
1	0	340°F	170 °C
1	1	395°F	200 °C

**Up:** Temperature up adjusts. Push Up button once, the temperature setting will increase one level until the highest level is reached.

**Down:** Temperature down adjusts. Push Down button once, the temperature setting will reduce one level until the lowest level is reached.

### 2 LCD Indicator

Default described:

The display on LCD indicates the temperature settings.

During heating-up, LCD flashes, its frequency is 1.5Hz. When the temperature reaches 27 °F -45 °F (15 °C -25 °C) less than the level of temperature setting, LCD will turn always on.

When adjust from low temperature setting level to high, LCD will flash twice. Its frequency is 1.5Hz.

#### Class for LCD indicator

P/N		PT8A3362H
Heating-UP level	LCD Number	Flash for 1.5Hz
	LCD Signal bar	\
TEMP setting adjust	LCD Number	Up for flash twice Down to ON
	LCD Signal bar	\
TEMP Keep	LCD Number	ON
	LCD Signal bar	\
Heating-Down level	LCD Number	ON
	LCD Signal bar	\

**3 Reset**

After power on, the chip will be reset by internal POR circuit, LCD is disabled. GATE and Backlight pins output low level.

**4 LCD Backlight**

Pin BL1 is high under heating-on state, and low under heating-off state.

**5 Timer**

Once IC enters Heating-on state, internal timer will start to count. It'll be timeout and auto heating-off about 1 hour both 60Hz and 50Hz.

**6 Control signal output**

When working in Heating-on state, Gate output will be related to NTC1 input and CLK input amplitude.

1) Effect of NTC and  $V_{T_{CLK}}$  (Level 2) on GATE

Working State	CLK input voltage	NTC (NTC open detection)	NTC (Normal temp detection)	GATE (trigger to SCR)	LCD
ON	High for level 2 (240V)	$V_{NTCO} \sim V_{DD}$	Temperature lower than 90% settings	25%	Normal
			Temperature between 90% to 100% settings	12.5%	
			Temperature is reached settings	0	
	Low for level 2 (120V)		Temperature lower than 90% settings	100%	
			Temperature between 90% to 100% settings	50%	
			Temperature is reached settings	0	
Off	X*		X	0	Display off
ON	X	$0 \sim V_{NTCO}$	X	0	(flashes, its frequency is 3Hz)

\*Note: 1) X means any input.

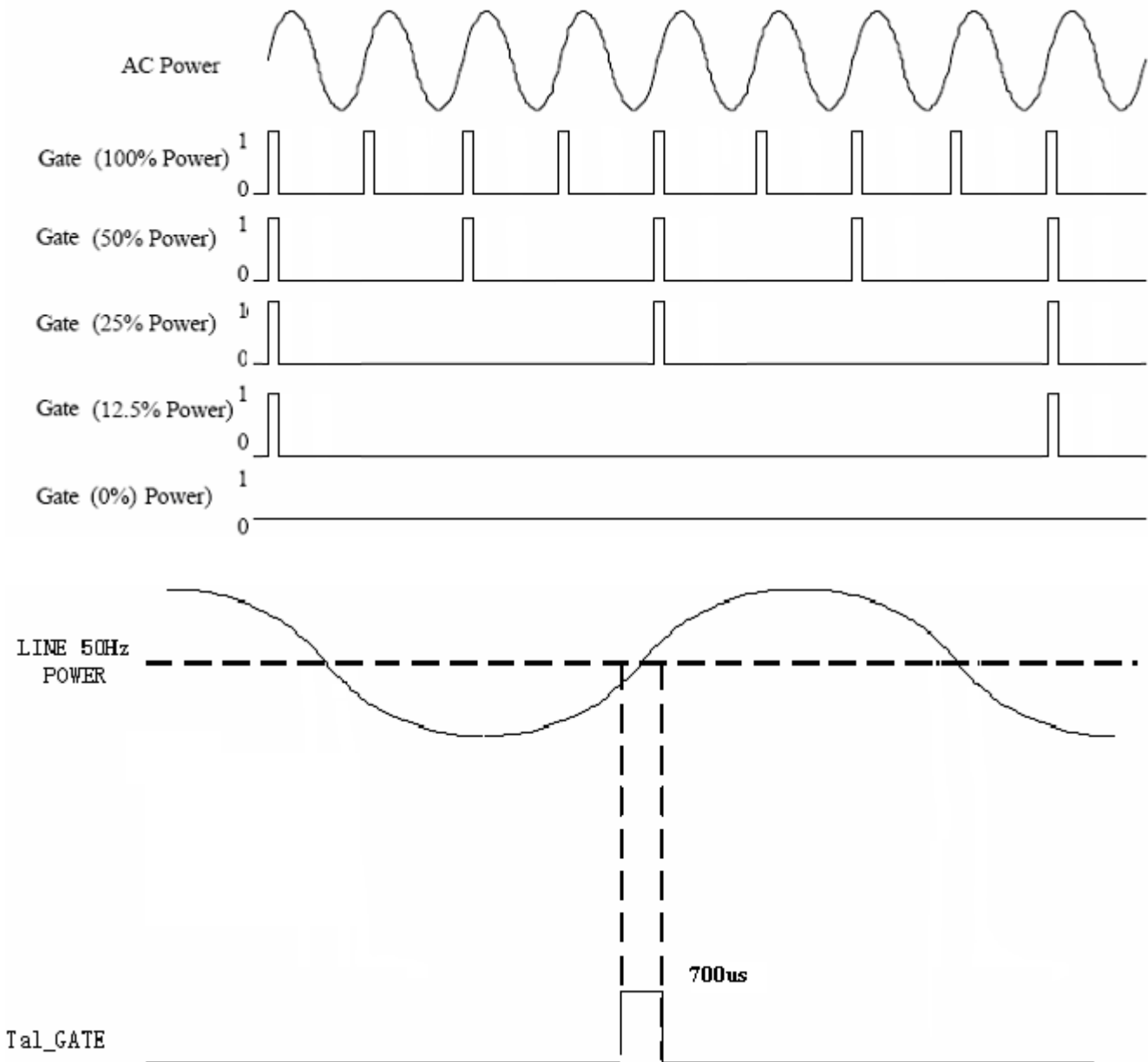
**Effect of NTC and Pulse Trigger on GATE**

- a. High trigger peak current (>20mA), enough trigger 20A SCR
- b. Pulse triggering current to reduce the false self trigger by the leakage of SCR at high temperature environment.
- c. Tal\_GATE = 700µs

**LCD Panel Specification**

Front Polarizer: Transmissive, Adhesive  
 Polarizer Mode: Transflective/Positive  
 Storage Temp : -10°C to +80°C  
 Operating Temp : 0°C to +80°C  
 Viewing Direction : 6 O'CLOCK  
 Drive Condition : 1/4 Duty, 1/3 Bias, 5V  
 Display Mode : TN, Positive Mode  
 $V_{rms\_on} = 0.577V_{DD}$   
 $V_{rms\_off} = 0.236V_{DD}$

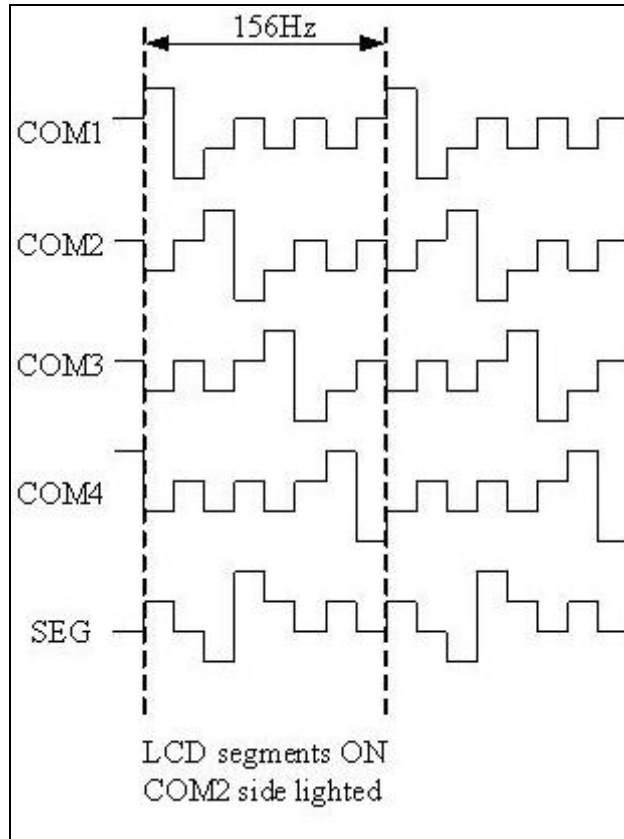
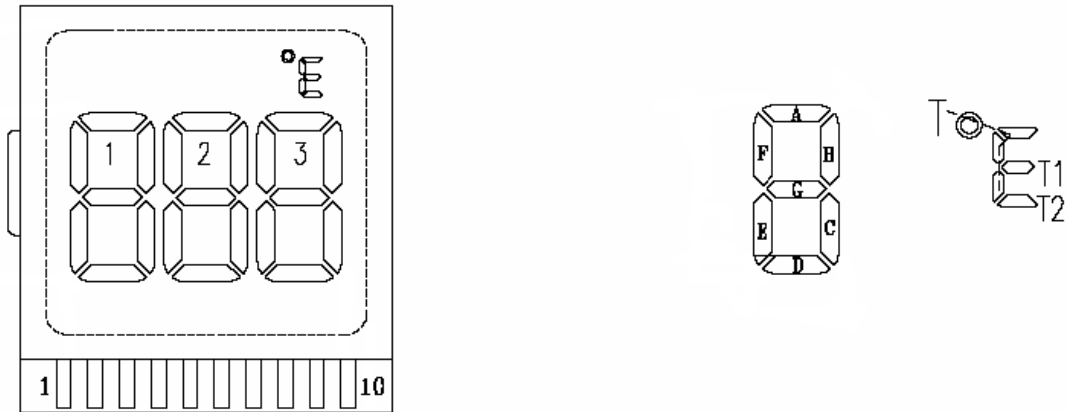
**1) LCD signaling**

**2) Support 10 PIN 5V LCD**

Pin	1	2	3	4	5	6	7	8	9	10
COM4	T	1D	T1	2D	T2	3D				COM4
COM3	1E	1C	2E	2C	3E	3C			COM3	
COM2	1G	1B	2G	2B	3G	3B		COM2		
COM1	1F	1A	2F	2A	3F	3A	COM1			

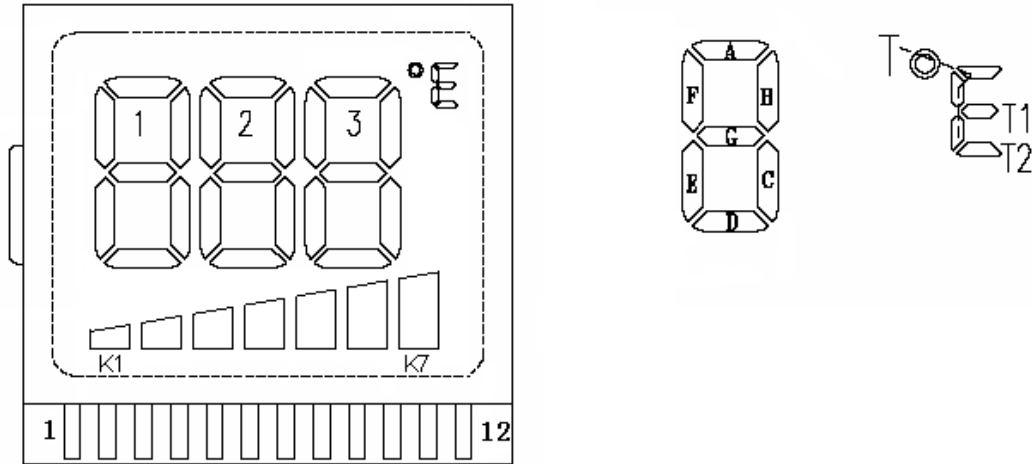
3) Support 12 PIN 5V LCD



Pin	1	2	3	4	5	6	7	8	9	10	11	12
COM4	K4	K1	1D	K2	2D	K3	3D					COM4
COM3	K5	1E	1C	2E	2C	3E	3C	T2			COM3	
COM2	K6	1G	1B	2G	2B	3G	3B	T1		COM2		
COM1	K7	1F	1A	2F	2A	3F	3A	T	COM1			

**Maximum Ratings**

Storage Temperature.....	-55°C to +150°C
Supply Voltage to Ground Potential (Input & V <sub>DD</sub> Only).....	-0.5V to +6.5V
Supply Voltage to Ground Potential (Outputs Only).....	-0.5V to +6.5V
DC Input Voltage.....	-0.5V to +6.5V
Input/Output Current.....	50mA
Input/Output Current (Pin VDD only).....	200mA
Power Dissipation.....	500mW

**Note:**

Stresses greater than those listed under MAXIMUM RATINGS may cause permanent damage to the device. This is a stress rating only and functional operation of the device at these or any other conditions above those indicated in the operational sections of this specification is not implied. Exposure to absolute maximum rating conditions for extended periods may affect reliability.

**Recommended operation conditions**

Sym	Parameter	Min	Typ	Max	Unit
V <sub>DD</sub>	Operating Voltage	4.0	-	V <sub>Z</sub>	V
T <sub>A</sub>	Operating temperature	-20	-	85	°C

**Electrical Characteristics** ( $V_{DD} = 4.0 \sim V_Z$ ,  $T_A = -20 \sim 85 \text{ }^\circ\text{C}$ , unless otherwise noted)

**DC Input Characteristics**

Symbol	Description	Test Conditions		Min	Type	Max	Unit	
		Step	Temp( $^\circ\text{C}$ )					
VNTC-ADC	Voltage of ADC	Pin:NTC1 $V_{DD}=4.5\text{V}$	Step 0	25	0.08	0.09	0.1	V
			Step 1	50	0.2375	0.2475	0.2575	
			Step 2	75	0.575	0.585	0.595	
			Step 3	90	0.8675	0.8775	0.8875	
			Step 4	100	1.089	1.099	1.109	
			Step 5	105	1.2163	1.2263	1.2363	
			Step 6	110	1.33	1.34	1.35	
			Step 7	115	1.45	1.46	1.47	
			Step 8	120	1.5875	1.5975	1.6075	
			Step 9	125	1.70	1.71	1.72	
			Step 10	130	1.81	1.82	1.83	
			Step 11	135	1.93	1.94	1.95	
			Step 12	140	2.05	2.06	2.07	
			Step 13	145	2.15	2.16	2.17	
			Step 14	150	2.25	2.26	2.27	
			Step 15	155	2.3525	2.35	2.3725	
			Step 16	160	2.43	2.44	2.45	
			Step 17	165	2.52	2.53	2.54	
			Step 18	170	2.60	2.61	2.62	
			Step 19	175	2.67	2.68	2.69	
			Step 20	180	2.72	2.73	2.74	
			Step 21	185	2.79	2.80	2.81	
			Step 22	190	2.845	2.855	2.865	
			Step 23	195	2.89	2.9	2.91	
			Step 24	200	2.94	2.95	2.96	
			Step 25	205	2.98	2.99	3.0	
			Step 26	210	3.0133	3.0233	3.0333	
			Step 27	215	3.0472	3.0572	3.0672	
			Step 28	220	3.08	3.09	3.10	
			Step 29	225	3.116	3.126	3.136	
			Step 30	230	3.138	3.148	3.158	
Step 31	234	3.16	3.17	3.18				
$I_{IH}$	Input high current	Pin:K1	$V_{IN} = V_{DD}, V_{CLK}=GND$	-	-	60	uA	
			$V_{IN} = V_{DD}, V_{CLK}=V_{DD}$	-	-	5		
		Pin: C/F, SEL2, SEL1	$V_{IN} = V_{DD}$	-	-	5	uA	
		Pin: K2	$V_{IN} = V_{DD}$	-	-	80	uA	
		Pin: CLK	$V_{IN} = V_{DD}$	-	-	1	$\mu\text{A}$	
		Pin:NTC1	$V_{IN} = V_{DD}$	-	-	100	nA	
$I_{IL}$	Input low current	Pin:K1	$V_{IN} = GND, V_{CLK} = -1\text{V}$	-	-	-5	$\mu\text{A}$	
			$V_{IN} = GND, V_{CLK} = 1\text{V}$	-	-	-60		
		Pin: C/F	$V_{IN} = GND$	-	-	-50	$\mu\text{A}$	
		Pin:K2 SEL1, SEL2	$V_{IN} = GND$	-	-	-5	$\mu\text{A}$	
		Pin: CLK	$V_{IN} = GND$	-	-	-5	$\mu\text{A}$	
			$V_{IN} = -0.35\text{V}$	-	-	-10	uA	
		Pin:NTC1	$V_{IN} = GND$	-	-	-100	nA	
Pin:NTC2	$V_{IN} = GND, \text{Output High impedance}$	-10	-	-100	nA			



### DC Output Electrical Characteristics

Symbol	Description	Test Conditions		Min	Type	Max	Unit	
I <sub>OH</sub>	Output High Current	Pin: GATE	V <sub>DD</sub> = 4.5V V <sub>OUT</sub> = 2.5V	-15	-	-	mA	
		Pin: BL1, BL2, BL3	V <sub>DD</sub> = 4.5V V <sub>OUT</sub> = 4.0V	-3.0	-	-		
I <sub>OL</sub>	Output Low Current	Pin: GATE	V <sub>DD</sub> = 4.5V V <sub>OUT</sub> = 0.5V	4.0	-	-	mA	
		Pin: BL	V <sub>DD</sub> = 4.5V V <sub>OUT</sub> = 0.5V	4.0	-	-		
V <sub>LCD</sub>	Output High Voltage	Pin: COM1, COM2, COM3, COM4, SEG1, SEG2, SEG3, SEG4, SEG,5, SEG6,	Level3	V <sub>DD</sub> = 4.5V	0.54V <sub>DD</sub>	0.6V <sub>DD</sub>	0.66V <sub>DD</sub>	
			Level2		0.36V <sub>DD</sub>	0.4V <sub>DD</sub>	0.44V <sub>DD</sub>	
			Level1		0.18V <sub>DD</sub>	0.2V <sub>DD</sub>	0.22V <sub>DD</sub>	

### Power Supply Characteristics

Symbol	Description	Test Conditions	Min	Type	Max	Unit
V <sub>POR</sub>	Voltage of POR	-	2	-	3	V
I <sub>DD</sub>	Current consumption	No loading, V <sub>DD</sub> = 4.5V	-	-	800	μA
V <sub>DD</sub>	Supply voltage	Control function normal	4.0	-	V <sub>Z</sub>	V
V <sub>Z</sub>	Voltage of Zener	I <sub>DD</sub> = 1mA ~ 20mA	4.5	5.0	5.5	V
TPO <sub>off</sub>	Power off timer	F <sub>CLK</sub> = 50Hz/60Hz	55	60	65	Minute

### Line Clock Synchronization Characteristics

Symbol	Description	Test Conditions		Min	Type	Max	Unit
V <sub>T-CLK</sub>	Input Threshold Voltage of CLK Pin	Level2		1.7	1.88	2.1	mV
		VTL_Level1	V <sub>DD</sub> = 4.5V VT_Level2 is high	-200	-250	-300	
		VTH_Level1	VT_Level2 is high	-100	-150	-200	
		VTL_Level1	V <sub>DD</sub> = 4.5V VT_Level2 is low	-125	-175	-225	
		VTH_Level1	VT_Level2 is low	-40	-90	-140	
		VTL_Level2	V <sub>DD</sub> = 4.5V VT_Level2 is high	105	145	185	
		VTL_Level2	VT_Level2 is high	210	250	290	
		VTL_Level2	V <sub>DD</sub> = 4.5V VT_Level2 is high	70	90	110	
VTL_Level2	VT_Level2 is high	145	185	225			
F <sub>CLK</sub>	Frequency of CLK	-		-	50/60	-	Hz

### GATE Pulse Characteristics

Symbol	Description	Test Conditions	Min	Type	Max	Unit
Tal_Gate	Width of Gate trigger pulse	T <sub>A</sub> = 25 °C, V <sub>DD</sub> = 4.5V	670	700	730	μs
		V <sub>DD</sub> = 4.0 ~ V <sub>Z</sub> T <sub>A</sub> = -20 ~ 85 °C	650	-	750	μs

**Application Circuit**

PT8A3362H for SOIC-24 and TSSOP-24

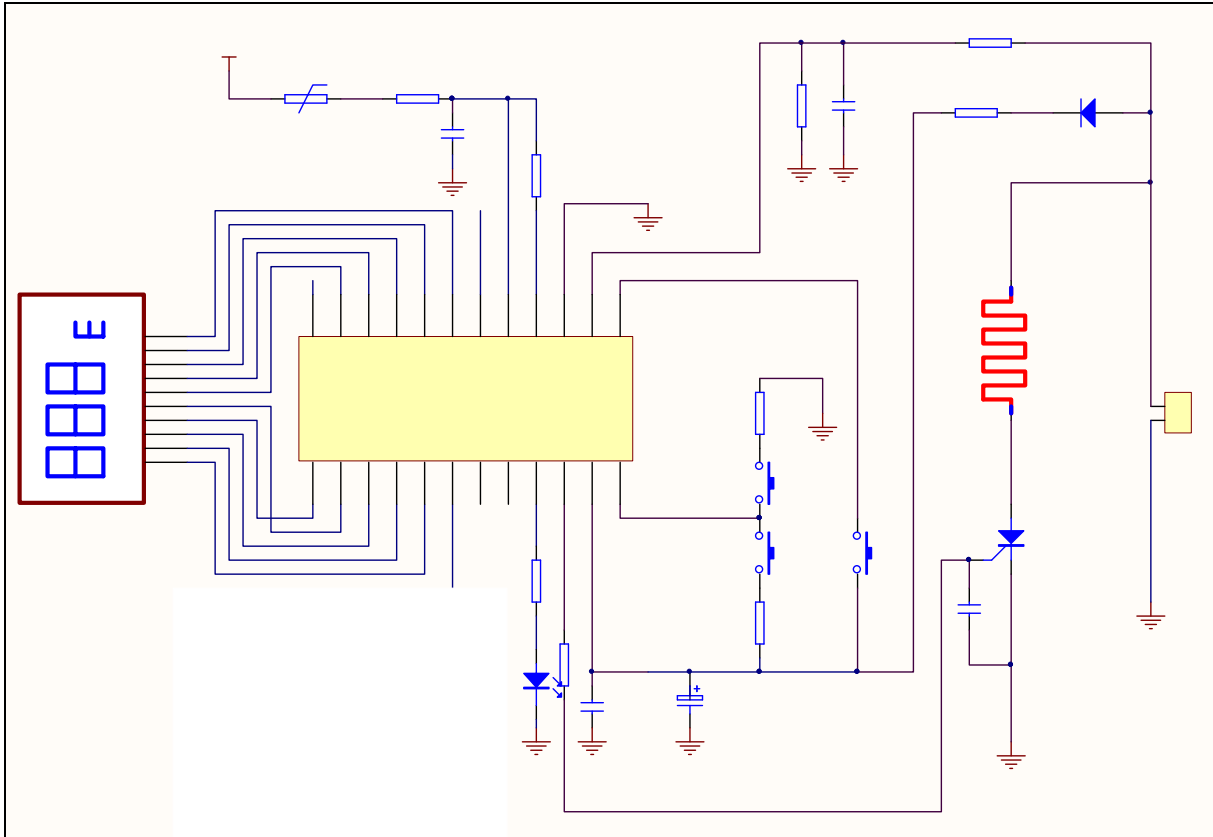

PT8A3362H for TQFN-24

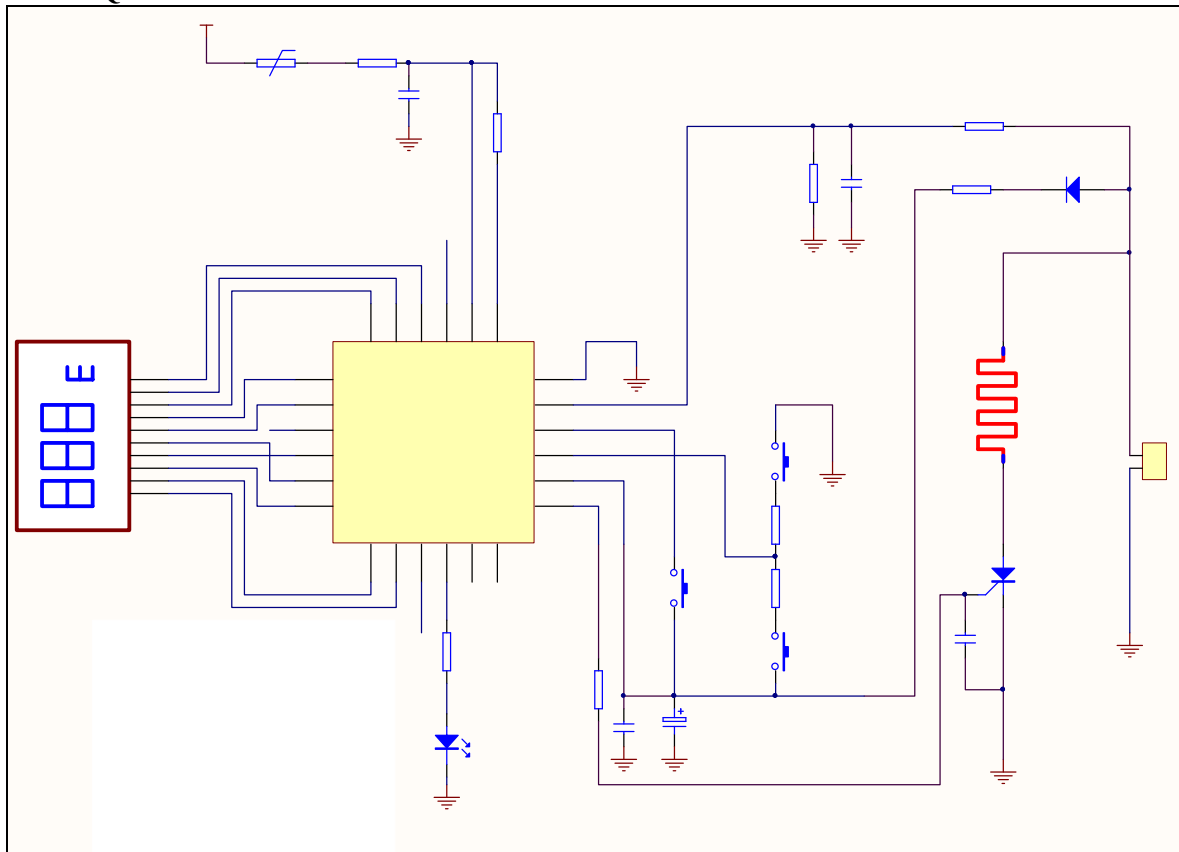

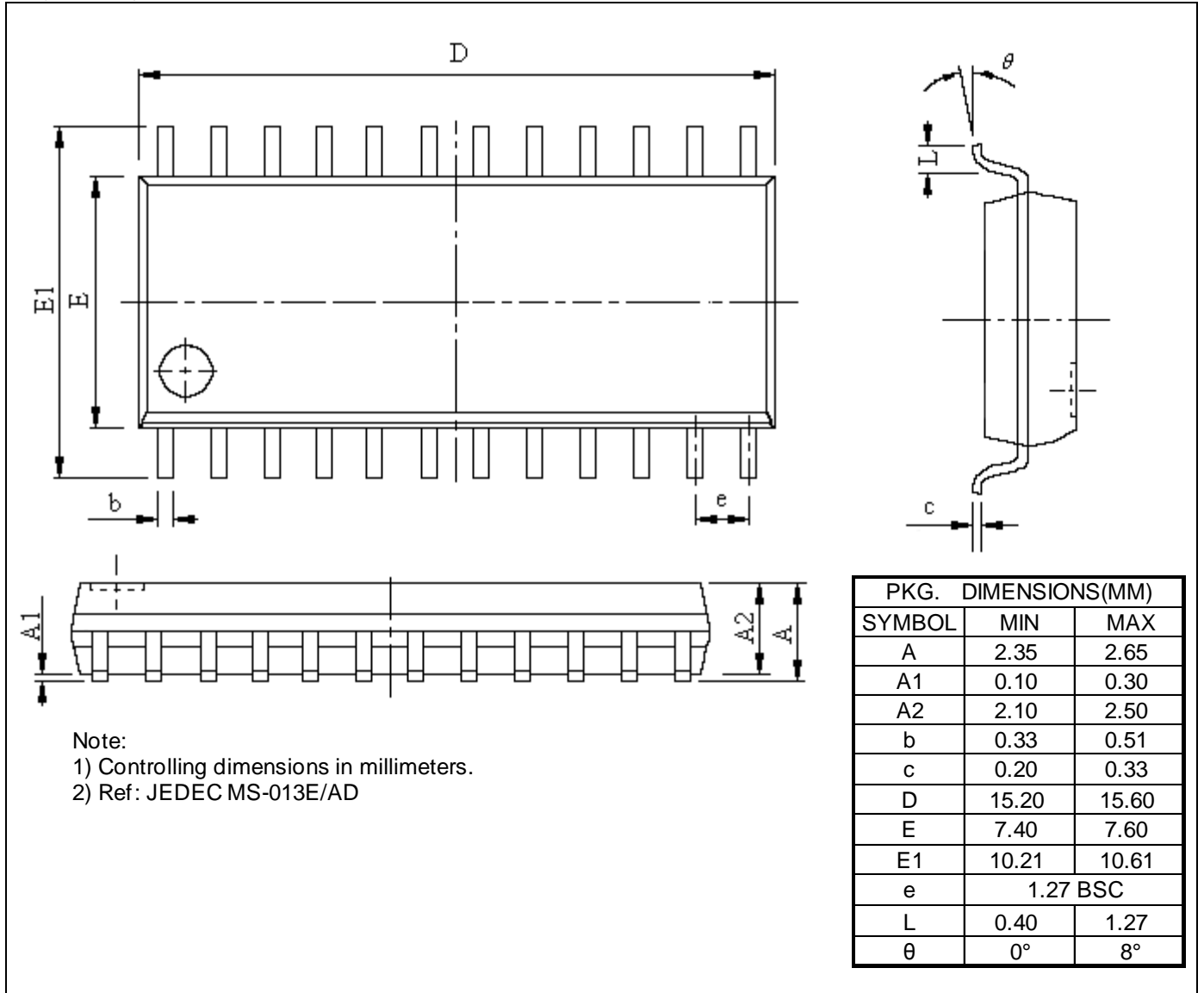
**Mechanical Information**
**SE (SOIC-24)**

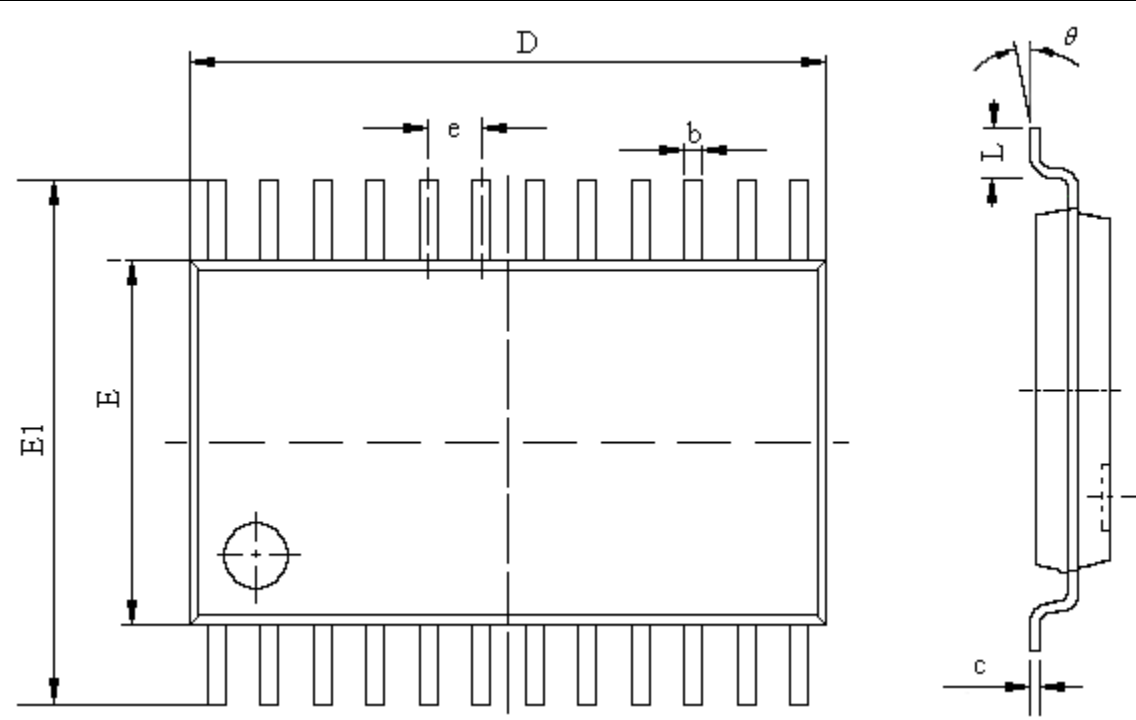
**LE (TSSOP-24)**

Note:  
 1)) Ref: JEDEC MO-153F/AD

PKG. DIMENSIONS(MM)		
SYMBOL	MIN	MAX
A		1.100
A1	0.020	0.150
A2	0.800	1.000
b	0.190	0.300
c	0.090	0.200
D	7.700	7.900
E	4.300	4.500
E1	6.250	6.550
e	0.65 BSC	
L	0.500	0.700
θ	1°	7°

ZDE (TQFN-24)

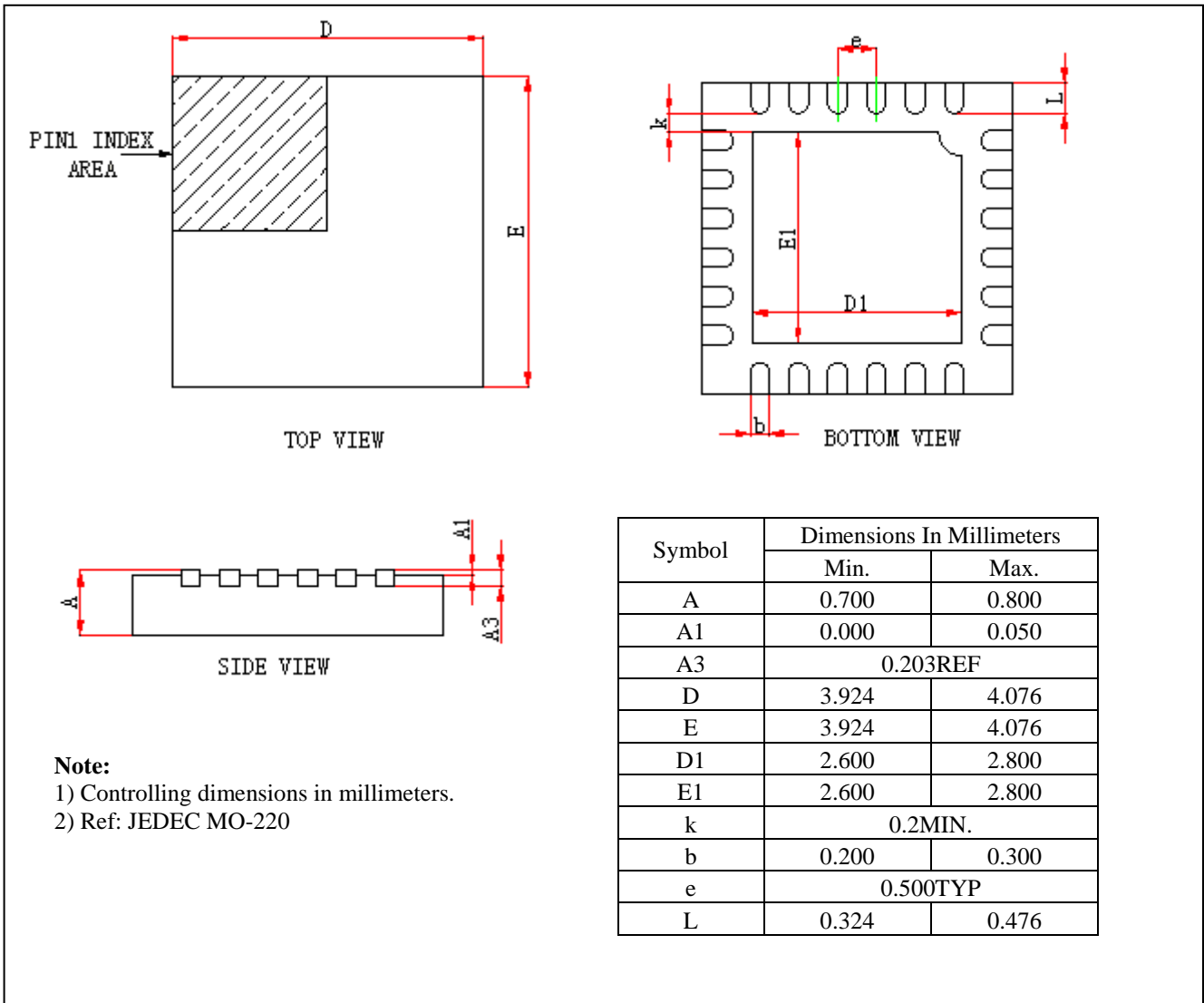

## Ordering Information

Part No.	Package Code	Package
PT8A3362HSE	S	Lead free 24-pin SOIC
PT8A3362HZDE*	ZD	Lead free and Green TQFN-24
PT8A3362HLE*	L	Lead free and Green TSSOP-24

**Note:**

- E = PPb-free or Pb-free & Green
- Adding X Suffix= Tape/Reel
- \*Contact Pericom for availability

Pericom Semiconductor Corporation • 1-800-435-2336 • [www.pericom.com](http://www.pericom.com)

Pericom reserves the right to make changes to its products or specifications at any time, without notice, in order to improve design or performance and to supply the best possible product. Pericom does not assume any responsibility for use of any circuitry described other than the circuitry embodied in Pericom product. The company makes no representations that circuitry described herein is free from patent infringement or other rights, of Pericom.