

Summary

The ZLPM8011 is a power management and control solution for satellite set-top boxes (STBs). Based on an efficient boost converter the ZLPM8011 provides the power supply and all the control signals required by a single-port satellite Low Noise Block (LNB). The ZLPM8011 includes an accurate 22kHz tone generator to provide DiSEqC™ control words or continuous tone for band switching control. To provide a reliable DiSEqC 2.0 solution, the IC includes a DiSEqC detector with unwanted signal rejection. Controlled by an I²C™ compatible interface or logic inputs and with the minimal external components, the ZLPM8011 provides a high-performing, efficient cost-effective solution.

Features

- High System Efficiency with Standby Mode
- Efficient Boost Converter and LDO Providing an Accurate Adjustable Power Supply for LNBs
- Provides a Protected Output of up to 550mA
 - Programmable Current Limit for System Flexibility
- Designed for Stability with Low-Power LNBs
- Provides Standard Voltage/Tone and DiSEqC Control Signals and Allows for Regional Variations, such as Japan
 - Internal Tone Generator for DiSEqC Control and Traditional Band Switching
 - Tone Maintains Shape Across all Load Conditions
- Internal Reliable Tone Detector for DiSEqC 2.0 Systems
- Controlled by I²C Interface or Independent Logic Control
- Built-in Multiple Diagnostics and Protection for IC and LNB Protection
- Minimal External Components for a Simple, Reliable, and Cost-Effective Solution
- **Totally Lead-Free & Fully RoHS Compliant (Notes 1 & 2)**
- **Halogen and Antimony Free. "Green" Device (Note 3)**

Notes:

1. No purposely added lead. Fully EU Directive 2002/95/EC (RoHS), 2011/65/EU (RoHS 2) & 2015/863/EU (RoHS 3) compliant.
2. See <https://www.diodes.com/quality/lead-free/> for more information about Diodes Incorporated's definitions of Halogen- and Antimony-free, "Green" and Lead-free.
3. Halogen- and Antimony-free "Green" products are defined as those which contain <900ppm bromine, <900ppm chlorine (<1500ppm total Br + Cl) and <1000ppm antimony compounds.

Applications

- Single Tuner Satellite Set-Top Boxes
 - High Current LNBs
 - Stability with Minimal Current LNBs
- Satellite PC Cards
- TVs with Integrated Satellite Tuners
- Hybrid Set-Top Boxes
- Suitable for Digital and Analog Satellite Systems

System Diagram

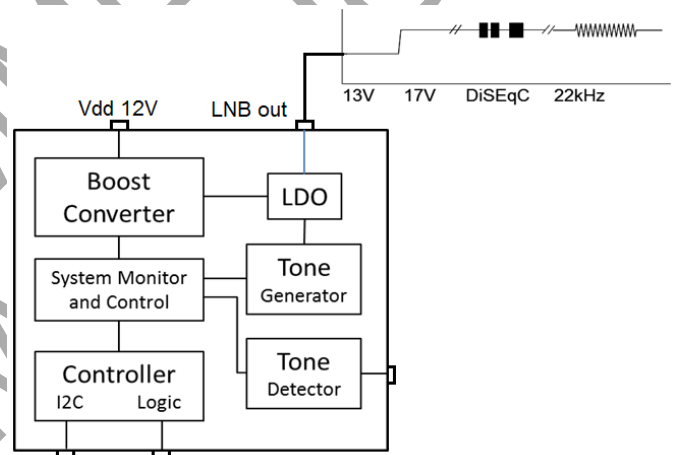

Product Description

The ZLPM8011 range provides a highly integrated, monolithic power management solution to meet the demands of satellite receiver Low Noise Blocks (LNBs). Its internal circuit blocks include an efficient boost converter, a low-noise LDO regulator, a tone generator and modulator, a tone detector, an I²C interface, and a logic controller. Most internal circuits are powered by an internal 3.3V regulator. A block diagram of the ZLPM8011 is shown in Figure 1.

Boost Converter and LNB Power Supply

The boost converter is used to generate a user trimable 13V/18V LNB supply using a standard STB power rail of 12V. The operating frequency of this switching converter is user controlled over the range 100kHz to 500kHz. The frequency is selected using an external capacitor wired to pin Fosc. The ZLPM8011 uses internal frequency compensation to maintain the loop stability of the switching regulator. This highly efficient converter includes over-voltage and overcurrent protection.

The boost converter supplies a low noise, low voltage drop linear regulator used for tone modulation and LNB isolation as part of STB power saving strategies. The LDOR also provides line open-circuit, line short circuit, soft start and current limiting systems. The boost converter/LDOR combination can supply a continuous LNB load of up to 550mA. The LNB supply V_{OUT} is programmable to allow the user to provide cable length compensation, specialist markets or to search for the voltage threshold level of the LNB.

The slew rate of V_{OUT} is programmable via capacitor CS. This capacitor is not required for stability reasons so it can be omitted.

The V_{OUT} output of the ZLPM8011 can be shut down either using the EN pin or the I²C Enable control bit (both must be low to disable the IC). In this state, the IC adopts a low current standby mode where all non-essential circuits are shut down.

22kHz / Tone Generation

The ZLPM8011 includes a 22kHz tone generator that can be used for LNB band switching or DiSEqC signaling. The tone frequency is user adjustable over the range 12kHz to 50kHz, set by a capacitor-resistor network connected to pin Tosc. Alternately, the RC network can be omitted and an external tone source can be applied via the Tosc pin instead. Tone on/off is controlled using the I²C or an independent logic pin Ten. When the tone generator is enabled the tone generated is modulated on the DC output of the LDOR via the pin V_{OUT}.

22kHz Detection

To support DiSEqC_2 return signaling, the ZLPM8011 includes an envelope detector for remote tone sources on the LNB line. The internal tone detector uses pin T_{DET}/T_{OUT} as its

input and provides an envelope output signal on pin T_{OUT} and in the I²C status register Tdet flag. To allow simple and reliable implementation the detector has been designed so that no external filtering is required whilst still providing a tone detector which rejects a wide range of unwanted signals.

Internal 3.3V Supply Availability

An internal 3.3V regulated supply is made available on the Creg pin to be utilized by other systems within the set-top box. Care should be taken that any load applied here should not exceed the limit quoted in the Specifications table and also that the total power dissipation limit of the ZLPM8011 is also observed.

System Control and Features Using I²C

To minimize STB microcontroller IO pin requirements, I²C is used as the primary control interface for the ZLPM8011, providing bi-directional information exchange containing a range of control signals, DiSEqC data and diagnostics. ZLPM8011 features controlled via the I²C bus include output enable, polarization (13V/18V selection), standard (13V/18V) or Japanese market (10.75V/14.75V) voltage control range selection, output voltage trim covering the range of 10.25V to 19.5V in 0.25V steps, V_{OUT} rise and fall time, tone on and current limit adjustment. Diagnostic information available includes over-temperature shutdown, over-current shutdown, output not-in regulation, short on V_{OUT} line, remote tone present and under-voltage lockout. The active I²C address of the IC is user selected from one of four possible addresses, allowing re-use of the I²C bus without address conflicts and hence further minimizing microcontroller IO requirements.

To allow for implementation of none I²C systems with the ZLPM8011, its I²C registers are set to default values on start up to allow its logic control pins to take priority.

System Control Using Logic

To further increase STB system design flexibility, key features of the ZLPM8011 can be controlled by direct inputs if required (i.e. without the use of the I²C bus). Direct control is available for Output Enable, Polarization (using default voltages of 13.25V/18.25V) and Tone Enable. For diagnostic purposes, the device includes a status indication output STS/INT pin, which can be used to initiate an interrupt on the host microcontroller to request attention or fault recovery. The direct logic control allows the ZLPM8011 to support low cost STB designs that do not require I²C bus features.

If the logic control pins are not required they should be connected to ground to avoid interference with I²C control.

Protection and Diagnostics

The ZLPM8011 provides a wide range of system protection and diagnostic features. These include overcurrent limit, line short circuit, line open circuit, overtemperature shutdown, and undervoltage alerts.

Current Limit

A user-defined low-power resistor (R_{ISET}) sets the maximum current limit for the LNB port, which is adjustable over the range 200mA to 550mA. This control provides two levels of overcurrent protection for the V_{OUT} port. If load current reaches the defined current limit, V_{OUT} is controlled (allowed to fall) to ensure that the current limit is not exceeded, the Out Of Regulation flag is set in the I²C status register and an internal timer is started. If the overload persists for longer than 65ms, the STS/INT pin is set low, the overcurrent flag in the I²C status register is set, and the port is permanently disabled. The port can re-enabled by restarting the (V_{IN}) power supply or by clearing then re-enabling the Enable logic control pin or I²C Enable control bit, once the fault condition has been resolved.

There are also two secondary current limits, which can be set by the I²C control registers. These can be used by the STB controlling firmware to reduce output current capability for certain applications (see I²C control register definition section).

Enable Sequence

Each time the ZLPM8011 is enabled, the IC performs a Shorted Line test by a sourcing a small current (10mA typical) to determine the V_{OUT} pin load resistance. If a short is detected, the Short on V_{OUT} line flag in the I²C status register is set. If no short-circuit is detected, the IC then initiates a soft-start sequence where the programmed V_{OUT} pin output voltage is applied using a controlled ramp-up time.

Line Check

At any time the IC is enabled, it can perform a line open circuit test. To activate this test, the N_{LNB} bit in the I²C control register should

be set. When set, the IC outputs a V_{OUT} target voltage of 22V, and the current limited to 5mA. If a load greater than 5mA is present (indicating an LNB is connected), the Output Not In Regulation flag remains clear. If no load is present (indicating an open line), the flag is set. Once the test establishes the load status, the No LNB control bit can be cleared and normal operation resumed.

Overtemperature Protection

To enhance system reliability, the ZLPM8011 includes an overtemperature shutdown circuit, which is set internally at a typical junction temperature of +150°C. Under this fault condition, the V_{OUT} output is disabled, the STS/INT pin is set low, and the overtemperature flag in the I²C status register is set. Once the die temperature falls back within acceptable operational limits, the V_{OUT} output can be re-enabled, and the STS/INT and I²C status register overtemperature flags are cleared by toggling either the EN control logic pin or I²C EN bit.

Power Up Sequence

Each time the ZLPM8011 is powered up, all internal functions of the IC are inhibited by an undervoltage lockout circuit until the voltage on the V_{IN} pin exceeds 8.5V. Once V_{IN} is above this level, the internal control registers of the ZLPM8011 are set to default levels. The STS/INT pin is set low to mark an undervoltage event and to request microcontroller attention. The V_{OUT} output will be in a disabled state regardless of the EN logic control input state. The STS/INT flag can be cleared by toggling any of the logic control pins (EN, VPOL, TEN), by reading the I²C status register, or by toggling the I²C EN control bit. The ZLPM8011 can be enabled by setting the EN logic control pin or I²C EN control bit high.

This power-up sequence ensures that the IC will not give spurious outputs during power-up.

Pin Assignment

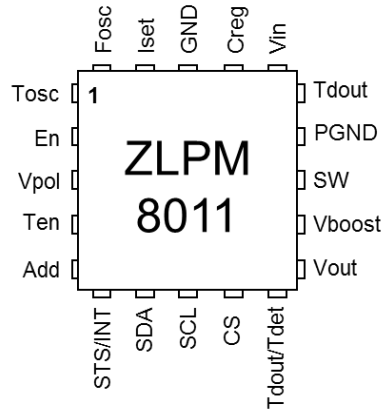

Pin Descriptions

Pin Number	Pin Name	Function
16	V _{IN}	Input Supply
18	GND	Signal Gnd
14	PGND	Power GND
13	SW	Internal Boost Converter MOSFET Drain
12	V _{BOOST}	Boost Converter Output Voltage Sense
11	V _{OUT}	Linear Regulator Output to LNB
9	CS	Capacitor Setting V _{OUT} Slew Rate
17	C _{REG}	Bypass Capacitor for Internal 3.3V Supply Regulator
20	F _{OSC}	Capacitor Setting Boost Converter Operating Frequency
19	I _{SET}	Current Limit Setting Resistor
4	T _{EN}	Enable Tone Modulation of V _{OUT} Output
10	T _{DET} /T _{OUT}	Tone Detect Input and Tone Signal Output for DiSEQC_2 Control Signals
15	T _{DOUT}	Tone Detect Envelope Output
1	T _{OSC}	R/C Network Setting Tone Oscillator Frequency or External Tone Input
3	V _{POL}	Selects 13.25V or 18.25V Output at V _{OUT}
6	STS/INT	Status pin (or Host Interrupt Signal Output). Used to indicate alert status or request the host microcontroller to read its status register.
2	EN	V _{OUT} Enable Pin
7	SDA	I2C Data Line
8	SCL	I2C Clock Line
5	ADD	Resistor Selecting Active I2C Address
PAD	PAD	Ground/Heatsink (Internally Connected to Gnd)

Functional Block Diagram

The functional diagram below in Figure 1 shows the internal architecture of the ZLPM8011 and the recommended applications circuit for a DiSEqC 2 system.

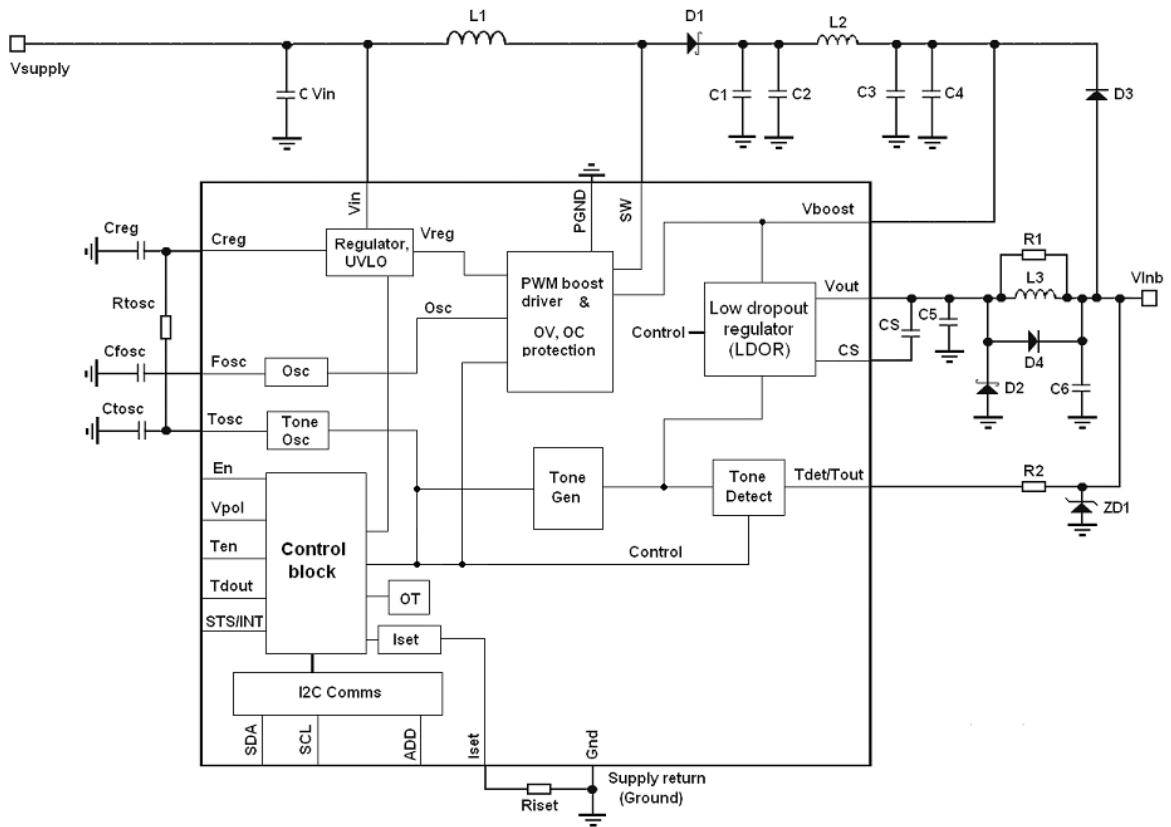

Figure. 1 ZLPM8011 Functional Diagram and Application Circuit for a DiSEqC 2 System

Component List			
Name	Value	Name	Value
R _{TOSC} (Note 5)	60k	C5	330nF
R _{ISET}	130k for 550mA see I _{SET} chart for other values	C6 (Note 4)	220nF
R1 (Note 4)	15Ω	C _{VIN}	1μF
R2 (Note 4)	1.8Ω	L1	6.8μH, 3A I _{SAT} , 60mΩ
C _{REG}	2.2μF Ceramic	L2	2.2μH, 1A I _{SAT} , 27mΩ
C _{FOSC}	47pF	L3 (Note 4)	220μH, 1A I _{SAT} , 100mΩ
C _{TOSC} (Note 5)	500pF	D1	B130L
CS	1nF	D2 (Note 4)	B130L
C1 (Note 6)	100nF Ceramic	D3	ES1A
C2	2.2μF	D4 (Note 4)	ES1A
C3 (Note 6)	100nF Ceramic	ZD1	3.0SMCJ20A
C4	22μF	—	—

- Notes:
4. Can be omitted for DiSEqC 1.x based systems.
 5. Can be omitted if an external tone source is used.
 6. Optional, can be omitted if C2 and C4 are ceramic capacitors.

Absolute Maximum Ratings (@T_A = +25°C, unless otherwise specified.)

Parameter	Rating	Unit
Supply Voltage (V _{IN})	-0.3 to +20	V
V _{OUT} , V _{BOOST} , CS, T _{DET} /T _{OUT}	-0.3 to +40	V
SW	-0.3 to +26	V
T _{OSC} , ADD, T _{DOUT} , I _{SET} , F _{OSC} , C _{REG}	-0.3 to +3.6	V
EN, V _{POL} , T _{EN} , SYS/INT, SDA, SDC	-0.3 to +5.5	V
Maximum V _{OUT} Load Current	1	A
Operating Temperature	-20 to +85	°C
Storage Temperature	-55 to +150	°C
Junction Temperature	+125	°C

Electrical Characteristics (@T_{AMB} = +25°C, Supply Voltage = 12V, I_{OUT} = 80mA, unless otherwise specified.)

Parameter	Conditions	Min	Typ	Max	Units
Supply Voltage Operating Range	(Note 7)	9	12	16	V
V _{IN} Current (Ena.)	I _{OUT} = 0mA, En = 3.3V, Boost inductor disconnected	—	3.5	—	mA
System Current (Ena.)	I _{OUT} = 0mA, En = 3.3V	—	6	—	mA
System Current (Disab.)	En = 0V, I _{CREG} = 0	—	600	1000	µA
UVL Threshold	Supply voltage rising	7.5	8.0	8.5	V
UVL Hysteresis	—	—	0.29	—	V
Switching Frequency					
Range	—	100	—	500	kHz
Frequency	C _{FOSC} = 47 pF	200	300	370	kHz
Power Switch (SW)					
On Resistance	I _{SW} = 300mA	—	300	—	mΩ
Current Limit	—	—	3	4	A
Leakage(Off)	En = 0V, V _{SW} = 20V	—	10	20	µA
V_{OUT}					
Output Voltage Low (Std)	Test Circuit Figure 1, I _{LOAD} = 300mA, V _{POL} = 0V	12.75	13.25	13.75	V
Output Voltage High (Std)	Test Circuit Figure 1, I _{LOAD} = 300mA, V _{POL} = 3.3V	17.75	18.25	18.75	V
Output range Low (Std)	—	12.75	—	14.5	V
Output range High (Std)	—	17.75	—	19.5	V
Output Voltage Low (LR)	Test Circuit Figure 1, I _{LOAD} = 300mA, V _{POL} = 0V	10.25	10.75	11.25	V
Output Voltage High (LR)	Test Circuit Figure 1, I _{LOAD} = 300mA, V _{POL} = 3.3V	14.25	14.75	15.25	V
Output range Low (LR)	—	10.25	—	12.0	V
Output range High (LR)	—	14.25	—	16.0	V

Notes: 7. V_{SUPPLY} – 1.5V should not exceed V_{OUT} under normal operating conditions.

Electrical Characteristics (cont.) (@ $T_{AMB} = +25^{\circ}C$, Supply Voltage = 12V, $I_{OUT} = 80mA$, unless otherwise specified.)

Parameter	Conditions	Min	Typ	Max	Units
V_{STEP}	Set by I^2C	—	0.25	—	V
Output Rise Time	From 13.25 to 18.25V, $C_S = 1nF$	—	500	—	μs
Output Fall Time	From 18.25 to 13.25V, Total $C_{OUT} < 1\mu F$	—	500	—	μs
Output Current	V_{OUT} active (Note 8)	0	—	550	mA
Output Ripple	Test Circuit , $I_{LOAD} = 550mA$, $V_{POL} = 3.3V$	—	10	—	mV
dV_{OUT} / dV_{IN}	—	—	0.5	5	mV/V
dV_{OUT} / dI	—	—	—	350	mV/A
dV_{OUT} / dT	—	—	50	—	ppm/ $^{\circ}C$
DISEqC Network Bypass Switch					
On-Resistance	Tone output enabled	—	1.5	—	Ω
Off-Resistance	Tone output disabled	—	>100	—	k Ω
Blocking Voltage	Tone output disabled, $I_{TDET/TOU} = 1mA$	—	+/-0.5	—	V
Startup					
Soft Start	Standard applications circuit	—	1.3	—	ms
Short Circuit Detect	(Note 8)	—	20	—	Ω
Tone Generator					
Tone Frequency	$C_{TOSC} = 500pF$, $R_{TOSC} = 60k$	20	22	24	kHz
Tone Amplitude pk-pk	V_{OUT} load capacitance < 500nF	400	600	800	mV
Tone Duty Cycle	—	45	50	55	%
Tone Rise And Fall Times	V_{OUT} load capacitance < 500nF $Trf = 0$	5.0	7.5	15.0	μs
Tone Rise And Fall Times	V_{OUT} load capacitance < 500nF $Trf = 1$	2.5	5.0	7.5	μs
Tone Start Up	Tone frequency = 22kHz	0	22	50	μs
Tone Shut Down	Tone frequency = 22kHz	0	22	50	μs
Tosc Input Frequency Rng.	3.3V logic signal, 50% duty cycle	12	—	50	kHz
Tone Detector					
Frequency Range	—	18	22	26	kHz
AC Thresh	22kHz square-wave input	100	140	200	mVp/p
Switching Delay	T_{DOUT} outputs	—	100	150	μs
Switching Delay (dTr/Tf)	400mVp/p 22kHz square-wave input	—	25	50	μs
Voltage High	$I_{T_{DOUT}} = -500\mu A$, Valid tone input present	3.0	3.3	3.6	V
Voltage Low	$I_{T_{DOUT}} = 500\mu A$, No tone input	0	0.05	0.5	V

Notes: 8. The V_{OUT} supply will not start-up if the load resistance is less than target stated (start-up only).

Electrical Characteristics (cont.) (@T_{AMB} = +25°C, Supply Voltage = 12V, I_{OUT} = 80mA, unless otherwise specified.)

Parameter	Conditions	Min	Typ	Max	Units
I²C Interface					
Input Voltage Low	—	—	—	0.94	V
Input Voltage High	—	2.4	—	5.5	V
Input Current (SCL / SDA)	Input voltage = 0 to +5.5V	-10	—	+10	μA
SDA Logic Out	I _{SDA} = 3mA	—	—	0.4	V
SCL Clock Frequency	—	—	—	400	kHz
Logic Control					
Enable Low	—	0	—	0.8	V
Enable High	—	2.4	—	5.5	V
V _{POL} Low	Selects 13.25V on V _{OUT}	0	—	0.8	V
V _{POL} High	Selects 18.25V on V _{OUT}	2.4	—	5.5	V
Tenable Inactive	—	0	—	0.8	V
Tenable Active	—	2.4	—	5.5	V
Input Current (All)	Input voltage = 0 to 5.5V	-10	—	+10	μA
Internal Regulator (C_{REG})					
Output Current Range	—	0	—	50	mA
Current Limit	V _{C_{REG}} = 0V	50	95	115	mA
Output Voltage	—	3.135	3.300	3.465	V
Protection and Diagnostics					
Thermal Shutdown	Junction temperature increasing	—	145	—	°C
Thermal Shutdown Hysteresis	—	—	15	—	°C
Overcurrent Shutdown	—	550	—	850	mA
Overcurrent Shut Down Delay Timer	—	—	65	—	ms
LNB Detect Current	V _{OUT} = 22V, Status Register N _{REG} flag set on No LNB	3	5	8	mA
I _{V_{OUT} Reverse (En.)}	Enabled, V _{OUT} = 21V, (Note 9)	—	100	—	mA
I _{V_{OUT} Reverse (Dis.)}	Disabled, V _{OUT} = 21V	—	600	2000	μA
V _{STS/INT} Low	I _{STS/INT} = 3mA	0	—	0.4	V
I _{STS/INT} Leakage	V _{STS/INT} = 5.5V	—	—	10	μA
ESD					
All Pins except I _{SET}	HBM test conditions	4	—	—	kV
I _{SET}	HBM test conditions	2	—	—	kV

Notes: 9. After 65ms, the output will be automatically disabled and the OCS and STS/INT flags will be set.

Typical Characteristics

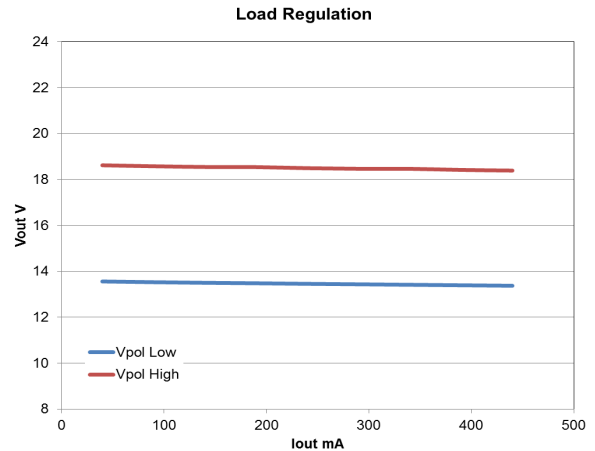
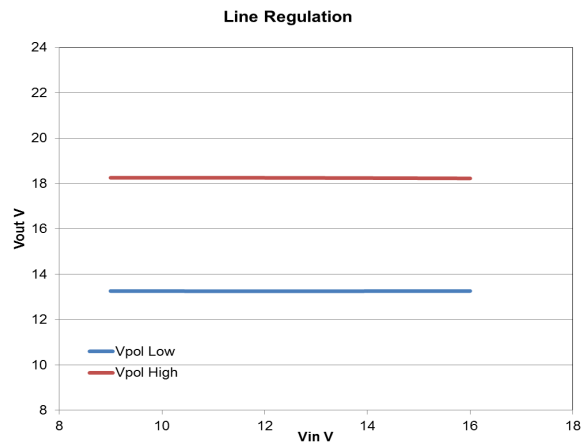
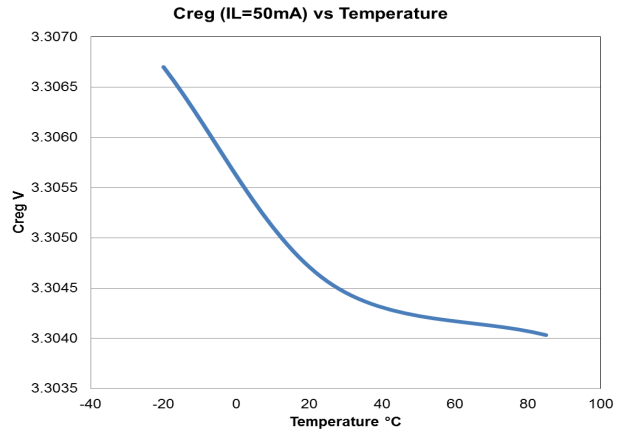
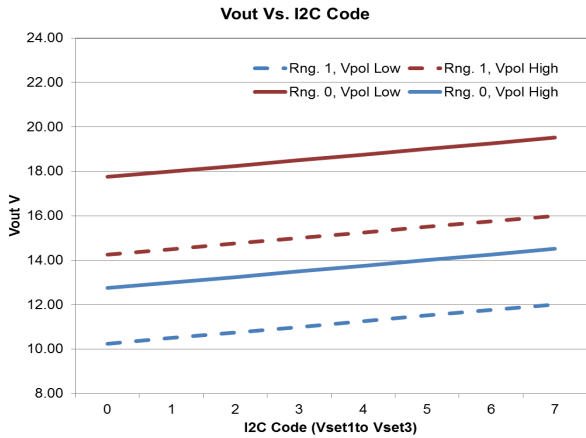
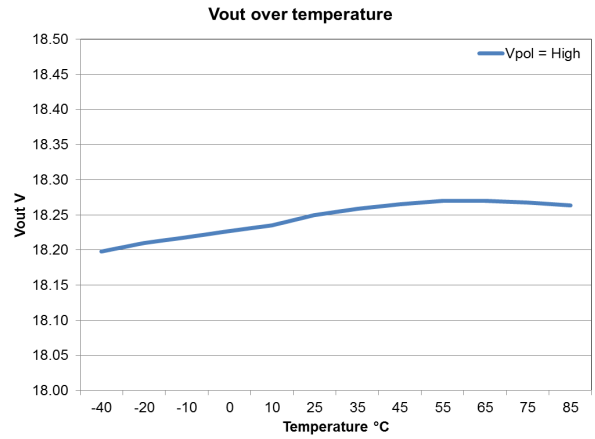
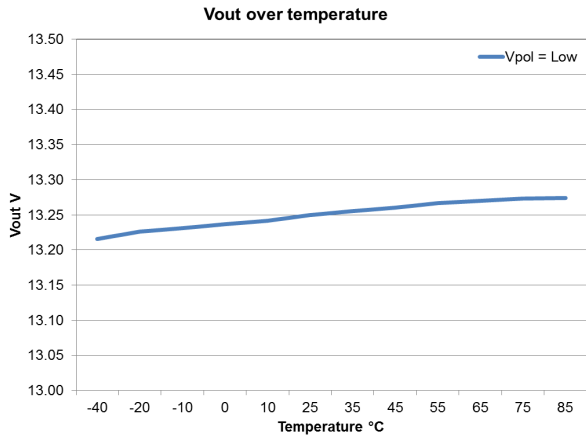

Typical Characteristics (cont.)

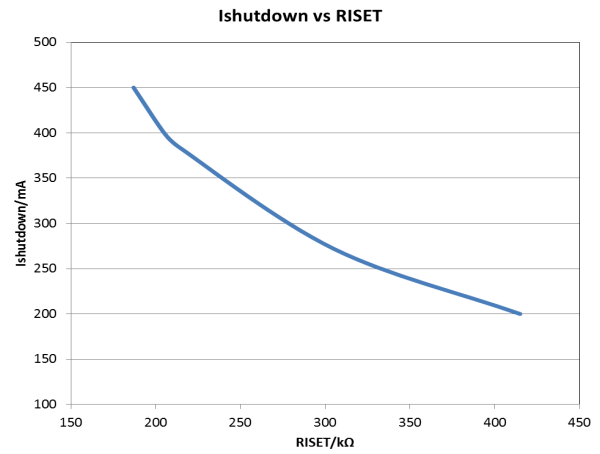
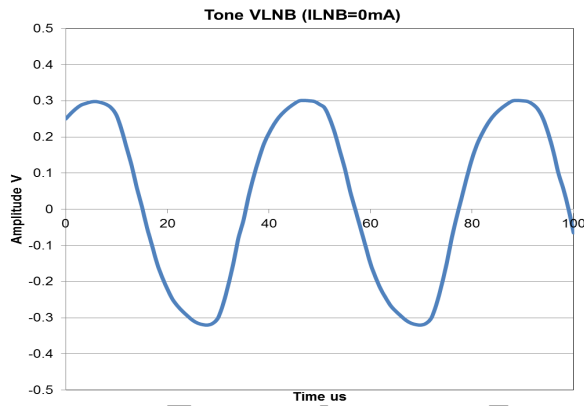
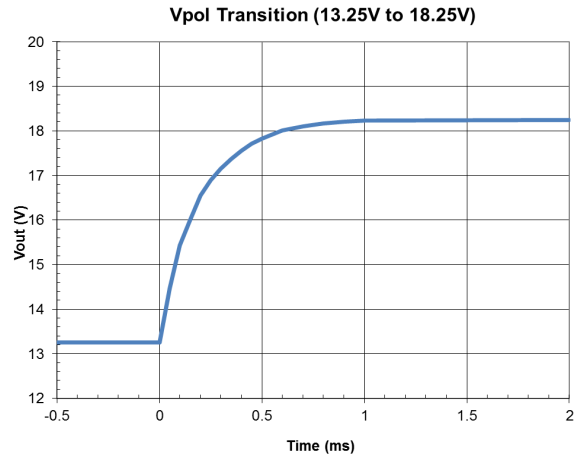
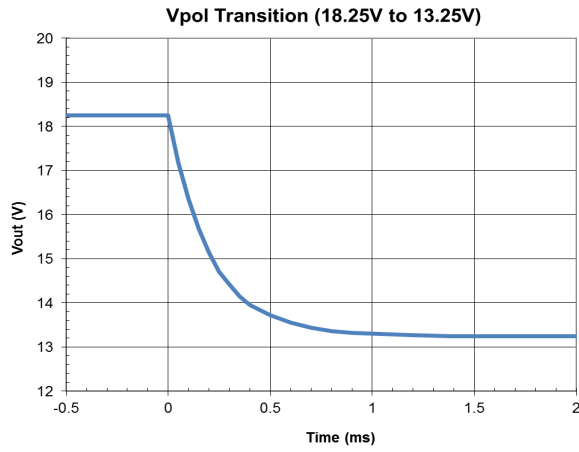

NOT FOR IMMEDIATE SIGNATURE

Application Information

Boost Converter

The ZLPM8011 uses internal frequency compensation to maintain the loop stability of the switching regulator. This compensation places some limits on the allowable inductor and load capacitor used in the switching converter. Follow the application circuit examples for typical values and limits.

The boost converter includes overcurrent and other protection circuits. Current limiting is performed cycle by cycle with a trip threshold set by the R_{ISET} resistor. To minimize external components the R_{ISET} has a dual purpose, it's also used to control the LDO current limit as described in the LDO section below. The default R_{ISET} value of 160k Ω gives a SW pin current limit of approximately 2.2A. Exceeding this current causes the present switching cycle to be terminated immediately, however the converter will continue to function.

The operating frequency of the boost converter is controlled by C_{fosc} . The default value of 47pF gives a typical frequency of 290kHz. By adjusting C_{FOSC} , this frequency can be varied if necessary over the range 100kHz to 500kHz (130pF to 27pF respectively). If this frequency is changed, it is possible that the values of related components of the boost generator (L1, L2, C2 and C4 in Fig1) will need adjustment.

Boost converter stability is not sensitive to low ESR output capacitor types. Hence, C1 and C2 can be merged as a single ceramic capacitor as can C3 and C4. Output ripple is dependent on the ESR of C4, hence the value of C4 can be smaller if a ceramic component is used. Dependent on output ripple requirements, inductor L2 can be omitted and C1, C2, C3, and C4 can merged as a single ceramic capacitor (consider values around 47 μ F).

Given the low resistance and fast switching speed of the boost converter switching transistor of the ZLPM8011, the boost circuit is capable of achieving a conversion efficiency of >96%. The boost inductor L1 and rectifier D1 are important in achieving this performance. Inductor L1 must be low resistance (preferably <60m Ω), have low core losses, and have an adequate saturation current (>2A). Avoid inductors with air-gaps close to the PCB since they can cause power loss and coupled noise into adjacent circuits. The rectifier D1 must have a low V_f and very fast reverse-recovery time. Be aware that even the very lowest V_f Schottky diodes can have considerable leakage, particularly when hot. Allow for diode leakage losses in power dissipation calculations. Mount D1 and C1 close to the SW and P_{gnd} pins of the ZLPM8011 to minimize radiated EMI. The ZLPM8011 evaluation board provides a good layout example. Contact Diodes for more details.

Low Dropout Regulator (LDOR)

The LDOR block of the ZLPM8011 performs a number of important tasks including output enable control, tone signal insertion, tone detection, soft-start control, polarisation change slew-rate control, LNB present detection, shorted line detection, externally applied overvoltage detection and output current limit control.

The LDOR is designed to operate into a capacitive load in the range of 200nF to 1 μ F, using a push-pull circuit to output tone signals without any DC load requirements. For DiSEQC 2 applications the LDOR is AC isolated from the LNB feed line by a standard LCR filter (L3, C6 and R1 in Figure 1.1), to allow remote tone insertion/replies. It is important that the resistance of L3 is kept low to minimise output voltage drop with load. The filter is bridged by the T_{DET}/T_{OUT} pin whenever the ZLPM8011 is outputting tone signals. Components D4 and R2 limit filter voltage drops and provide bridge protection in the event of output shorts or transients. Pin T_{DET}/T_{OUT} also serves as the tone detector input. For DiSEQC 1 applications, pin T_{DET}/T_{OUT} should be connected to V_{OUT} and the filter and the related protection components (R1, R2, L3, C6, D2, D4) can be omitted.

The LDOR of the ZLPM8011 is protected against externally applied overvoltage events. These can come from sources such as shorts to other STBs or nearby lightning discharges. If shorted to a STB that is set to give a higher output voltage, the ZLPM8011 will respond by setting its NREG status flag and also attempting to pull down the V_{out} pin to its target output voltage. If the external source is low impedance, then the ZLPM8011 will current limit at a safe level (100mA typical). Should the fault continue for more than 65ms, the STS/INT pin will be pulled low, the OCS status flag will be set, and the LDOR will be disabled, switching into a high impedance state. Once the fault is removed, the device can be re-enabled. Lightning surges are dealt with by the protection components ZD1, D2, D3, and D4.

The maximum (V_{OUT}) output current capability of the ZLPM8011 is user adjustable over the range 200mA to 550mA using R_{iset} . The graph $I_{Shutdown}$ vs R_{ISET} in the Typical Characteristics section shows the relationship between R_{iset} and maximum I_{load} . This control can be used to limit not only the maximum LNB load current but also the peak current taken from the system 12V power supply during start-up and polarisation voltage changes. An additional control of peak system current is the capacitor CS, which sets the slew-rate of V_{OUT} during polarisation voltage changes. The recommended value of CS (1nF) gives typical 10%-90% transition times of 500 μ s. The minimum recommended value for CS is 100pF. Note that the slew-rate control given by CS is not active when the tone generator of the ZLPM8011 is enabled.

Application Information (cont.)

Tone Generator

The ZLPM8011 includes a versatile tone generator/modulator that can be used for LNB band switching or DiSEqC signalling. An internal tone oscillator or an external (logic) signal can be used as the tone source. Tone On/Off (V_{OUT} modulation) is controlled using the I²C bus or the ten logic pin. Possible tone generator implementations include:

- 1) Internal tone oscillator switched/modulated using I²C or Ten pin control.
- 2) External tone input (to the TOSC pin) switched/modulated using I²C or Ten pin control.
- 3) External tone burst input pre-modulated with Band/ DiSEqC control (with Ten logic pin wired permanently high). Please note that tone burst inputs must always end logic low in this mode.

ZLPM8011 internal logic ensures that above modes (1) and (2) always gives complete cycles of tone, regardless of modulation timing. This logic also generates envelope information for mode (3). The tone signal processing ensures that the DC voltage level on V_{OUT} is not affected by tone modulation.

To use the internal tone oscillator, a resistor capacitor network (as shown in Fig.1) should be connected to pin TOSC. The following table shows the recommended component values required for commonly used oscillator output frequencies.

Output Tone Frequency	R_TOSC	C_TOSC
(kHz)	(k Ω)	(pF)
22	60	500
43	56	270

$$\text{Tone Frequency} = (660000 / (R \times C)) \text{ kHz (Approx.)}$$

(R in k Ω , C in pF)

To add tone via an external source the components R_Tosc and C_Tosc can be omitted.

Regardless of the signal waveform applied to the Fosc pin of the ZLPM8011, the IC will always generate a square-wave tone output. Edge speeds can be user selected using the I²C Trf control bit. When the Trf bit is set to 0 (default), tone signal rise and fall times are 10 μ s typical and when Trf is set to 1, the rise and fall times are 5 μ s typical.

I²C Interface

For generic information about the electrical specifications and protocols of an I²C interface, please consult the NXP document UM10204 I²C-bus specification and user manual Rev.03 – 19th June 2007.

The I²C interface of the ZLPM8011 provides access to a single status register and two control registers. All registers are 8 bits in length and use the same I²C bus address. The status register can be read by submitting an I²C read command using the bus address of the ZLPM8011. On receipt of this command, the ZLPM8011 will acknowledge the request and then output the status byte, sending the MSB first. The bus master can re-read the status byte indefinitely if it acknowledges each byte received. A read sequence can be finished either by sending a “not-acknowledge” signal at the end of a byte read or by sending a Stop command. The I²C bus master cannot write to the status register.

The control registers can be written by submitting an I²C write command using the bus address of the ZLPM8011. On receipt of this command, the ZLPM8011 will acknowledge the request. Following this acknowledge signal, the I²C bus master will then be able to write to the control registers, one byte at a time, under the control of a register address counter. The first data byte sent will be copied into Control Register 1 and the second into Control Register 2. Each byte received by the ZLPM8011 will be acknowledged. If further bytes are sent by the I²C bus master, the register address counter will wrap around so that the next byte will be copied into Control Register 1 and the next into Control register 2 etc. A write sequence is terminated by the I²C bus master sending a Stop command. It is permissible to write just one byte, which will be copied into Control Register 1. The I²C bus master cannot read the contents of the control registers.

Application Information (cont.)

I²C Addressing

To avoid system conflicts the ZLPM8011 provides a choice of four I²C addresses. To help minimise the pin count the ZLPM8011 uses a single pin to set the address. This is achieved by adding a single resistor connected between the Add pin and Gnd. The table below shows the address to resistor value relationship. A resistor tolerance of $\pm 5\%$ is sufficient. The address bit marked "x" denotes the I²C R/W bit, which should be low for Write and high for Read.

	Address	Resistor value
Address 1	0001000x	Zero Ω (Gnd)
Address 2	0001001x	68k
Address 3	0001010x	360k
Address 4	0001011x	Open Circuit

I²C™ Registers

Status Register

Bit	Name	Description	STS/INT	Flag
0	OTS	Overtemperature Shutdown	Yes	Cleared by Status read after cooling
1	OCS	Overcurrent Shutdown	Yes	Cleared when Enable is reset
2	NREG	Output not in Regulation	No	Cleared Automatically
3	SLNB	Short on V _{OUT} Line (Active Low)	No	Cleared Automatically
4	T _{DET}	Return Tone Signal Currently Detected	Selectable	Set and cleared automatically
5	UVL	Undervoltage Lock	Yes	Set when Vin enters normal working range
6	—	Not used	—	—
7	—	Not used	—	—

Overtemperature Shut Down (OTS)

If the junction temperature of the ZLPM8011 exceeds +150°C, the over temperature register and STS/INT flags are set. Also the boost converter and the V_{OUT} output are disabled, regardless of the state of the En controls. The device can only be re-enabled once the junction temperature has fallen to a safe operating level. The OTS flag can be cleared by a status register read. The STS/INT flag can be cleared by reading the status register, by changing the I²C EN control bit or by changing any of the logic control pins (EN, V_{POL}, TEN).

Overcurrent Shut Down (OCS)

If the V_{OUT} output of the ZLPM8011 is overloaded, the device will initially allow V_{OUT} to fall to limit the output current to the level set by R_{ISET}. The fault is indicated by setting the NREG flag, but an interrupt is not given at this time to avoid flagging spurious current spikes such as transients from polarization changes. However, after 65ms the overcurrent is determined as a real fault and the

OCS register and the STS/INT flags are set. The overcurrent flag can be reset using a status register read operation. The STS/INT flag can be cleared by reading the status register, by changing the I²C EN control bit or by changing any of the logic control pins (EN, V_{POL}, TEN). The ZLPM8011 can be restarted by clearing then re-enabling the active enable control input (I²C or logic). If the overcurrent fault still persists, the process will be repeated.

The OCS flag can also be set if an external voltage source is used to drive the V_{OUT} pin to greater than its target voltage. (This can happen if two STB LNB outputs are accidentally connected together.) The ZLPM8011 is designed to withstand this fault and to limit the resulting input current to 100mA typical. To avoid the risk of excessive power dissipation in a sustained fault condition of this type, the OCS control circuit will trigger after 65ms, shutting down the V_{OUT} output and setting the STS/INT pin low. The ZLPM8011 can be restarted normally once the fault is rectified.

Output Not in Regulation (NREG)

The output not in regulation register flag is set when the V_{OUT} output is pulled away from its target voltage, usually by a faulty load. This flag automatically clears when the fault is removed. Its primary use is in detecting an open circuit LNB line (see the NLNB control bit). The NREG bit may be set transiently during start-up or polarisation change events if the V_{OUT} load includes a large capacitor. An NREG event does not set the STS/INT flag.

Application Information (cont.)

Short on V_{OUT} Line (SLNB)

Whenever the V_{OUT} output is enabled, the ZLPM8011 executes a shorted-line test. During this test, the device outputs a current of 10mA typical and monitors the output voltage. The ZLPM8011 will only enable its full output current capability when V_{OUT} exceeds 200mV during this test. The short on V_{OUT} line register flag is active (low) for the duration of the test and is automatically cleared (high) if and when V_{OUT} rises above 200mV. The S_{LNB} test has no effect on the STS/INT flag.

Return Tone Signal Currently Detected (T_{DET})

The T_{DET} register flag is set whenever a valid tone signal is currently detected on the T_{DET}/T_{OUT} pin. This flag responds both to internally and externally generated tone signals. This flag is not latched and so will only be set when a tone is currently present.

If required, tone detection events can be used to signal a controller alert, by setting the STS/INT pin low. This capability is activated using the Tint control bit. With the Tint bit set to 0 (default setting), tone detection events have no effect on the STS/INT pin. However if the Tint bit is set to 1, then the STS/INT pin will be set low whenever the T_{DET} flag changes state (i.e. whenever it changes from 0 to 1 or from 1 to 0). The STS/INT flag can be cleared by reading the status register, by toggling the I²C EN control bit or by toggling any of the logic control pins (EN, V_{POL} , TEN).

Undervoltage Lock (UVL)

The undervoltage lockout circuit of the ZLPM8011 inhibits all device operation when voltage on V_{IN} is below the UVL threshold. Once V_{IN} returns to its normal operating range, the UVL register and STS/INT flags are set to signal the power-up/brown-out event. Also, all I²C control registers are set to default states and V_{OUT} is disabled regardless of the state of the En input. The UVL register flag can be cleared by a status register read. The STS/INT flag can be cleared by changing any of the logic control pins (EN, V_{POL} , TEN), by reading the I²C status register, or by changing the I²C EN control bit.

Control Register 1

Bit	Name	POR Value	Bit Setting	Description
0	V_{SET} 1	0	See V_{OUT} control table	3 bits are used for LNB supply voltage trimming, adjusting the output voltage in 0.25V increments
1	V_{SET} 2	1	See V_{OUT} control table	
2	V_{SET} 3	0	See V_{OUT} control table	
3	POL Sel	0	0 = low V_{OUT} range 1 = high V_{OUT} range	Single bit selection of the polarization channel
4	V_{POL} Rng.	0	0 = standard V_{POL} range 1 = Japan V_{POL}	Sets the LNB to the Standard or Japanese voltage range
5	Tint	0	0 = no tone interrupt 1 = tone interrupt	Selects interrupt on tone level change
6	Tone	0	0 = tone output disabled 1 = tone output enabled	Tone output on or off
7	Enable	0	0 = V_{OUT} disabled 1 = V_{OUT} enabled	Enable/Disable the V_{OUT} Output

Control Register 2

Bit	Name	POR Value	Bit Setting	Description
0	I_{SET} 1	0	See I_{SET} table	Current limit bit 1
1	I_{SET} 2	0	See I_{SET} table	Current limit bit 2
2	N_{LNB}	0	0 = LNB test disable 1 = Test for LNB presence	Activates the No LNB test. The Status N_{REG} bit set if no LNB is found.
3	Trf	0	0 = 10 μ s 1 = 5 μ s	Sets the rise and fall time of the tone.
4	—	0	Set to 0	Not used
5	—	0	Set to 0	Not used
6	—	0	Set to 0	Not used
7	—	0	Set to 0	Not used

Application Information (cont.)

V_{OUT} Control

To simplify the I²C commands the ZLPM8011 has 5 bits to select and control the output. The LNB polarization select (Pol Sel) bit is used to select between horizontal and vertical or left and right polarisation to eliminate difficult calculations when compensating for line lengths. If necessary the output voltage can be trimmed in increments of ±0.25V steps from the centre voltages of 13.25V/10.75V and 18.25V/14.75V. Once the adjustment has been decided the Vset bits can remain constant for each state. This makes it possible to switch between the compensated V_{OUT} voltages by using pol select alone. To provide greater market flexibility the ZLPM8011 has a regional bit which sets the V_{OUT} centres at 10.75V and 14.75V instead of 13.25V and 18.25V.

		Enable	V _{POL} Rng.	Pol Sel	V _{SET3}	V _{SET2}	V _{SET1}	V _{OUT} Adj	LNB V
LNB Range Standard	Vertical	1	0	0	0	0	0	-0.50	12.75
		1	0	0	0	0	1	-0.25	13.00
		1	0	0	0	1	0	0.00	13.25*
		1	0	0	0	1	1	0.25	13.50
		1	0	0	1	0	0	0.50	13.75
		1	0	0	1	0	1	0.75	14.00
		1	0	0	1	1	0	1.00	14.25
		1	0	0	1	1	1	1.25	14.50
	Horizontal	1	0	1	0	0	0	-0.50	17.75
		1	0	1	0	0	1	-0.25	18.00
		1	0	1	0	1	0	0.00	18.25*
		1	0	1	0	1	1	0.25	18.50
		1	0	1	1	0	0	0.50	18.75
		1	0	1	1	0	1	0.75	19.00
		1	0	1	1	1	0	1.00	19.25
		1	0	1	1	1	1	1.25	19.50
LNB Range Low	Vertical	1	1	0	0	0	0	-0.50	10.25
		1	1	0	0	0	1	-0.25	10.50
		1	1	0	0	1	0	0.00	10.75
		1	1	0	0	1	1	0.25	11.00
		1	1	0	1	0	0	0.50	11.25
		1	1	0	1	0	1	0.75	11.50
		1	1	0	1	1	0	1.00	11.75
		1	1	0	1	1	1	1.25	12.00
	Horizontal	1	1	1	0	0	0	-0.50	14.25
		1	1	1	0	0	1	-0.25	14.50
		1	1	1	0	1	0	0.00	14.75
		1	1	1	0	1	1	0.25	15.00
		1	1	1	1	0	0	0.50	15.25
		1	1	1	1	0	1	0.75	15.50
		1	1	1	1	1	0	1.00	15.75
		1	1	1	1	1	1	1.25	16.00

Note: * Default values selected when using V_{POL} logic pin, 13.25V is the default after a Power On Reset.

Application Information (cont.)

Tone Interrupt (Tint)

When set, this control bit triggers Sts/Int interrupts whenever the Status Tdet flag changes state. The ZLPM8011 can detect tone signals externally applied to the V_{OUT} output (usually DiSEqC signals). Detection is indicated by setting the Status register flag T_{DET} . Externally generated DiSEqC burst timing can be followed more accurately using interrupts rather than Status polling.

Tone On (Tone)

When set, this control bit selects the addition of a low level tone signal to the V_{OUT} output of the ZLPM8011. Refer to the Applications section of this datasheet for advice on tone source and frequency selection.

Enable

This control bit activates the boost converter and LDO stages of the ZLPM8011 to provide the pre-determined output voltage at V_{OUT} . If while the Enable control is set, the ZLPM8011 gets internally disabled by an OTS or OCS event, then the control bit must be cleared before the device can be re-enabled.

I²C Current Limit (I_{SET1}, I_{SET2})

In addition to the maximum current setting via Iset, the ZLPM8011 allows an additional three current limit steps by using I²C control. This allows STB firmware to set-up the LNB power supply to match the intended application. The three extra steps are 40%, 50% and 67% of I_{SET}. The truth table below shows the I²C register set-up and an example of the maximum output current based on an Iset of 550mA.

I ² C Register		LNB Supply Current	
I _{SET2} (Bit 1)	I _{SET1} (Bit 0)	% of I _{SET}	I _{OUT} Max (mA)
0	0	100%	550
0	1	67%	368
1	0	50%	275
1	1	40%	220

No LNB Present (NLNB)

Set this control bit to select the No LNB Detection mode. In this mode, the ZLPM8011 generates a V_{OUT} of 22V with a pre-set current limit of 5mA nominal. If a load of less than 5mA is connected to V_{OUT} , its output remains at 22V, and the ZLPM8011 sets the Nreg flag of the Status register, indicating that no LNB is present. If an LNB load of greater than 5mA is connected to the V_{OUT} , current limiting occurs, and the voltage on V_{OUT} will fall. This is detected by the ZLPM8011 which will clear the N_{REG} flag of the Status register. De-select the LNB Detection mode for normal operation of the ZLPM8011.

Tone Risetime (Trf)

The bit controls the rise and fall times of the any tone added to its V_{out} output by the ZLPM8011. When clear, rise and fall times of 10 μ s nominal are generated. When set, rise and fall times of 5 μ s nominal are generated. Generally, 10 μ s is used for standard (22kHz) tone signals and 5 μ s for Japanese (higher frequency tones).

System Design Considerations - Device Mounting

Under normal STB operation, the boost converter and regulator functions of the ZLPM8011 can result in an internal power dissipation of 0.5W to 2W dependant on the STB load. To help remove the heat generated by this power dissipation the device must be provided with adequate heatsinking. Most of the heat dissipated in the components of the IC flows through the die, die attach and finally the package frame, exiting through the metal tab in the base of the device. It is vital that this tab is soldered to a PCB designed to give a low thermal resistance. This can be achieved by using the following recommendations:

- 1) Use a double-sided multi-(4)layer PCB with 1 ounce copper (35 μ m) or thicker on top/bottom sides. The inner layers and back-side of the PCB should have substantial unbroken areas of copper directly underneath the ZLPM8011.
- 2) There should be at least 4, but preferably 9 or more thermal vias in the PCB between the device tab and the back of the board. These should be plated with 0.5 ounce copper (18 μ m) or thicker.
- 3) The PCB housing must be designed so that the back of the PCB adequate air-flow, particularly near the ZLPM8011 there components mounted on the PCB that may dissipate high power levels should not be placed close to the ZLPM8011.

The J-C (junction-to-case) thermal resistance of the ZLPM8011 is typically 5.5°C/W. When designing a PCB for use with the ZLPM8011, the user must take into account the likely power dissipation, the recommended maximum die temperature, the maximum ambient temperature and the combined thermal resistance of the device and its PCB mounting arrangement.

Ordering Information

Part Number	Package	Reel Size	Tape Width	Quantity per Reel
ZLPM8011JB20TC	U-QFN4040-20	13" (330mm)	12mm	3000

Package Outline Dimensions (All dimensions in mm.)

Please see <http://www.diodes.com/package-outlines.html> for the latest version.

U-QFN4040-20

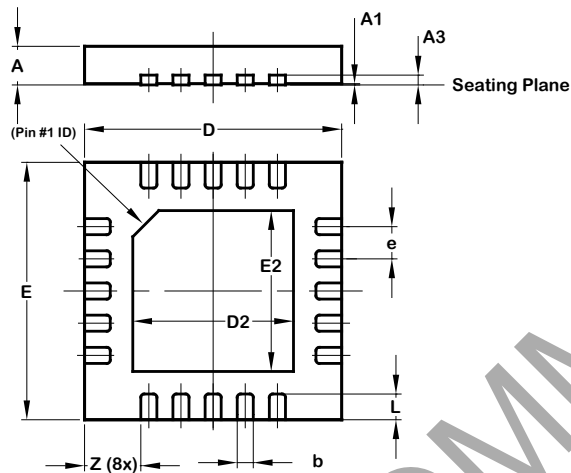

U-QFN4040-20			
Dim	Min	Max	Typ
A	0.55	0.65	0.60
A1	0	0.05	0.02
A3	-	-	0.15
b	0.20	0.30	0.25
D	3.95	4.05	4.00
D2	2.40	2.60	2.50
E	3.95	4.05	4.00
E2	2.40	2.60	2.50
e	0.50 BSC		
L	0.35	0.45	0.40
Z	-	-	0.875
All Dimensions in mm			

Suggested Pad Layout

Please see <http://www.diodes.com/package-outlines.html> for the latest version.

U-QFN4040-20

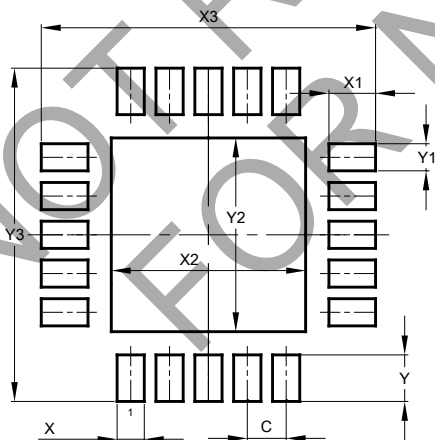

Dimensions	Value (in mm)
C	0.500
X	0.350
X1	0.600
X2	2.500
X3	4.300
Y	0.600
Y1	0.350
Y2	2.500
Y3	4.300

IMPORTANT NOTICE

DIODES INCORPORATED MAKES NO WARRANTY OF ANY KIND, EXPRESS OR IMPLIED, WITH REGARDS TO THIS DOCUMENT, INCLUDING, BUT NOT LIMITED TO, THE IMPLIED WARRANTIES OF MERCHANTABILITY AND FITNESS FOR A PARTICULAR PURPOSE (AND THEIR EQUIVALENTS UNDER THE LAWS OF ANY JURISDICTION).

Diodes Incorporated and its subsidiaries reserve the right to make modifications, enhancements, improvements, corrections or other changes without further notice to this document and any product described herein. Diodes Incorporated does not assume any liability arising out of the application or use of this document or any product described herein; neither does Diodes Incorporated convey any license under its patent or trademark rights, nor the rights of others. Any Customer or user of this document or products described herein in such applications shall assume all risks of such use and will agree to hold Diodes Incorporated and all the companies whose products are represented on Diodes Incorporated website, harmless against all damages.

Diodes Incorporated does not warrant or accept any liability whatsoever in respect of any products purchased through unauthorized sales channel. Should Customers purchase or use Diodes Incorporated products for any unintended or unauthorized application, Customers shall indemnify and hold Diodes Incorporated and its representatives harmless against all claims, damages, expenses, and attorney fees arising out of, directly or indirectly, any claim of personal injury or death associated with such unintended or unauthorized application.

Products described herein may be covered by one or more United States, international or foreign patents pending. Product names and markings noted herein may also be covered by one or more United States, international or foreign trademarks.

This document is written in English but may be translated into multiple languages for reference. Only the English version of this document is the final and determinative format released by Diodes Incorporated.

LIFE SUPPORT

Diodes Incorporated products are specifically not authorized for use as critical components in life support devices or systems without the express written approval of the Chief Executive Officer of Diodes Incorporated. As used herein:

- A. Life support devices or systems are devices or systems which:
1. are intended to implant into the body, or
 2. support or sustain life and whose failure to perform when properly used in accordance with instructions for use provided in the labeling can be reasonably expected to result in significant injury to the user.
- B. A critical component is any component in a life support device or system whose failure to perform can be reasonably expected to cause the failure of the life support device or to affect its safety or effectiveness.

Customers represent that they have all necessary expertise in the safety and regulatory ramifications of their life support devices or systems, and acknowledge and agree that they are solely responsible for all legal, regulatory and safety-related requirements concerning their products and any use of Diodes Incorporated products in such safety-critical, life support devices or systems, notwithstanding any devices- or systems-related information or support that may be provided by Diodes Incorporated. Further, Customers must fully indemnify Diodes Incorporated and its representatives against any damages arising out of the use of Diodes Incorporated products in such safety-critical, life support devices or systems.

Copyright © 2019, Diodes Incorporated

www.diodes.com