

Description

The ZNBG4008 is a GaAs and HEMT FET bias controller intended primarily for satellite Low Noise Blocks (LNBs). With the addition of two capacitors and resistors, the device provides drain voltage and current control for up to 4 external grounded source FETs, generating the regulated negative rail required for FET gate biasing while operating from a single supply. The negative bias, at -3 volts, can also be used to supply other external circuits. In setting drain current, ZNBG4008 uses two resistors to split control between two and four FETs. This allows the operating current of input FETs to be adjusted to minimize noise, while the following FET stages can be separately adjusted for maximum gain.

Features

- Provides Bias for up to 4 GaAs and HEMT FETs
- Operating Range of 5.0 to 12.0V
- Dynamic FET Protection
- Amplifier FET Drain Current Selectable (0 to 15mA)
- Regulated Negative Rail Generator Requires only 2 External Capacitors
- Wide Supply Voltage Range
- QSOP-16 Surface Mount Package
- **Totally Lead-Free & Fully RoHS Compliant (Notes 1 & 2)**
- **Halogen and Antimony Free. "Green" Device (Note 3)**

Notes:

1. No purposely added lead. Fully EU Directive 2002/95/EC (RoHS) & 2011/65/EU (RoHS 2) compliant.
2. See http://www.diodes.com/quality/lead_free.html for more information about Diodes Incorporated's definitions of Halogen- and Antimony-free, "Green" and Lead-free.
3. Halogen- and Antimony-free "Green" products are defined as those which contain <900ppm bromine, <900ppm chlorine (<1500ppm total Br + Cl) and <1000ppm antimony compounds.

Pin Assignments

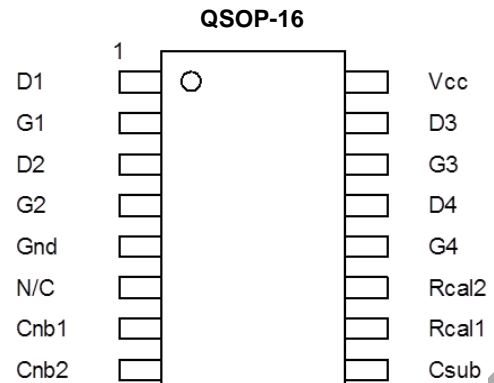

Applications

- Twin LNB's
- Quad LNB's
- Microwave Links
- PMR and Cellular Telephone Systems

Twin LNB System Diagrams

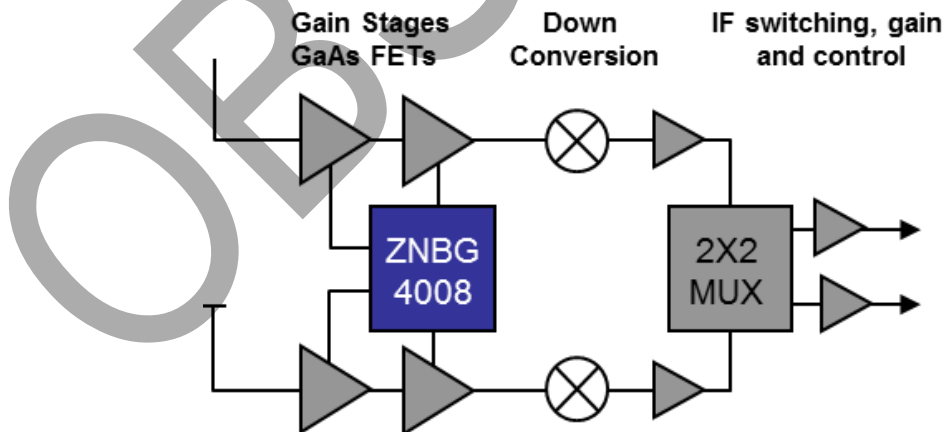

Detailed Description

The ZNBG series of devices are designed to meet the bias requirements of GaAs and HEMT FETs commonly used in satellite receiver LNBS with a minimum of external components while operating from a minimal voltage supply and using minimal current.

The ZNBG4008 has four FET bias stages that can be programmed to provide a constant drain current. Programming of the FET bias stage arrangement and the operating currents of each FET group is achieved by having resistors connected to the R_{CAL1} and R_{CAL2} pins, allowing input FETs to be biased for optimum noise, and amplifier FETs for optimum gain. Amplifier FETs can be operated at currents in the range 0 to 15mA.

Drain voltages of amplifier stages are set at 2.2V and are current limited to the approximate current set by their associated R_{CAL} resistors.

Depletion mode FETs require a negative voltage bias supply when operated in grounded source circuits. The ZNBG4008 includes an integrated switched capacitor DC-DC converter generating a regulated output of -3V to allow single supply operation. The ZNBG4008 is design to be used with supply rails of 5V to 12V.

It is possible to use less than the device's full complement of FET bias controls, and unused drain and gate connections can be left open circuit without affecting operation of the remaining bias circuits.

To protect the external FETs, the circuits are designed to ensure that under any conditions, including power-up/down transients, the gate drive from the bias circuits cannot exceed -3.5V. Additionally, each stage has its own individual current limiter. Furthermore, if the negative rail experiences a fault condition, such as overload or short circuit, the drain supply to the FETs will shut down to avoid excessive current flow.

The ZNBG4008 is available in the 16-pin QSOP-16 package.

The device's operating temperature is -40°C to +70°C in order to suit a wide range of environmental conditions.

Maximum Ratings (@T_A = +25°C, unless otherwise specified.)

Parameter	Rating	Unit
Supply Voltage	-0.6 to +15	V
Supply Current	100	mA
Power Dissipation	500	mW
Junction Temperature	+125	°C
Storage Temperature Range	-40 to +150	°C

Recommended Operating Conditions (Note 4) (@T_A = +25°C, unless otherwise specified.)

Parameter	Symbol	Min.	Max.	Unit
Operating Voltage Range	V _{DD}	4.5	12	V
Operating Temperature Range	T _A	-40	+70	°C

Note: 4. ESD sensitive, handling precautions are recommended.

Electrical Characteristics (@ $T_{AMB} = +25^{\circ}\text{C}$, $V_{CC} = 5\text{V}$, $R_{CAL1} = R_{CAL2} = 33\text{K}$ (setting I_{D1} to I_{D6} to 10mA), unless otherwise stated.)

Parameter	Conditions	Symbol	Min.	Typ.	Max.	Unit
Supply Current	$I_{D1-6} = 0$	I_{CC}	—	—	10	mA
	$I_{D1-6} = 10\text{mA}$	$I_{CC(L)}$	—	—	50	mA
Substrate Voltage (Note 6)	$I_{CSUB} = 0$	V_{CSUB}	-3.5	-3.0	-2.0	V
	$I_{CSUB} = -200\mu\text{A}$	$V_{CSUB(L)}$	—	—	-2.0	V
Oscillator Frequency	—	F_{OSC}	200	350	800	kHz
Drain Voltage (Note 7)	$C_{GATE-GND} = 10\text{nF}$ $C_{DRAIN-GND} = 10\text{nF}$	$V_{D(NOISE)}$	—	—	0.02	Vpk-pk
Gate Voltage (Note 7)	$C_{GATE-GND} = 10\text{nF}$ $C_{DRAIN-GND} = 10\text{nF}$	$V_{G(NOISE)}$	—	—	0.005	Vpk-pk
Gate Characteristics (Pins G1 to G4)						
Current Range	—	I_G	-30	—	2,000	μA
Voltage Low	$I_D = 12\text{mA}$, $I_G = -10\mu\text{A}$	$V_{G(L)}$	-3.5	—	-2.0	V
Voltage High	$I_D = 8\text{mA}$, $I_G = 0$	$V_{G(H)}$	0	—	1.0	V
Drain Characteristics (Pins D1 to D4)						
Current Range	—	I_D	0	—	15	mA
Current Operating (Note 5)	Standard Application Circuit	$I_{D(OP)}$	8	10	12	mA
Voltage Operating	$I_D = 10\text{mA}$	$V_{D(OP)}$	2.0	2.2	2.4	V
Delta V_D vs. V_{CC}	$V_{CC} = 5\text{V}$ to 12V	dV_D/dV_{CC}	—	0.5	—	%/V
Delta V_D vs. T_{OP}	$T_{OP} = -40^{\circ}\text{C}$ to $+100^{\circ}\text{C}$	dV_D/dT_{OP}	—	50	—	ppm

- Notes:
- The characteristics are measured using up to two external reference resistors, R_{CAL1} and R_{CAL2} wired from pins $R_{CAL1/2}$ to ground. Resistor R_{CAL1} sets the drain current of FETs 1 and 3. R_{CAL2} sets the drain currents of FETs 2 and 4.
 - The negative bias voltages are generated on-chip using an internal oscillator. Two external capacitors, C_{NB} and C_{SUB} of value 47nF are required for this purpose.
 - Noise voltage measurements are made with FETs and gate and drain capacitors of value 10nF in place. Noise voltages are not measured in production.

OBSOLETE – PART DISCONTINUED
OBSOLETE

Typical Characteristics (@ $T_{AMB} = +25^{\circ}C$, $V_{CC} = 5V$, $R_{CAL1} = R_{CAL2} = 33K$ (setting I_D to 10mA), unless otherwise stated.)

Drain Current vs. R_{CAL}

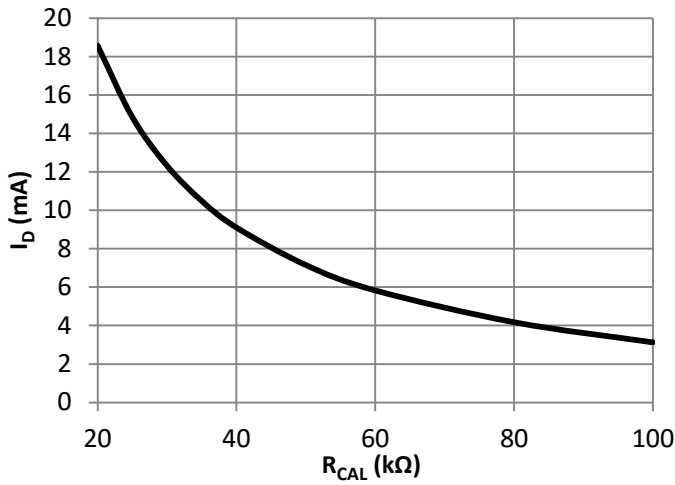

V_{SUB} vs. External Load

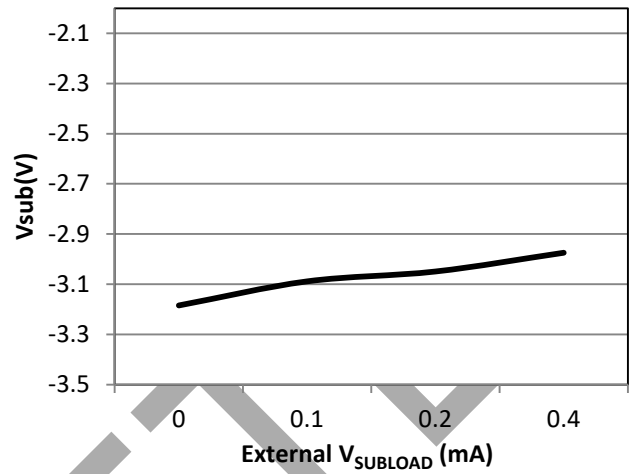

Drain Voltage vs. Drain Current

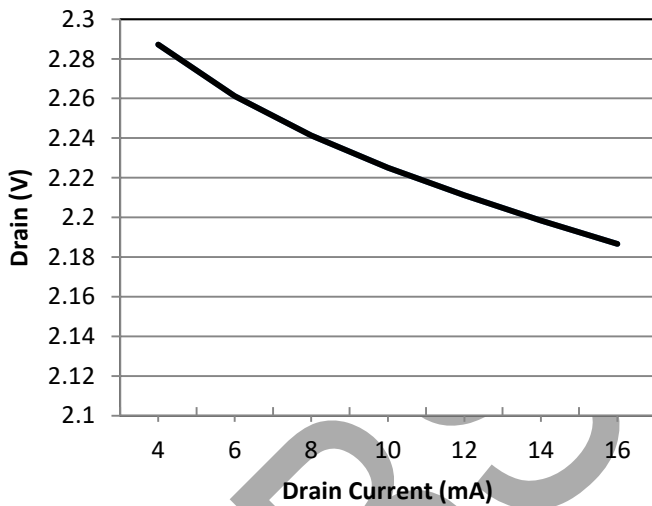

C_{SUB} vs. Temperature

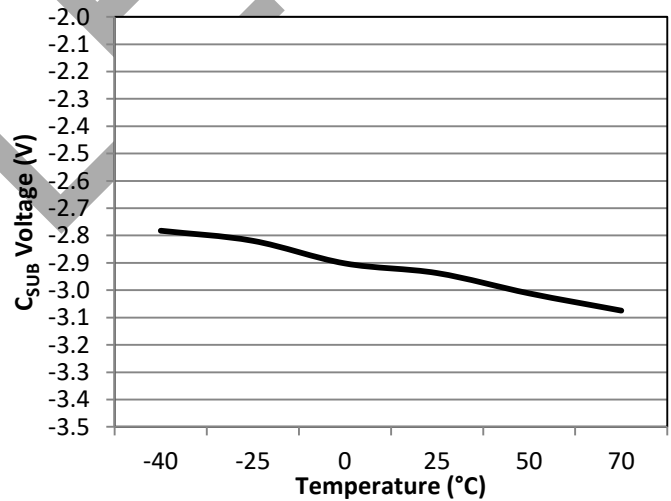

OBSOLETE - PART DISCONTINUED

OBSOLETE

Application Information

Below is a partial applications circuit for the ZNBG4008 showing all external components needed for biasing one of the four FET stages available as a normal LNA bias. Each bias stage is provided with a gate and drain pin. The drain pin provides a regulated 2.2V supply that includes a drain current monitor. The drain current taken by the external FET is compared with a user-selected level, generating a signal that adjusts the gate voltage of the FET to obtain the required drain current. If for any reason, an attempt is made to draw more than the user set drain current from the drain pin, the drain voltage will be reduced to ensure excess current is not taken. The gate pin drivers are also current limited.

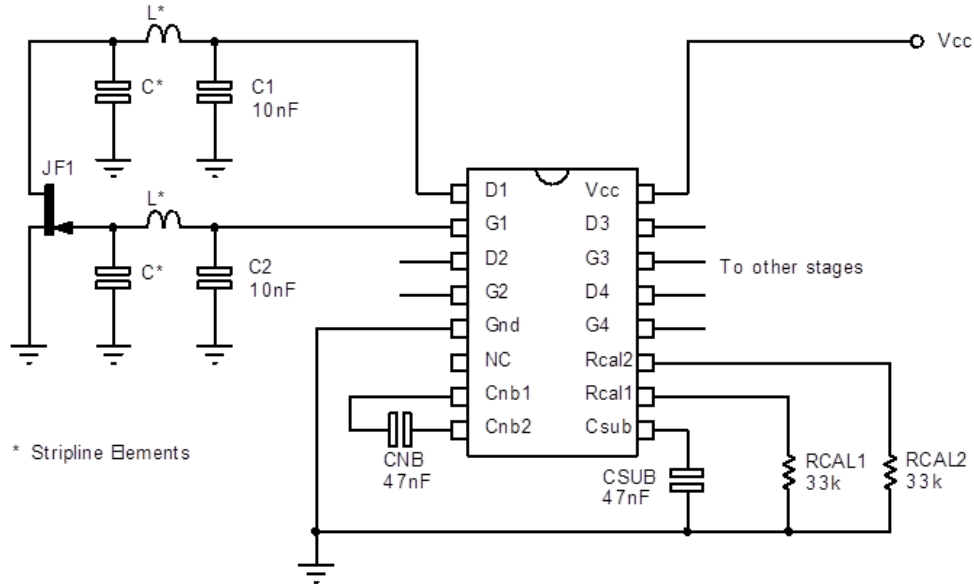

The bias stages are split up into two groups, with the drain current of each group set by an external R_{CAL} resistor. R_{CAL1} sets the drain currents for stages 1 and 3, while R_{CAL2} sets the drain currents for stages 2 and 4. This allows the optimization of drain currents for differing tasks such as input stages where noise can be critical and later amplifier stages where gain may be more important. A graph showing the relationship between the value of R_{CAL} and I_D is provided in the Typical Characteristics section of this datasheet.

The ZNBG4008 includes a switched capacitor DC-DC converter that is used to generate the negative supply required to bias depletion mode FETs used in common source circuit configuration as shown above. This converter uses two external capacitors, C_{NB} , the charge transfer capacitor, and C_{SUB} , the output reservoir capacitor. The circuit provides a regulated -3V supply for both gate driver use and external use, if required (for extra discrete bias stages, mixer bias, local oscillator bias etc.). The -3V supply is available from the C_{SUB} pin.

If any bias stages are not required, their gate and drain pins may be left open circuit. If all bias stages associated with an R_{CAL} resistor are not required, then this resistor may be omitted.

Ordering Information (Note 8)

Device	Package	Reel Size (inches)	Tape Width (mm)	Quantity per Reel
ZNBG4008Q16TC	QSOP-16	13	16	2,500

Note: 8. For packaging details, go to our website at <http://www.diodes.com/products/packages.html>.

Marking Information

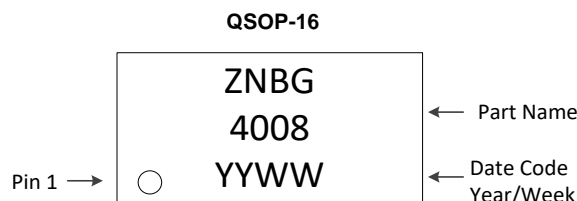

Package Outline Dimensions

Please see <http://www.diodes.com/package-outlines.html> for the latest version.

QSOP-16

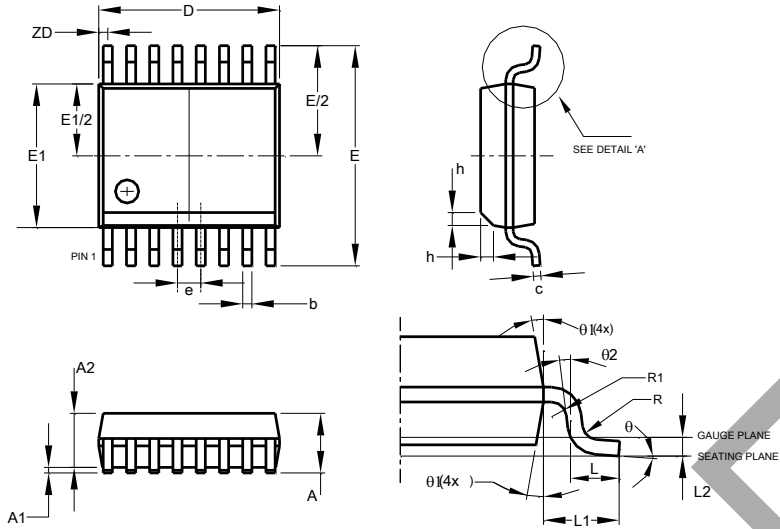

QSOP-16			
Dim	Min	Max	Typ
A	1.55	1.73	-
A1	0.10	0.25	-
A2	1.40	1.50	-
b	0.20	0.30	-
c	0.18	0.25	-
D	4.80	5.00	-
E	5.79	6.20	-
E1	3.81	3.99	-
e	0.635 BSC		
h	0.254	0.508	-
L	0.41	1.27	-
L1	1.03 REF		
L2	0.254 BSC		
R	0.0762	-	-
R1	0.0762	-	-
ZD	0.23 REF		
θ	0°	8°	-
$\theta 1$	5°	15°	-
$\theta 2$	0°	-	-
All Dimensions in mm			

Suggested Pad Layout

Please see <http://www.diodes.com/package-outlines.html> for the latest version.

QSOP-16

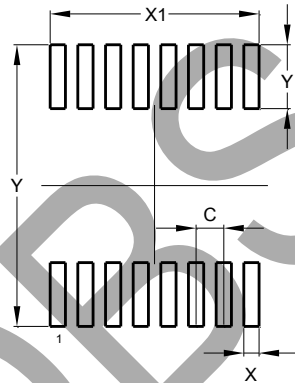

Dimensions	Value (in mm)
C	0.635
X	0.350
X1	4.795
Y	1.450
Y1	6.400

OBSOLETE - PART DISCONTINUED

IMPORTANT NOTICE

1. DIODES INCORPORATED (Diodes) AND ITS SUBSIDIARIES MAKE NO WARRANTY OF ANY KIND, EXPRESS OR IMPLIED, WITH REGARDS TO ANY INFORMATION CONTAINED IN THIS DOCUMENT, INCLUDING, BUT NOT LIMITED TO, THE IMPLIED WARRANTIES OF MERCHANTABILITY, FITNESS FOR A PARTICULAR PURPOSE OR NON-INFRINGEMENT OF THIRD PARTY INTELLECTUAL PROPERTY RIGHTS (AND THEIR EQUIVALENTS UNDER THE LAWS OF ANY JURISDICTION).
2. The Information contained herein is for informational purpose only and is provided only to illustrate the operation of Diodes' products described herein and application examples. Diodes does not assume any liability arising out of the application or use of this document or any product described herein. This document is intended for skilled and technically trained engineering customers and users who design with Diodes' products. Diodes' products may be used to facilitate safety-related applications; however, in all instances customers and users are responsible for (a) selecting the appropriate Diodes products for their applications, (b) evaluating the suitability of Diodes' products for their intended applications, (c) ensuring their applications, which incorporate Diodes' products, comply the applicable legal and regulatory requirements as well as safety and functional-safety related standards, and (d) ensuring they design with appropriate safeguards (including testing, validation, quality control techniques, redundancy, malfunction prevention, and appropriate treatment for aging degradation) to minimize the risks associated with their applications.
3. Diodes assumes no liability for any application-related information, support, assistance or feedback that may be provided by Diodes from time to time. Any customer or user of this document or products described herein will assume all risks and liabilities associated with such use, and will hold Diodes and all companies whose products are represented herein or on Diodes' websites, harmless against all damages and liabilities.
4. Products described herein may be covered by one or more United States, international or foreign patents and pending patent applications. Product names and markings noted herein may also be covered by one or more United States, international or foreign trademarks and trademark applications. Diodes does not convey any license under any of its intellectual property rights or the rights of any third parties (including third parties whose products and services may be described in this document or on Diodes' website) under this document.
5. Diodes' products are provided subject to Diodes' Standard Terms and Conditions of Sale (<https://www.diodes.com/about/company/terms-and-conditions/terms-and-conditions-of-sales/>) or other applicable terms. This document does not alter or expand the applicable warranties provided by Diodes. Diodes does not warrant or accept any liability whatsoever in respect of any products purchased through unauthorized sales channel.
6. Diodes' products and technology may not be used for or incorporated into any products or systems whose manufacture, use or sale is prohibited under any applicable laws and regulations. Should customers or users use Diodes' products in contravention of any applicable laws or regulations, or for any unintended or unauthorized application, customers and users will (a) be solely responsible for any damages, losses or penalties arising in connection therewith or as a result thereof, and (b) indemnify and hold Diodes and its representatives and agents harmless against any and all claims, damages, expenses, and attorney fees arising out of, directly or indirectly, any claim relating to any noncompliance with the applicable laws and regulations, as well as any unintended or unauthorized application.
7. While efforts have been made to ensure the information contained in this document is accurate, complete and current, it may contain technical inaccuracies, omissions and typographical errors. Diodes does not warrant that information contained in this document is error-free and Diodes is under no obligation to update or otherwise correct this information. Notwithstanding the foregoing, Diodes reserves the right to make modifications, enhancements, improvements, corrections or other changes without further notice to this document and any product described herein. This document is written in English but may be translated into multiple languages for reference. Only the English version of this document is the final and determinative format released by Diodes.
8. Any unauthorized copying, modification, distribution, transmission, display or other use of this document (or any portion hereof) is prohibited. Diodes assumes no responsibility for any losses incurred by the customers or users or any third parties arising from any such unauthorized use.
9. This Notice may be periodically updated with the most recent version available at <https://www.diodes.com/about/company/terms-and-conditions/important-notice>

The Diodes logo is a registered trademark of Diodes Incorporated in the United States and other countries.
All other trademarks are the property of their respective owners.
© 2023 Diodes Incorporated. All Rights Reserved.

www.diodes.com