

Description

The DIODES™ ZXBM1004 is a single-phase, DC brushless motor pre-driver with PWM variable speed control suitable for fan and blower motors. The controller is intended for applications where the fan or blower speed is controlled by an external PWM signal, thermistor or DC voltage.

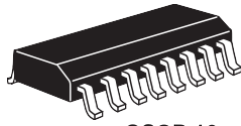

QSOP-16

Pin Assignments

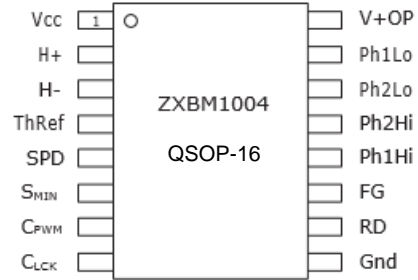

Features

- Compliant with external PWM speed control
- Compliant with thermistor control
- Minimum speed setting
- Low noise
- Auto restart
- Built in hallamplifier
- Speed pulse (FG) and lock rotor (RD) outputs
- Up to 18V input voltage (60V with external regulator)
- QSOP-16 package
- **For automotive applications requiring specific change control (i.e. parts qualified to AEC-Q100/101/104/200, PPAP capable, and manufactured in IATF 16949 certified facilities), please [contact us](#) or your local Diodes representative.**
<https://www.diodes.com/quality/product-definitions/>

Associated Application Notes

- AN41 - Thermistor control AN42 - External PWM control
- AN43 - Interfacing to the motor windings

Applications

- Mainframe and personal computer fans and blowers
- Instrumentation fans
- Central heating blowers
- Automotive climate control

Functional Block Diagram

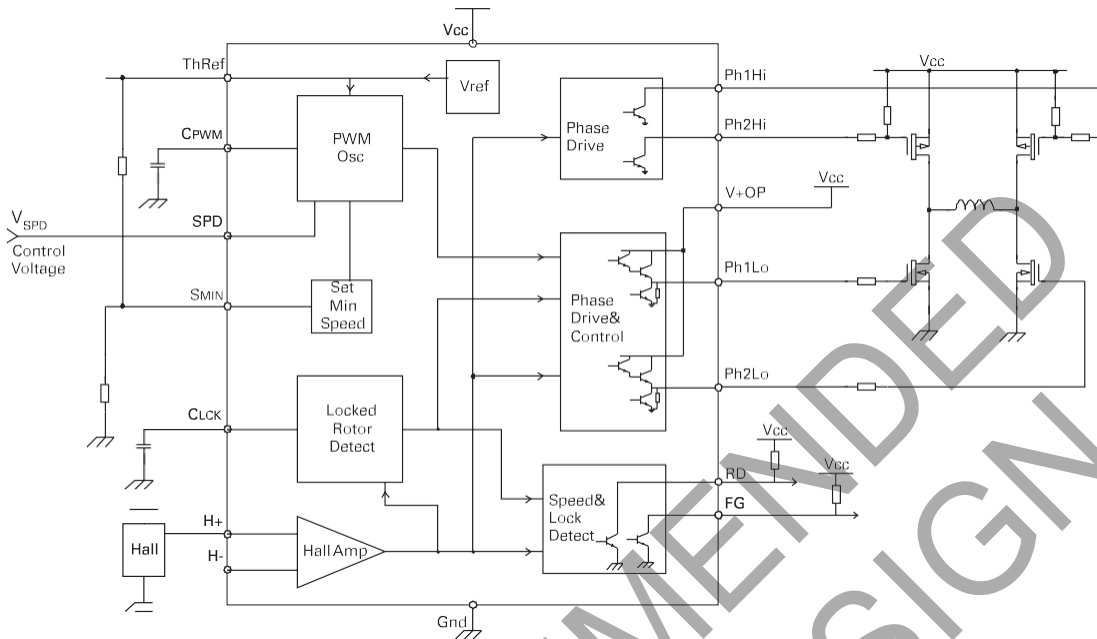

Absolute Maximum Ratings

Parameter	Symbol	Limits	Unit
Supply voltage	$V_{CC\ max}$	-0.6 to 20	V
Input current	$I_{CC\ max}$	200	mA
Input voltage	$V_{IN\ max}$	-0.5 to $V_{CC} + 0.5$	V
Output voltage	$V_{OUT\ max}$	-0.5 to $V_{CC} + 0.5$	V
Power dissipation	$P_D\ max$	500	mW
Operating temp.	T_{OPR}	-40 to 110	°C
Storage temp.	T_{STG}	-55 to 150	°C

Power Dissipation

Maximum allowable Power Dissipation, PD, is shown plotted against Ambient Temperature, TA, in the accompanying Power Derating Curve, indicating the Safe Operating Area for the device.

Power consumed by the device, PT, can be calculated from the equation:

$$P_T = P_Q + P_{PhHi} + P_{PhLo}$$

where PQ is power dissipated under quiescent current conditions, given by:

$$P_Q = V_{CC} \times I_{CC}$$

where VCC is the application device Supply Voltage

an ICC is the maximum Supply Current given in the Electrical Characteristics

and PPHi is power generated due to either one of the phase outputs Ph1Hi or Ph2Hi being active, given by:

$$P_{PhHi} = I_{OL} \times V_{OL}$$

where IOL is the application Ph1Hi and Ph2Hi output currents

an VOL is the maximum Low Level Output Voltage for the Ph1Hi and Ph2Hi outputs given in the Electrical Characteristics

and PPHLo is power generated due to either one of the phase outputs Ph1Lo or Ph2Lo being active, given by:

$$P_{PhLo} = I_{OH} \times (V_{CC} - V_{OH})$$

where IOH is the application Ph1Lo and Ph2Lo output currents

and VCC is the application device Supply Voltage

and VOH is the minimum High Level Output Voltage for the Ph1Lo and Ph2Lo outputs given in the Electrical Characteristics

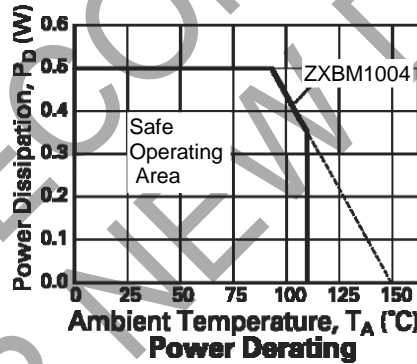

Electrical Characteristics (@T_A = +25°C & V_{CC} = 12V)

Parameter	Symbol	Min	Typ	Max	Unit	Conditions
Supply Voltage	V _{CC}	4.7	—	18	V	—
Supply Current	I _{CC}	—	6	8.5	mA	No load (Note 1)
Hall Amp Input Voltage	V _{IN}	40	—	—	mV	diff p-p
Hall Amp Common Mode Voltage	V _{CM}	0.5	—	V _{CC} -1.5	V	—
Hall Amp Input Offset	V _{OFS}	—	±7	—	mV	—
Hall Amp Bias Current	I _{BS}	—	400	650	nA	—
Ph1Lo, Ph2Lo Output High Voltage	V _{OH}	V _{CC} -2.2	V _{CC} -1.8	—	V	I _{OH} = 80mA
Ph1Lo, Ph2Lo Output Low Voltage	V _{OLA}	—	0.4	0.6	V	I _{OL} = 16mA (Note 2)
Ph1Lo, Ph2Lo Output Low Voltage	V _{OLB}	—	0.4	0.6	V	I _{OL} = 50μA (Note 3)
Ph1Lo, Ph2Lo Output Source Current	I _{OH}	—	—	-80	mA	—
Ph1Lo, Ph2Lo Output Sink Current	I _{OL}	—	—	16	mA	—
Ph1Hi, Ph2Hi Output Low Voltage	V _{OL}	—	0.5	0.7	V	I _{OL} = 100mA
Ph1Hi, Ph2Hi Output Sink Current	I _{OL}	—	—	100	mA	—
CPWM Charge Current	I _{PWMC}	-6.2	-7.6	-9	μA	—
CPWM Discharge Current	I _{PWMD}	65	80	95	μA	—
CPWM High Threshold Voltage	V _{THH}	2.95	3	3.15	V	—
CPWM Low Threshold Voltage	V _{THL}	0.94	1	1.11	V	—
PWM Frequency	F _{PWM}	—	24	—	kHz	C _{PWM} = 0.1nF
ThRef Voltage	V _{ThRef}	2.925	3.0	3.14	V	I _{O ThRef} = -100μA
ThRef Output Current	I _{O ThRef}	—	-0.2	-1	mA	—
SMIN Input Current	I _{SMIN}	—	-0.25	-0.5	μA	V _{in} = 2V
SPD Voltage Minimum	V _{SPDL}	—	1	—	V	100% PWM drive
SPD Voltage Maximum	V _{SPDH}	—	3	—	V	0% PWM drive
SPD Input Current	I _{SPD}	—	-0.8	-2	μA	V _{in} = 2V
CLCK Charge Current	I _{LCKC}	-2	-3	—	μA	—
CLCK Discharge Current	I _{LCKD}	—	0.2	0.35	μA	—
CLCK High Threshold Voltage	V _{THH}	—	3	—	V	—
CLCK Low Threshold Voltage	V _{THL}	—	1	—	V	—
Lock Condition On: Off Ratio	—	—	1:12	—	—	—
FG & RD Output Current	I _{OL}	—	—	5	mA	—
FG & RD Low Level Output Voltage	V _{OL}	—	—	0.5	V	I _{OL} = 5mA

Notes:
 1. Measured with pins H+, H-, CLCK and CPWM = 0V and all other signal pins open circuit.
 2. Measured when opposing phase output is low.
 3. Measured when opposing phase output is high.

Pin Functional Description

H+ - Hall input

H- - Hall input

The rotor position is detected by a Hall sensor, with the output applied to the H+ and H- pins. This sensor can be either a 4 pin 'naked' Hall device or of the 3 pin buffered switching type. For a 4 pin device the differential Hall output signal is connected to the H+ and H- pins. For a buffered Hall sensor, the Hall device output is attached to the H+ pin, with a pull-up attached if needed, whilst the H- pin has an external potential divider attached to hold the pin at half V_{CC}. When H+ is high in relation to H-, Ph2 is the active drive.

ThRef - Network Reference

This is a reference voltage of nominal 3V. It is designed for the ability to 'source' and therefore it will not 'sink' any current from a higher voltage. The total current drawn from the pin by the minimum speed potential divider to pin S_{MIN} and any voltage setting network should not exceed 1mA at maximum temperature.

SPD - Speed Control Input

The voltage applied to the SPD pin provides control over the Fan Motor speed by varying the Pulse Width Modulated (PWM) drive ratio at the Ph1Lo and Ph2Lo outputs. The control signal takes the form of a voltage input of range 3V to 4V, representing 0% to 100% drive respectively.

If variable speed control is not required, this pin can be left with an external potential divider to set a fixed speed or tied to ground to provide full speed i.e. 100% PWM drive.

If required, this pin can also be used as an enable pin. The application of a voltage >3.0V will force the PWM drive fully off, in effect disabling the drive.

S_{MIN}-Sets Minimum Speed

A voltage can be set on this pin via a potential divider between the ThRef and Gnd. This voltage is monitored by the SPD pin such that it cannot rise above it. As a higher voltage on the SPD pin represents a lower speed it therefore restricts the lower speed range of the fan. If this feature is not required, the pin is left tied to ThRef so no minimum speed will be set.

If the fan is being controlled from an external voltage source onto the SPD pin, then either this feature should not be used or if it is required then a >1k Δ resistor should be placed in series with the SPD pin.

C_{PWM}-Sets PWM Frequency

This pin has an external capacitor attached to set the PWM frequency for the Phase drive outputs. A capacitor value of 0.1nF will provide a PWM frequency of typically 24kHz.

The C_{PWM} timing period (T_{PWM}) is determined by the following equation:

$$T_{PWM} = \frac{(V_{THH} - V_{THL}) \times C}{I_{PWMC}} + \frac{(V_{THH} - V_{THL}) \times C}{I_{PWMD}}$$

Where: C = C_{PWM} + 15, in pF

V_{THH} and V_{THL} are the C_{PWM} pin threshold voltages

I_{PWMC} and I_{PWMD} are the charge and discharge currents in μ A.

T_{PWM} is in ms

As these threshold voltages are nominally set to V_{THH} = 3V and V_{THL} = 1V the equations can be simplified as follows:

$$T_{PWM} = \frac{2C}{I_{PWMC}} + \frac{2C}{I_{PWMD}}$$

CLCK - Locked Rotor Timing Capacitor

Should the fan stop rotating for any reason, i.e. an obstruction in the fan blade or a seized bearing, then the device will enter a Rotor Locked condition. In this condition after a predetermined time (T_{LOCK}) the RD pin will go high and the Phase outputs will be disabled. After a further delay (T_{OFF}) the controller will re-enable the Phase drive for a defined period (T_{ON}) in an attempt to re-start the fan. This cycle of (T_{OFF}) and (T_{ON}) will be repeated indefinitely or until the fan re-starts.

GND - Ground

This is the device supply ground return pin and will generally be the most negative supply pin to the fan.

Pin Functional Description (Continued)

RD - Locked Rotor Error Output

This pin is the Locked Rotor output as referred to in the CLCK timing section above. It is high when the rotor is stopped and low when it is running. This is an open collector drive giving an active pull down with the high level being provided by an external pull up resistor.

FG - Frequency Generator (Speed) Output

This is the Frequency Generator output and is a buffered signal from the Hall sensor.

This is an open collector drive giving an active pull down with the high level being provided by an external pull up resistor.

Ph1Lo & Ph2Lo - Low-side External H-bridge Driver

This pair of outputs drive the Low side of the external high power H-bridge devices which in turn drives the single phase winding. These outputs provide both the commutation and PWM waveforms. The outputs are of the Darlington emitter follower type with an active pull-down to help faster switch off when using bipolar devices. When in the high state the outputs will provide up to 80mA of drive into the base or gates of external transistors as shown in the Typical Application circuit following.

When in the low state the active Phase drive is capable of sinking up to 16mA when driving low to aid turn off times during PWM operation. When the Phase is inactive the output is held low by an internal pull-down resistor.

Ph1Hi & Ph2Hi - High-side External H-bridge Driver

These are the High side outputs to the external H-bridge and are open collector outputs capable of sinking 100mA. This signal provides commutation only to the H-bridge.

V+OP - Phase Outputs Supply Voltage

This pin is the supply to the Phase outputs and will be connected differently dependent upon external transistor type.

For bipolar devices this pin will be connected by a resistor to the VCC pin. The resistor is used to control the current into the transistor base so its value is chosen accordingly.

For MOSFET devices the pin will connect directly to the Vcc pin.

VCC - Applied Voltage

This is the device internal circuitry supply voltage. For 5V to 12V fans this can be supplied directly from the Fan Motor supply. For fans likely to run in excess of the 18V maximum rating for the device this will be supplied from an external regulator such as a Zener diode.

RD Timing Waveform

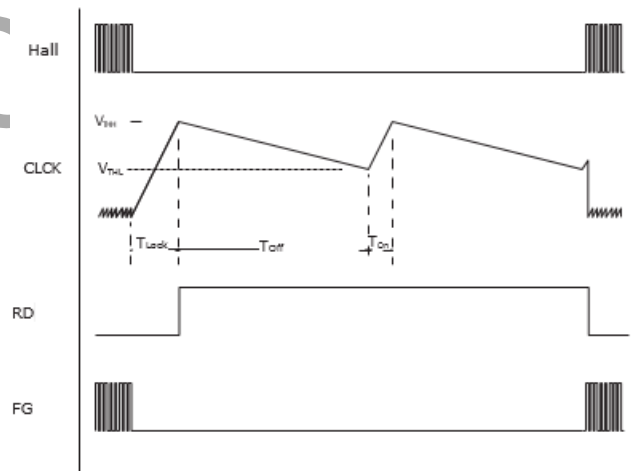

Application Information

The ZXBM1004 is primarily controlled by a voltage on the SPD pin. A voltage of 1V represents a 100% PWM at the Phase Outputs and in turn represents full speed. 3V on the SPD pin conversely represents 0% PWM. The motor can therefore be controlled simply by applying a control voltage onto the SPD pin with the minimal use of external components.

This voltage control method easily lends itself to control by other signal types. For example, if a thermistor is applied to the SPD pin a varying voltage can be generated at the SPD pin as the resistance of the thermistor varies with temperature.

A common form of control of fans is by a PWM signal derived from a central processor or controller. This signal can be converted into a voltage and that voltage adjusted as necessary to compensate for motor non linearity, inclusion of the Minimum speed feature etc.

Full applications detail and further examples of how to control the ZXBM1004 are available in the Applications Notes AN41, AN42 and AN43.

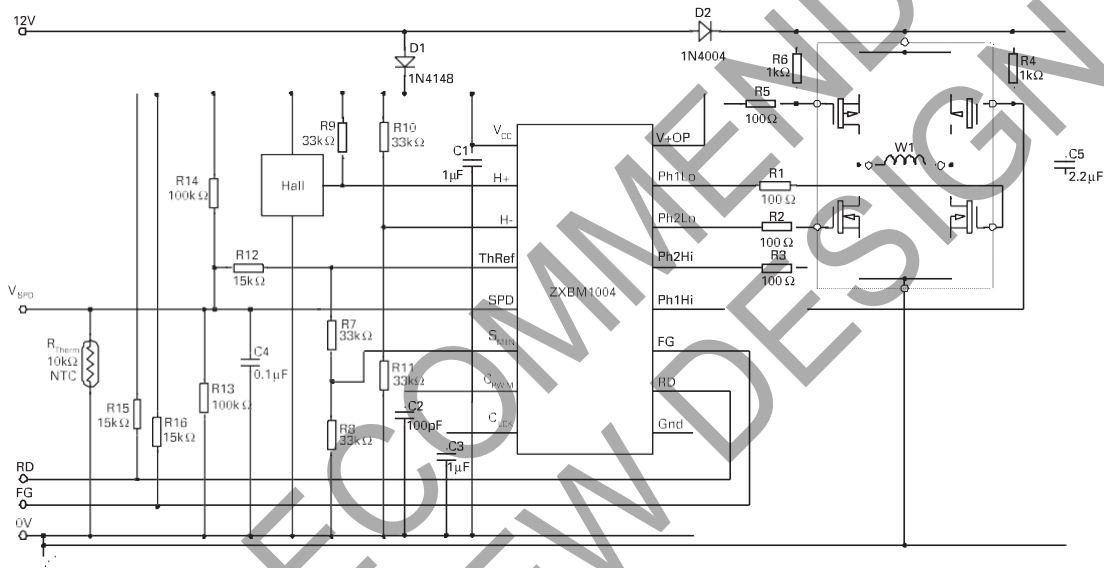

Figure 1. Typical Circuit for Thermistor Controlled Speed

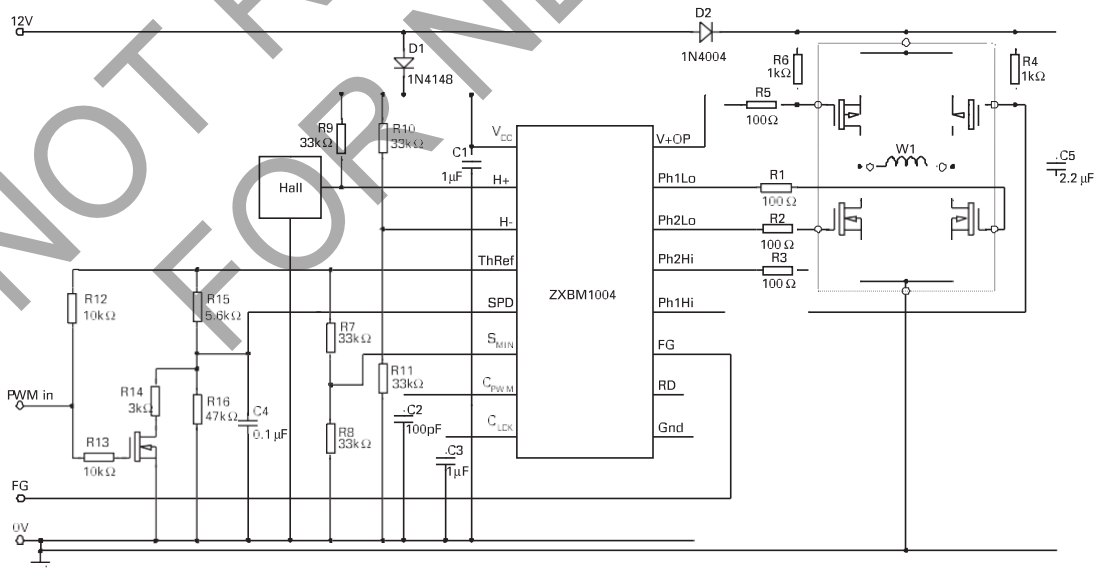

Figure 2. Typical Circuit for External PWM Controlled Speed

Application Information (Continued)

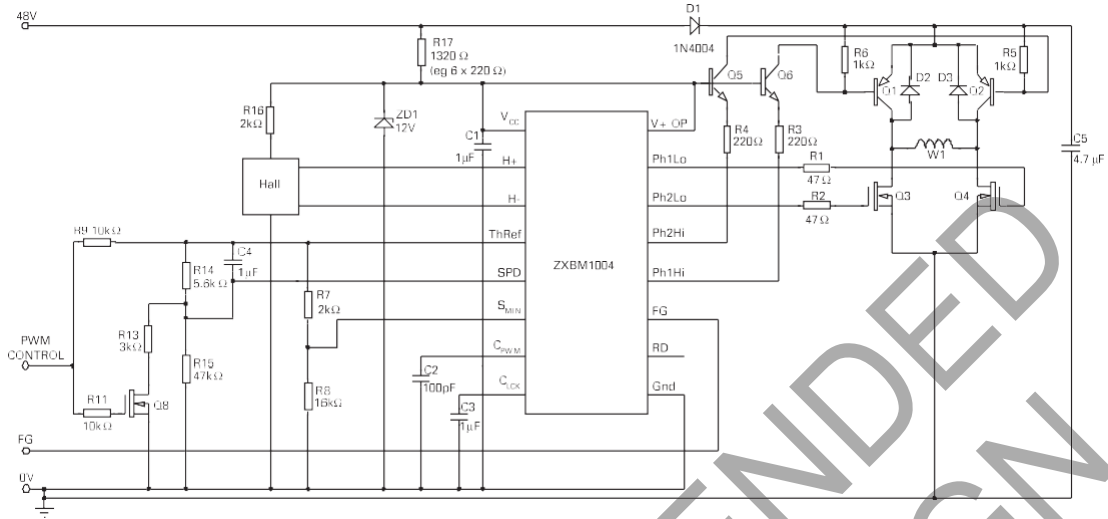

Figure 3. Typical Circuit for 48V Input and External PWM Control

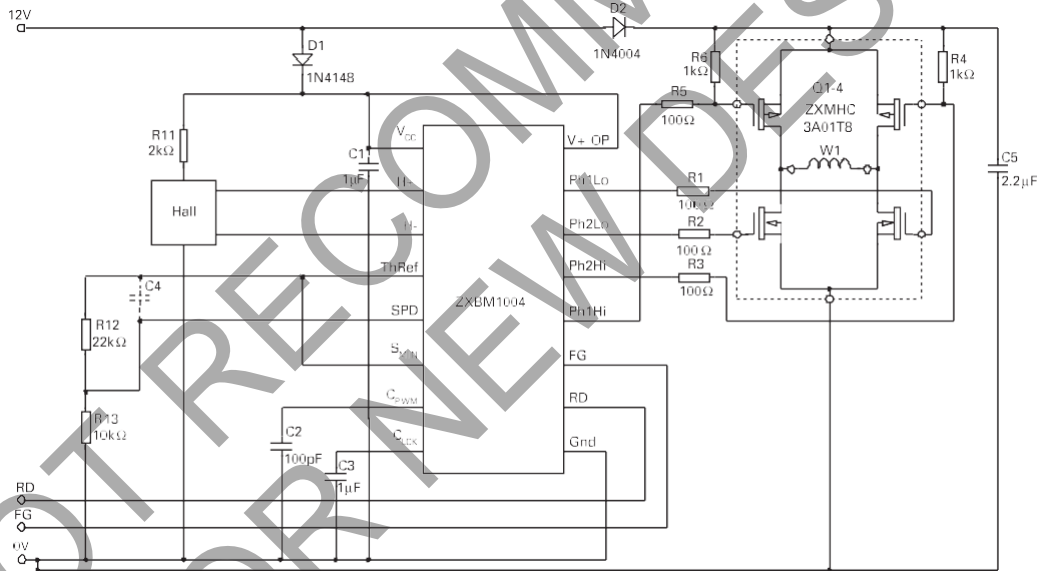

Figure 4. Typical Circuit for Constant Speed Operation

Drive Transistors

Diodes Incorporated offers a range of devices that are ideally suited to interface between the ZXBM1004 controller and the motor. The following tables show a selection of products ranging from single packaged H-bridge devices to individual power components that can be used in this application. If your needs are not covered by this selection then please refer to the more comprehensive listings that can be found on the Diodes Incorporated's website: www.diodes.com.

Description	Part Number	Content	BV_{DSS} V	I_D A	I_{DM} A	$R_{DS(ON)}$ @ $V_{GS} = 10V$ max. m Ω	Package
MOSFET H-Bridge	ZXMHC6A07T8	2 x N	60	1.8	8.7	300	SM-8
		2 x P	-60	-1.5	-7.5	425	
	ZXMHC3A01T8	2 x N	30	3.1	14.5	120	SM-8
		2 x P	-30	-2.3	-10.8	210	
N + P Channel MOSFET	ZXMC4559DN8	N	60	4.7	22	55	SO8
		P	-60	-3.5	-18	105	
	ZXMC3A16DN8	N	30	6.4	30	35	SO8
		P	-30	-5.4	-25	48	
Low Side Switch MOSFET	ZXMN10A09K	N	100	7.7	27	85	DPAK
	ZXMN6A09K	N	60	11.2	40	45	
	ZXMN3A04K	N	30	18.4	66	20	

Description	Part Number	Content	BV_{CEO} V	I_C A	I_{CM} A	$V_{CE(sat)}$ @ $I_C = 2A$ max. mV	Package
High Side Switch Bipolar	ZXT953K	PNP	-100	-5	-10	-175	DPAK
	ZXT951K	PNP	-60	-6	-15	-165	
	ZXT790AK	PNP	-40	-3	-6	-450	

Marking Information

Device	Package	Reel Size	Tape Width	Package	
				Qty.	Carrier
ZXBM1004Q16TA	QSOP-16	7" (180mm)	12mm	500	Reel
ZXBM1004Q16TC	QSOP-16	13" (330mm)	12mm	2,500	Reel

Device Marking

- ZETEX
- ZXBM
- 1004

Package Outline Dimensions

Please see <http://www.diodes.com/package-outlines.html> for the latest version.

QSOP-16

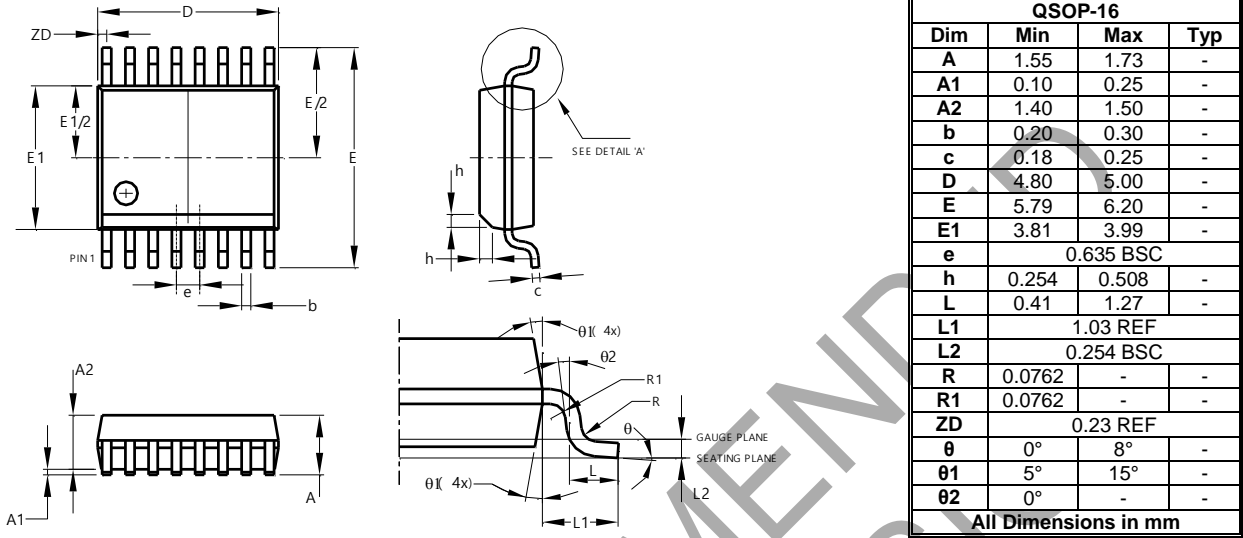

Suggested Pad Layout

Please see <http://www.diodes.com/package-outlines.html> for the latest version.

QSOP-16

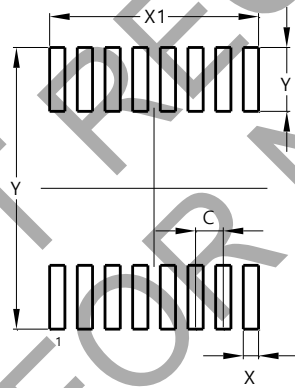

Dimensions	Value (in mm)
C	0.635
X	0.350
X1	4.795
Y	1.450
Y1	6.400

IMPORTANT NOTICE

1. DIODES INCORPORATED (Diodes) AND ITS SUBSIDIARIES MAKE NO WARRANTY OF ANY KIND, EXPRESS OR IMPLIED, WITH REGARDS TO ANY INFORMATION CONTAINED IN THIS DOCUMENT, INCLUDING, BUT NOT LIMITED TO, THE IMPLIED WARRANTIES OF MERCHANTABILITY, FITNESS FOR A PARTICULAR PURPOSE OR NON-INFRINGEMENT OF THIRD PARTY INTELLECTUAL PROPERTY RIGHTS (AND THEIR EQUIVALENTS UNDER THE LAWS OF ANY JURISDICTION).
2. The Information contained herein is for informational purpose only and is provided only to illustrate the operation of Diodes' products described herein and application examples. Diodes does not assume any liability arising out of the application or use of this document or any product described herein. This document is intended for skilled and technically trained engineering customers and users who design with Diodes' products. Diodes' products may be used to facilitate safety-related applications; however, in all instances customers and users are responsible for (a) selecting the appropriate Diodes products for their applications, (b) evaluating the suitability of Diodes' products for their intended applications, (c) ensuring their applications, which incorporate Diodes' products, comply the applicable legal and regulatory requirements as well as safety and functional-safety related standards, and (d) ensuring they design with appropriate safeguards (including testing, validation, quality control techniques, redundancy, malfunction prevention, and appropriate treatment for aging degradation) to minimize the risks associated with their applications.
3. Diodes assumes no liability for any application-related information, support, assistance or feedback that may be provided by Diodes from time to time. Any customer or user of this document or products described herein will assume all risks and liabilities associated with such use, and will hold Diodes and all companies whose products are represented herein or on Diodes' websites, harmless against all damages and liabilities.
4. Products described herein may be covered by one or more United States, international or foreign patents and pending patent applications. Product names and markings noted herein may also be covered by one or more United States, international or foreign trademarks and trademark applications. Diodes does not convey any license under any of its intellectual property rights or the rights of any third parties (including third parties whose products and services may be described in this document or on Diodes' website) under this document.
5. Diodes' products are provided subject to Diodes' Standard Terms and Conditions of Sale (<https://www.diodes.com/about/company/terms-and-conditions/terms-and-conditions-of-sales/>) or other applicable terms. This document does not alter or expand the applicable warranties provided by Diodes. Diodes does not warrant or accept any liability whatsoever in respect of any products purchased through unauthorized sales channel.
6. Diodes' products and technology may not be used for or incorporated into any products or systems whose manufacture, use or sale is prohibited under any applicable laws and regulations. Should customers or users use Diodes' products in contravention of any applicable laws or regulations, or for any unintended or unauthorized application, customers and users will (a) be solely responsible for any damages, losses or penalties arising in connection therewith or as a result thereof, and (b) indemnify and hold Diodes and its representatives and agents harmless against any and all claims, damages, expenses, and attorney fees arising out of, directly or indirectly, any claim relating to any noncompliance with the applicable laws and regulations, as well as any unintended or unauthorized application.
7. While efforts have been made to ensure the information contained in this document is accurate, complete and current, it may contain technical inaccuracies, omissions and typographical errors. Diodes does not warrant that information contained in this document is error-free and Diodes is under no obligation to update or otherwise correct this information. Notwithstanding the foregoing, Diodes reserves the right to make modifications, enhancements, improvements, corrections or other changes without further notice to this document and any product described herein. This document is written in English but may be translated into multiple languages for reference. Only the English version of this document is the final and determinative format released by Diodes.
8. Any unauthorized copying, modification, distribution, transmission, display or other use of this document (or any portion hereof) is prohibited. Diodes assumes no responsibility for any losses incurred by the customers or users or any third parties arising from any such unauthorized use.
9. This Notice may be periodically updated with the most recent version available at <https://www.diodes.com/about/company/terms-and-conditions/important-notice>

DIODES is a trademark of Diodes Incorporated in the United States and other countries.
The Diodes logo is a registered trademark of Diodes Incorporated in the United States and other countries.
© 2022 Diodes Incorporated. All Rights Reserved.

www.diodes.com