

Description

The ZXCT1081 is a high-side current sense monitor with a gain of 10 and a voltage output. Using this device eliminates the need to disrupt the ground plane when sensing a load current.

The wide input voltage range of 40V down to as low as 3V makes it suitable for a range of applications, including systems operating from industrial 24V to 28V rails and power supplies.

Pin Assignments

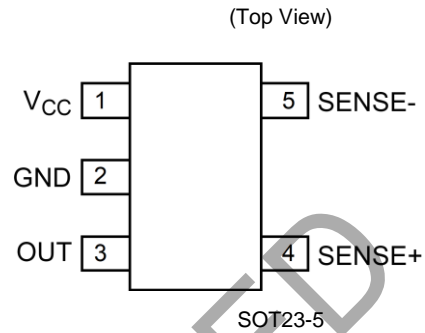

Features

- 3V to 40V continuous high-side voltage
- Accurate high-side current sensing
- Output voltage scaling x10
- 4.5V to 12V V_{CC} range
- Low quiescent current:
 - 80 μ A supply pin
 - 30 μ A I_{SENSE+}
- SOT23-5 package
- -40°C to +125°C ambient temperature range
- **An automotive-compliant part is available under separate datasheet ([ZXCT1081Q](#))**

Applications

- Automotive current measurement
- Industrial applications current measurement
- Battery management
- Overcurrent monitors
- Power management
- Power adapters

Typical Application Circuit

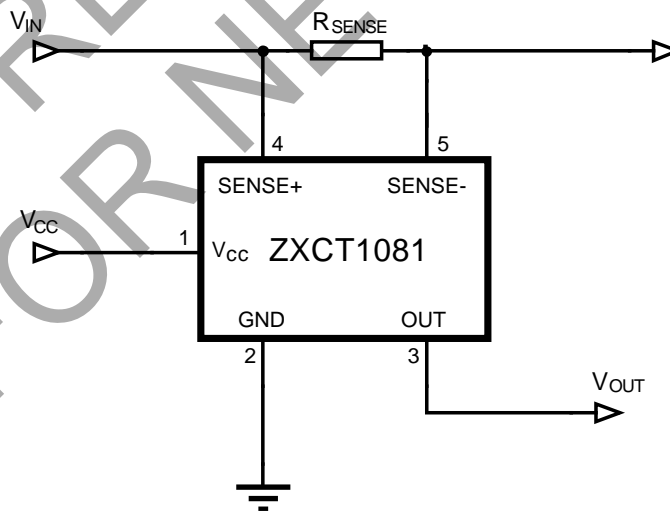

Pin Description

Pin Number	Pin Name	Description
1	V _{CC}	This is the analog supply and provides power to internal circuitry.
2	GND	Ground pin
3	OUT	Output voltage pin. nMOS source follower with 20µA bias to ground.
4	SENSE+	This is the positive input of the current monitor and has an input range from 40V (60V transient) down to 3V. The current through this pin varies with differential sense voltage.
5	SENSE-	This is the negative input of the current monitor and has an input range from 40V (60V transient) down to 3V.

Absolute Maximum Ratings (Note 1)

Parameter	Rating	Unit
Continuous Voltage on SENSE+ and SENSE-	-0.6 and 45	V
Transient Voltage on SENSE+ and SENSE-	-0.6 and 65	V
Voltage on All Other Pins	-0.6 and 14	V
Differential Sense Voltage, V _{SENSE}	800	mV
Operating Temperature	-40 to +125	°C
Storage Temperature	-55 to +150	°C
Maximum Junction Temperature	+125	°C
Package Power Dissipation	300 @ T _A = +25°C (de-rate to zero at +125°C)	mW

Note: 1. Stresses greater than those listed under *Absolute Maximum Ratings* can cause permanent damage to the device. These are stress ratings only, and functional operation of the device at these or any other conditions beyond those indicated under *Recommended Operating Conditions* is not implied. Exposure to *Absolute Maximum Ratings* for extended periods can affect device reliability.

Recommended Operating Conditions

Symbol	Parameter	Min	Max	Units
V _{IN}	Common-Mode Sense+ Input Range	3	40	V
V _{CC}	Supply Voltage Range	4.5	12	V
V _{SENSE}	Differential Sense Input Voltage Range	0	0.15	V
V _{OUT}	Output Voltage Range	0	1.5	V
T _J	Ambient Temperature Range	-40	+125	°C

Electrical Characteristics (Test conditions: $T_A = +25^\circ\text{C}$, $V_{IN} = 12\text{V}$, $V_{CC} = 5\text{V}$, $V_{SENSE} = 100\text{mV}$ (Note 2), unless otherwise stated.)

Symbol	Parameter	Condition	Min	Typ	Max	Unit
I_{CC}	VCC Supply Current	$V_{CC} = 12\text{V}$	40	80	120	μA
I_{SENSE+}	SENSE+ Input Current	—	15	30	60	μA
I_{SENSE-}	SENSE- Input Current	—	10	40	80	nA
$V_{O(0)}$	Zero V_{SENSE} Error (Notes 2, 3)	$V_{SENSE} = 0\text{V}$ (Note 2)	0	—	35	mV
$V_{O(10)}$	Output Offset Voltage (Note 4)	$V_{SENSE} = 10\text{mV}$ (Note 2)	-30	—	+30	mV
Gain	$\Delta V_{OUT}/\Delta V_{SENSE}$ (Note 2)	$V_{SENSE} = 10\text{mV}$ to 150mV (Note 2)	9.95	10	10.05	—
V_{OUTTC} (Note 5)	V_{OUT} Variation with Temperature	—	—	30	—	ppm/ $^\circ\text{C}$
Acc	Total Output Error	—	-3	—	3	%
I_{OH}	Output Source Current	$V_{OUT} = 30\text{mV}$	—	1	—	mA
I_{OL}	Output Sink Current	$V_{OUT} = +30\text{mV}$	—	20	—	μA
PSRR	VCC Supply Rejection Ratio	$V_{CC} = 4.5\text{V}$ to 12V	54	60	—	dB
CMRR	Common-Mode Sense Rejection Ratio	$V_{IN} + 40\text{V}$ to 3V	60	75	—	dB
BW	-3dB Small-Signal Bandwidth	$V_{SENSE(AC)} = 10\text{mV}_{PP}$ (Note 2)	—	50	—	kHz

- Notes:
- $V_{SENSE} = "V_{SENSE+}" - "V_{SENSE-}"$.
 - The ZXCT1081 operates from a positive power rail and the internal voltage-current converter current flow is uni-directional; these result in the output offset voltage for $V_{SENSE} = 0\text{V}$ always being positive.
 - For $V_{SENSE} > 10\text{mV}$, the internal voltage-current converter is fully linear. This enables a true offset to be defined and used. $V_{O(10)}$ is expressed as the variance about an output voltage of 100mV .
 - Temperature dependent measurements are extracted from characterization and simulation results.

NOT RECOMMENDED FOR NEW DESIGN

Typical Operating Conditions (Test conditions: $T_A = +25^\circ\text{C}$, $V_{CC} = 5\text{V}$, $V_{S\text{ENSE}+} = 12\text{V}$, $V_{S\text{ENSE}} = 100\text{mV}$)

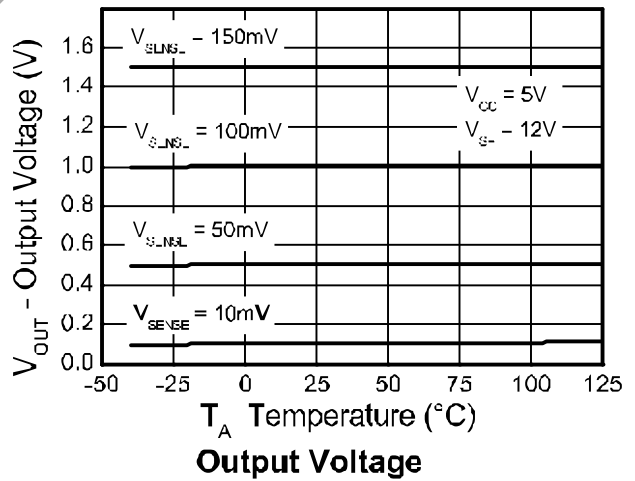
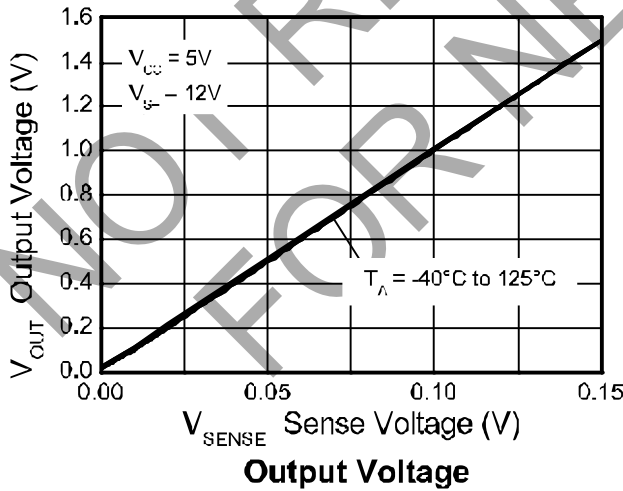
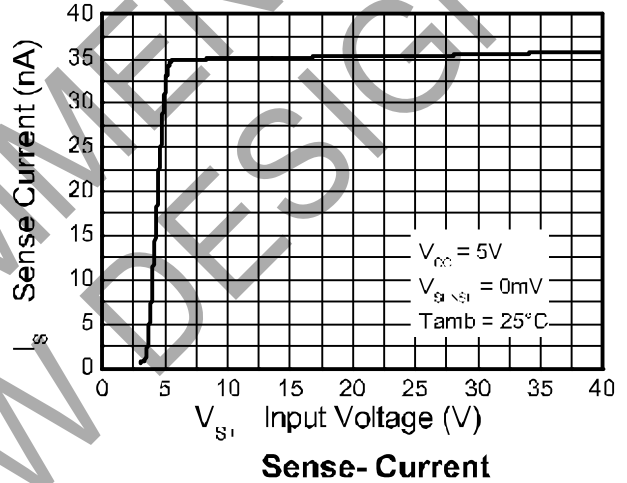
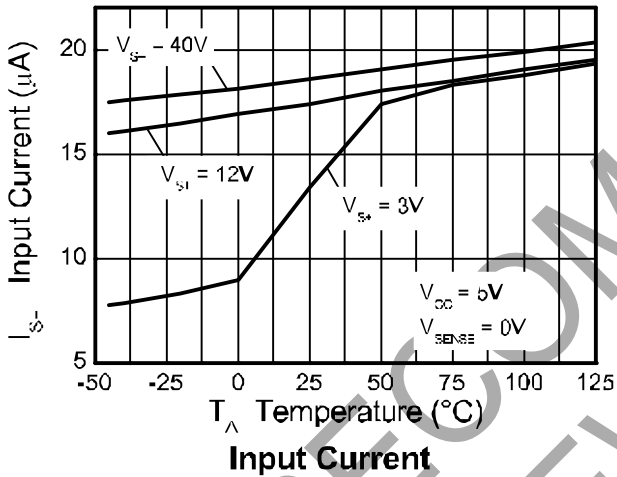
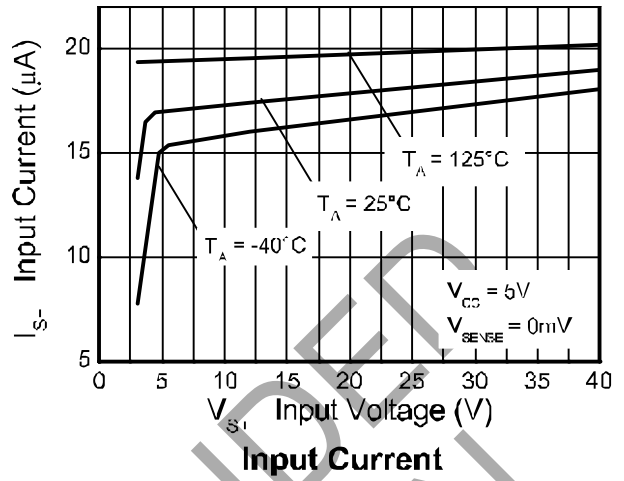
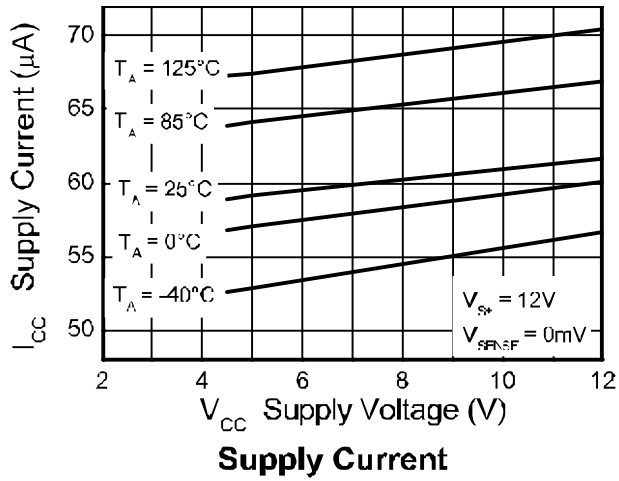

Typical Operating Conditions (continued) (Test conditions: $T_A = +25^\circ\text{C}$, $V_{CC} = 5\text{V}$, $V_{SENSE+} = 12\text{V}$, $V_{SENSE} = 100\text{mV}$)

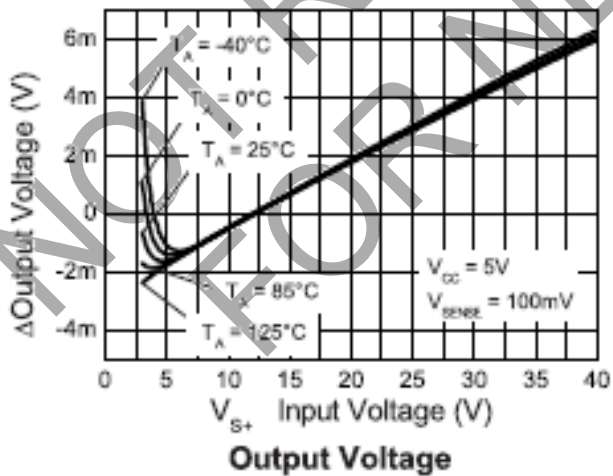
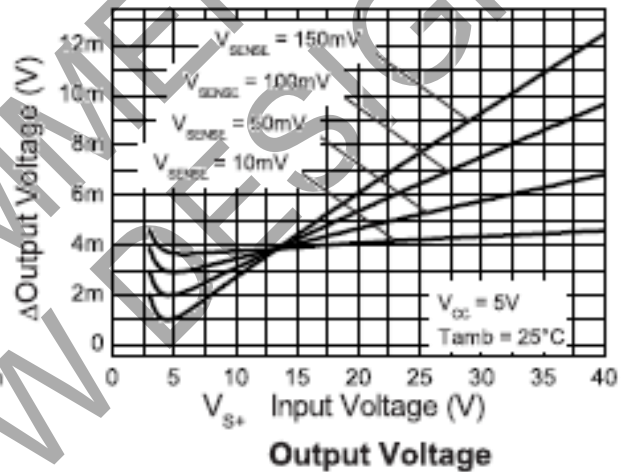
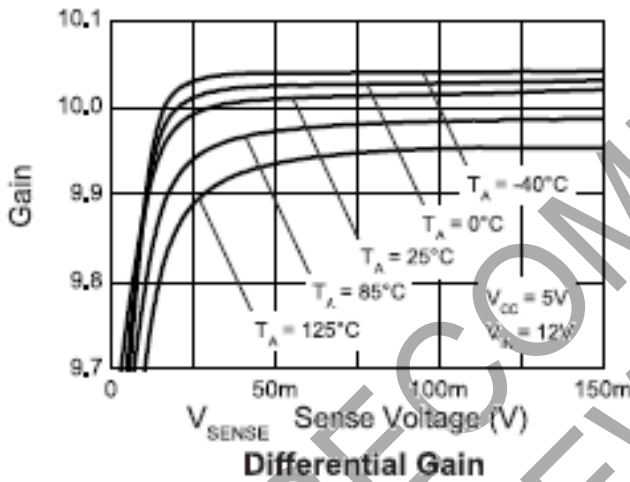
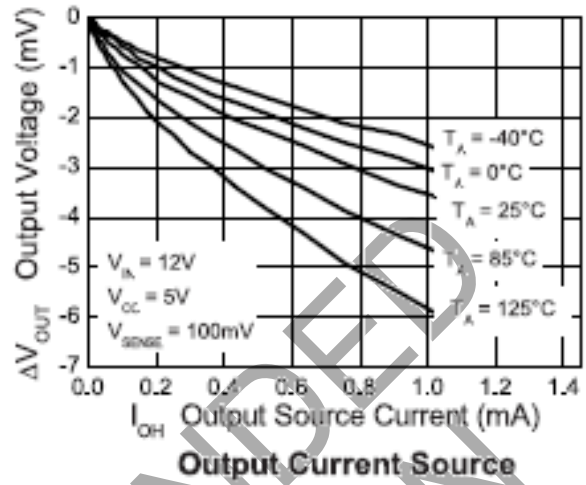
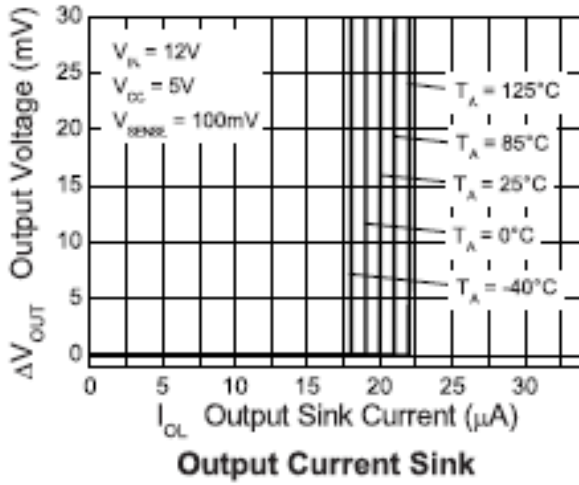

Typical Operating Conditions (continued) (Test conditions: $T_A = +25^\circ\text{C}$, $V_{CC} = 5\text{V}$, $V_{\text{SENSE}+} = 12\text{V}$, $V_{\text{SENSE}} = 100\text{mV}$)

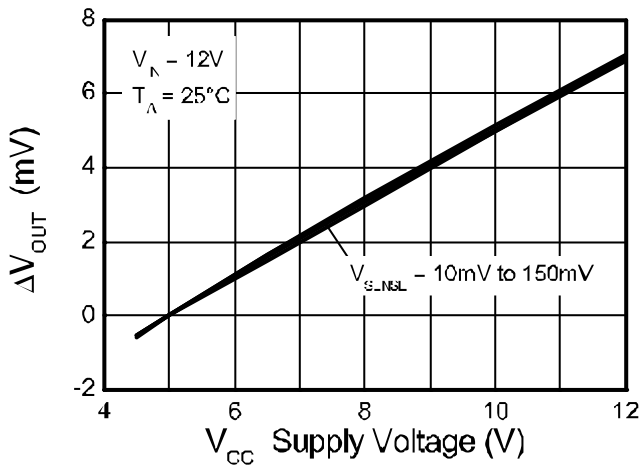

Normalised Output Voltage

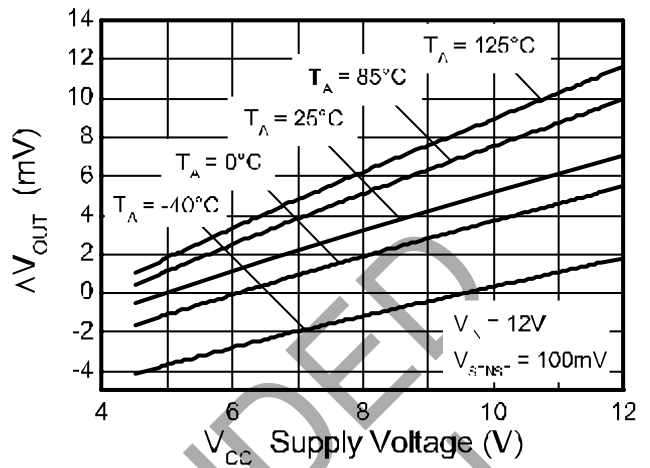

Normalised Output Voltage

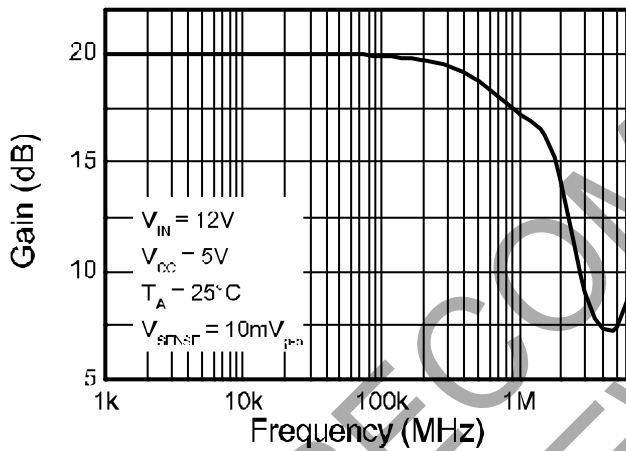

Small Signal Bandwidth

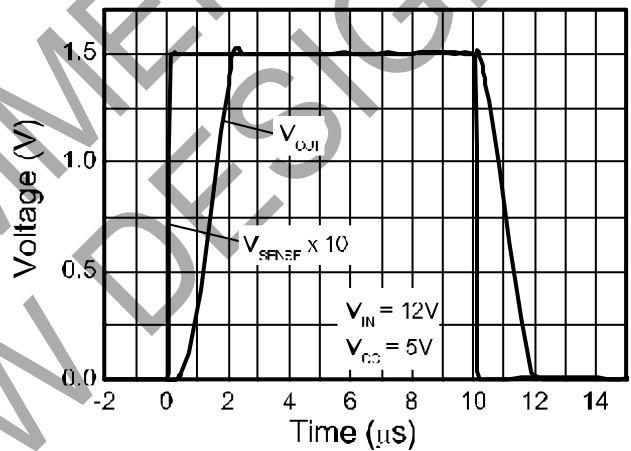

Large Signal Pulse Response

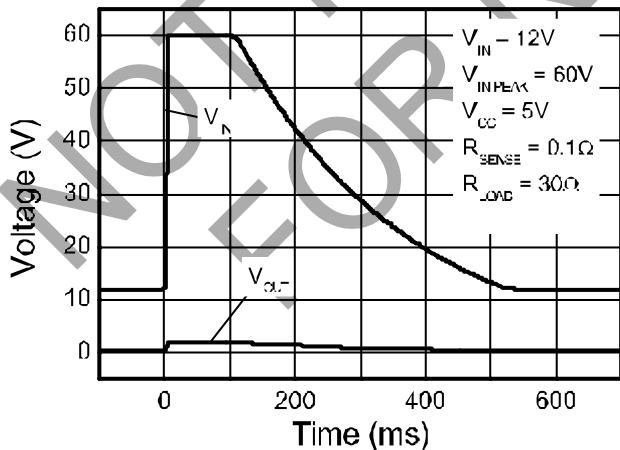

Load Dump Waveform

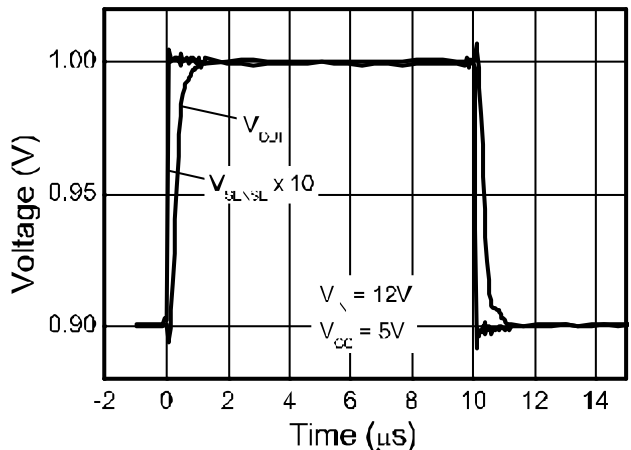

Small Signal Pulse Response

Typical Operating Conditions (continued) (Test conditions: $T_A = +25^\circ\text{C}$, $V_{CC} = 5\text{V}$, $V_{SENSE+} = 12\text{V}$, $V_{SENSE} = 100\text{mV}$)

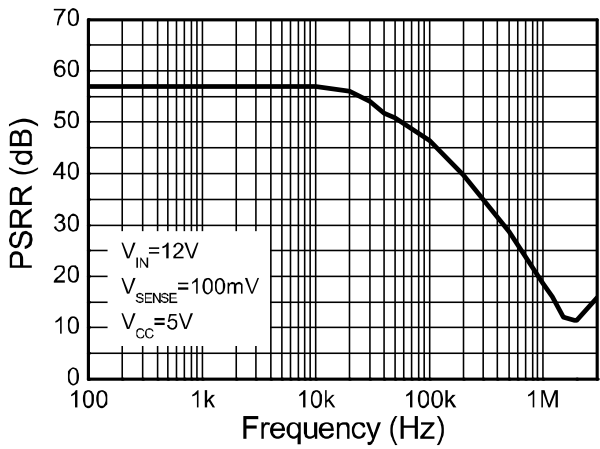

Supply Rejection

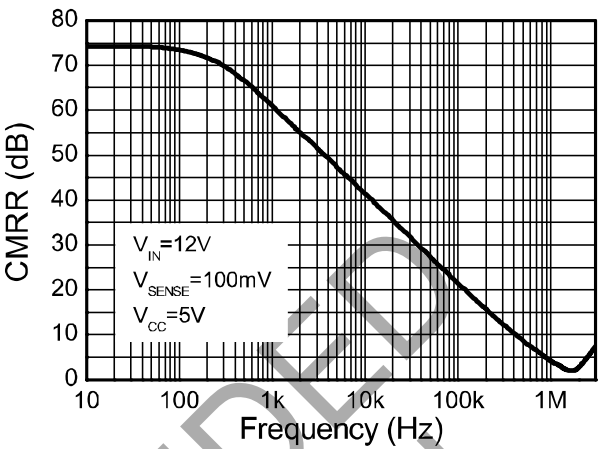

Common Mode Rejection

NOT RECOMMENDED FOR NEW DESIGN

Application Information

The ZXCT1081 has been designed to allow it to operate with 5V supply rails while sensing common mode signals up to 40V. This makes it well suited to a wide range of industrial and power supply monitoring applications that require the interface to 5V systems while sensing much higher voltages.

To allow this its VCC pin can be used independently of SENSE+.

Figure 1 shows the basic configuration of the ZXCT1081.

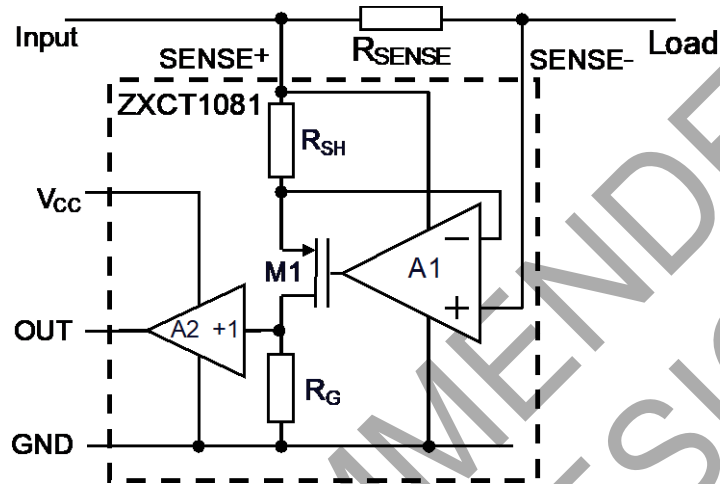

Figure 1. Typical Configuration of ZXCT1081

Load current from the input is drawn through RSENSE developing a voltage VSENSE across the inputs of the ZXCT1081.

The internal amplifier forces VSENSE across internal resistance RSH causing a current to flow through MOSFET M1. This current is then converted to a voltage by RG. A ratio of 10:1 between RG and RSH creates the fixed gain of 10. The output is then buffered by the unity gain buffer.

The gain equation of the ZXCT1081 is:

$$V_{OUT} = I_L R_{SENSE} \frac{R_G}{R_{SH}} \times 1 = \times R_{SENSE} \times 10$$

The maximum recommended differential input voltage, VSENSE, is 150mV; it will however withstand voltages up to 800mV. This can be increased further by the inclusion of a resistor, RLIM, between SENSE- pin and the load; typical value is of the order of 10k.

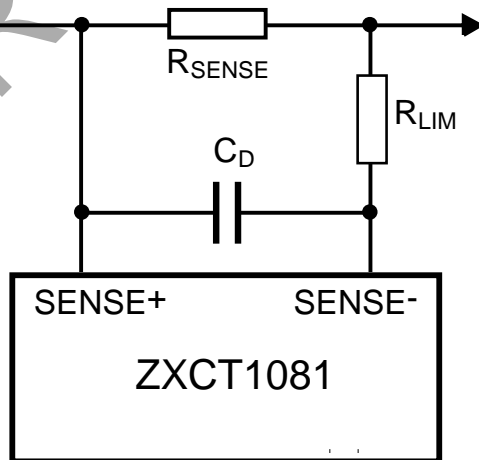

Figure 2. Protection/Error Sources for ZXCT1081

Application Information (continued)

Capacitor C_D provides high frequency transient decoupling when used with R_{LIM} ; typical values are of the order 10pF.

For best performance R_{SENSE} should be connected as close to the SENSE+ (and SENSE-) pins, minimizing any series resistance with R_{SENSE} .

When choosing appropriate values for R_{SENSE} , a compromise must be reached between in-line signal loss (including potential power dissipation effects) and small-signal accuracy.

Higher values for R_{SENSE} gives better accuracy at low load currents by reducing the inaccuracies due to internal offsets. For best operation the ZXCT1081 has been designed to operate with V_{SENSE} of the order of 50mV to 150mV.

Current monitors' basic configuration is that of a unipolar voltage to current to voltage converter powered from a single supply rail. The internal amplifier at the heart of the current monitor may well have a bipolar offset voltage but the output cannot go negative; this results in current monitors saturating at very low sense voltages.

As a result of this phenomenon the ZXCT1081 has been specified to operate in a linear manner over a V_{SENSE} range of 10mV to 150mV range, however it will still be monotonic down to V_{SENSE} of 0V.

It is for this very reason that Diodes Incorporated has specified an input offset voltage ($V_{O(10)}$) at 10mV. The output voltage for any V_{SENSE} voltage from 10mV to 150mV can be calculated as follows:

$$V_{OUT} = (V_{SENSE}) \times G + V_{O(10)}$$

Alternatively, the load current can be expressed as:

$$I_L = \frac{V_{OUT} - V_{O(10)}}{G \times R_{SENSE}}$$

NOT RECOMMENDED FOR NEW DESIGN

Package Outline Dimensions

Please see <http://www.diodes.com/package-outlines.html> for the latest version.

Package Outline – SOT23-5

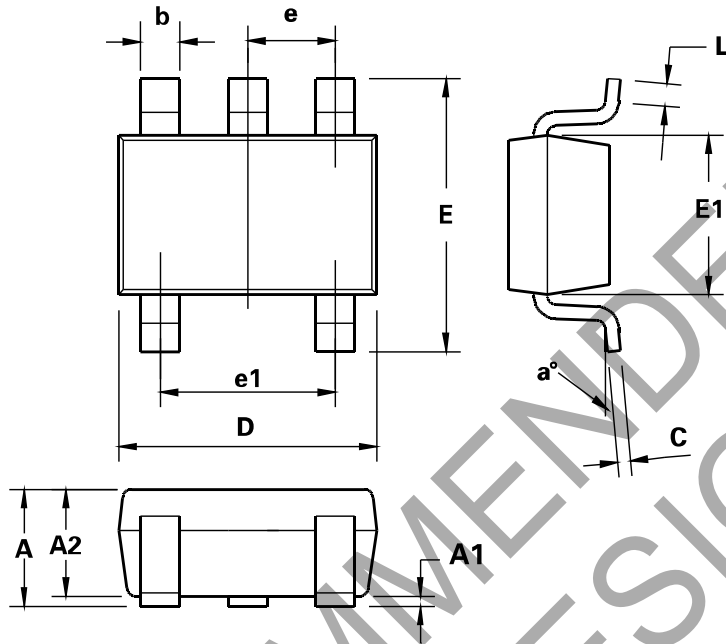

DIM	Millimeters		Inches	
	Min	Max	Min	Max
A	0.90	1.45	0.0354	0.0570
A1	0.00	0.15	0.00	0.0059
A2	0.90	1.3	0.0354	0.0511
b	0.20	0.50	0.0078	0.0196
C	0.09	0.26	0.0035	0.0102
D	2.70	3.10	0.1062	0.1220
E	2.20	3.20	0.0866	0.1181
E1	1.30	1.80	0.0511	0.0708
e	0.95 REF		0.0374 REF	
e1	1.90 REF		0.0748 REF	
L	0.10	0.60	0.0039	0.0236
a°	0	30	0	30

Note: 6. Controlling dimensions are in millimeters. Approximate dimensions are provided in inches.

IMPORTANT NOTICE

1. DIODES INCORPORATED (Diodes) AND ITS SUBSIDIARIES MAKE NO WARRANTY OF ANY KIND, EXPRESS OR IMPLIED, WITH REGARDS TO ANY INFORMATION CONTAINED IN THIS DOCUMENT, INCLUDING, BUT NOT LIMITED TO, THE IMPLIED WARRANTIES OF MERCHANTABILITY, FITNESS FOR A PARTICULAR PURPOSE OR NON-INFRINGEMENT OF THIRD PARTY INTELLECTUAL PROPERTY RIGHTS (AND THEIR EQUIVALENTS UNDER THE LAWS OF ANY JURISDICTION).
2. The Information contained herein is for informational purpose only and is provided only to illustrate the operation of Diodes' products described herein and application examples. Diodes does not assume any liability arising out of the application or use of this document or any product described herein. This document is intended for skilled and technically trained engineering customers and users who design with Diodes' products. Diodes' products may be used to facilitate safety-related applications; however, in all instances customers and users are responsible for (a) selecting the appropriate Diodes products for their applications, (b) evaluating the suitability of Diodes' products for their intended applications, (c) ensuring their applications, which incorporate Diodes' products, comply the applicable legal and regulatory requirements as well as safety and functional-safety related standards, and (d) ensuring they design with appropriate safeguards (including testing, validation, quality control techniques, redundancy, malfunction prevention, and appropriate treatment for aging degradation) to minimize the risks associated with their applications.
3. Diodes assumes no liability for any application-related information, support, assistance or feedback that may be provided by Diodes from time to time. Any customer or user of this document or products described herein will assume all risks and liabilities associated with such use, and will hold Diodes and all companies whose products are represented herein or on Diodes' websites, harmless against all damages and liabilities.
4. Products described herein may be covered by one or more United States, international or foreign patents and pending patent applications. Product names and markings noted herein may also be covered by one or more United States, international or foreign trademarks and trademark applications. Diodes does not convey any license under any of its intellectual property rights or the rights of any third parties (including third parties whose products and services may be described in this document or on Diodes' website) under this document.
5. Diodes' products are provided subject to Diodes' Standard Terms and Conditions of Sale (<https://www.diodes.com/about/company/terms-and-conditions/terms-and-conditions-of-sales/>) or other applicable terms. This document does not alter or expand the applicable warranties provided by Diodes. Diodes does not warrant or accept any liability whatsoever in respect of any products purchased through unauthorized sales channel.
6. Diodes' products and technology may not be used for or incorporated into any products or systems whose manufacture, use or sale is prohibited under any applicable laws and regulations. Should customers or users use Diodes' products in contravention of any applicable laws or regulations, or for any unintended or unauthorized application, customers and users will (a) be solely responsible for any damages, losses or penalties arising in connection therewith or as a result thereof, and (b) indemnify and hold Diodes and its representatives and agents harmless against any and all claims, damages, expenses, and attorney fees arising out of, directly or indirectly, any claim relating to any noncompliance with the applicable laws and regulations, as well as any unintended or unauthorized application.
7. While efforts have been made to ensure the information contained in this document is accurate, complete and current, it may contain technical inaccuracies, omissions and typographical errors. Diodes does not warrant that information contained in this document is error-free and Diodes is under no obligation to update or otherwise correct this information. Notwithstanding the foregoing, Diodes reserves the right to make modifications, enhancements, improvements, corrections or other changes without further notice to this document and any product described herein. This document is written in English but may be translated into multiple languages for reference. Only the English version of this document is the final and determinative format released by Diodes.
8. Any unauthorized copying, modification, distribution, transmission, display or other use of this document (or any portion hereof) is prohibited. Diodes assumes no responsibility for any losses incurred by the customers or users or any third parties arising from any such unauthorized use.
9. This Notice may be periodically updated with the most recent version available at <https://www.diodes.com/about/company/terms-and-conditions/important-notice>

The Diodes logo is a registered trademark of Diodes Incorporated in the United States and other countries.
All other trademarks are the property of their respective owners.
© 2024 Diodes Incorporated. All Rights Reserved.

www.diodes.com