

OBSOLETE - PART DISCONTINUED

Description

The ZXHF5002 provides an integrated IF solution for multiple outputs LNB and switch box applications. The ZXHF5002 includes a 4 x 2 switch with 19dB of positive gain, which can be connected directly to the output of the LNB or switch box eliminating the requirement for cable drive amplifiers.

The ZXHF5002 includes all the control required for voltage- and tone-based systems providing a reliable and highly integrated solution.



Features

- High Linearity 4:2 Switch
- Integrated Cable Drive Amplifiers
- Integrated Switch Control - Tone and Voltage
- WideBandwidth200MHzto2700MHz
- Gain 19dB, Rising Across Band
- High Isolation Typ. >30dB, 200MHz to 2150MHz
- OIP3 >15dBm, 200MHz to 2150MHz
- Reliable Tone Detector With Unwanted Signal Rejection Filter
- Accurate Voltage Detector 14.0V to 15.5V
- Intelligent Low Power Mode
- 3.3V Operation
- Unconditionally Stable
- Pin-Out programmable for Double-Sided Assembly

Applications

- Twin Universal LNBs
- Quad Universal LNBs
- Multiple Output LNBs

Typical Application

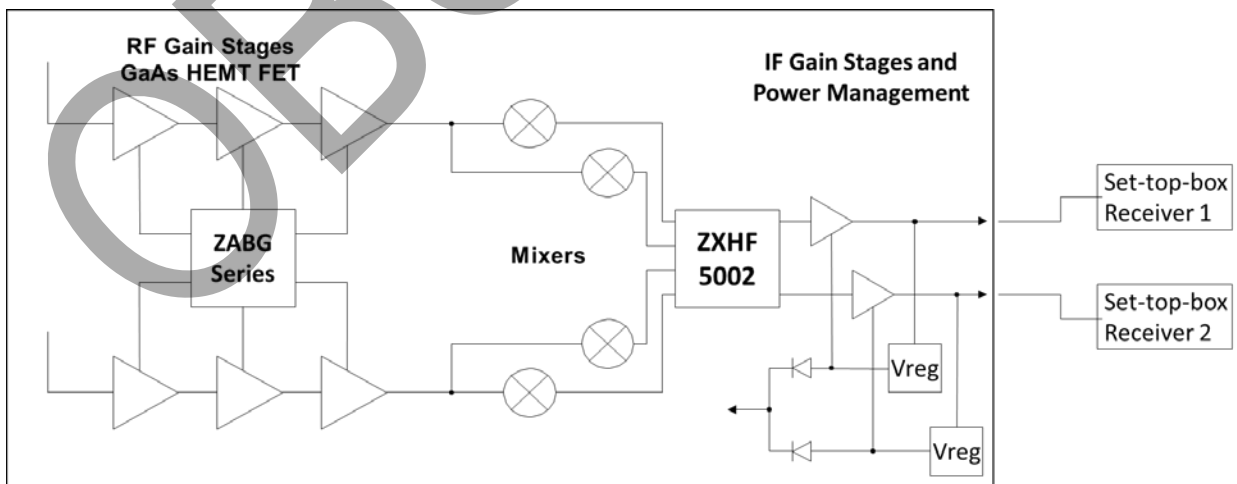

Typical Low Power Twin Universal LNB System

Ordering Information

Device	Package	Reel Size (inches)	Tape Width (mm)	Quantity per Reel	Status
ZXHF5002JB24TC	V-QFN4040-24	13	12	3000	END OF LIFE (EOL)

IMPORTANT NOTICE

DIODES INCORPORATED MAKES NO WARRANTY OF ANY KIND, EXPRESS OR IMPLIED, WITH REGARDS TO THIS DOCUMENT, INCLUDING, BUT NOT LIMITED TO, THE IMPLIED WARRANTIES OF MERCHANTABILITY AND FITNESS FOR A PARTICULAR PURPOSE (AND THEIR EQUIVALENTS UNDER THE LAWS OF ANY JURISDICTION).

Diodes Incorporated and its subsidiaries reserve the right to make modifications, enhancements, improvements, corrections or other changes without further notice to this document and any product described herein. Diodes Incorporated does not assume any liability arising out of the application or use of this document or any product described herein; neither does Diodes Incorporated convey any license under its patent or trademark rights, nor the rights of others. Any Customer or user of this document or products described herein in such applications shall assume all risks of such use and will agree to hold Diodes Incorporated and all the companies whose products are represented on Diodes Incorporated website, harmless against all damages.

Diodes Incorporated does not warrant or accept any liability whatsoever in respect of any products purchased through unauthorized sales channel.

Should Customers purchase or use Diodes Incorporated products for any unintended or unauthorized application, Customers shall indemnify and hold Diodes Incorporated and its representatives harmless against all claims, damages, expenses, and attorney fees arising out of, directly or indirectly, any claim of personal injury or death associated with such unintended or unauthorized application.

Products described herein may be covered by one or more United States, international or foreign patents pending. Product names and markings noted herein may also be covered by one or more United States, international or foreign trademarks.

This document is written in English but may be translated into multiple languages for reference. Only the English version of this document is the final and determinative format released by Diodes Incorporated.

LIFE SUPPORT

Diodes Incorporated products are specifically not authorized for use as critical components in life support devices or systems without the express written approval of the Chief Executive Officer of Diodes Incorporated. As used herein:

A. Life support devices or systems are devices or systems which:

1. are intended to implant into the body, or
2. support or sustain life and whose failure to perform when properly used in accordance with instructions for use provided in the labeling can be reasonably expected to result in significant injury to the user.

B. A critical component is any component in a life support device or system whose failure to perform can be reasonably expected to cause the failure of the life support device or to affect its safety or effectiveness.

Customers represent that they have all necessary expertise in the safety and regulatory ramifications of their life support devices or systems, and acknowledge and agree that they are solely responsible for all legal, regulatory and safety-related requirements concerning their products and any use of Diodes Incorporated products in such safety-critical, life support devices or systems, notwithstanding any devices- or systems-related information or support that may be provided by Diodes Incorporated. Further, Customers must fully indemnify Diodes Incorporated and its representatives against any damages arising out of the use of Diodes Incorporated products in such safety-critical, life support devices or systems.

Copyright © 2019, Diodes Incorporated

www.diodes.com